

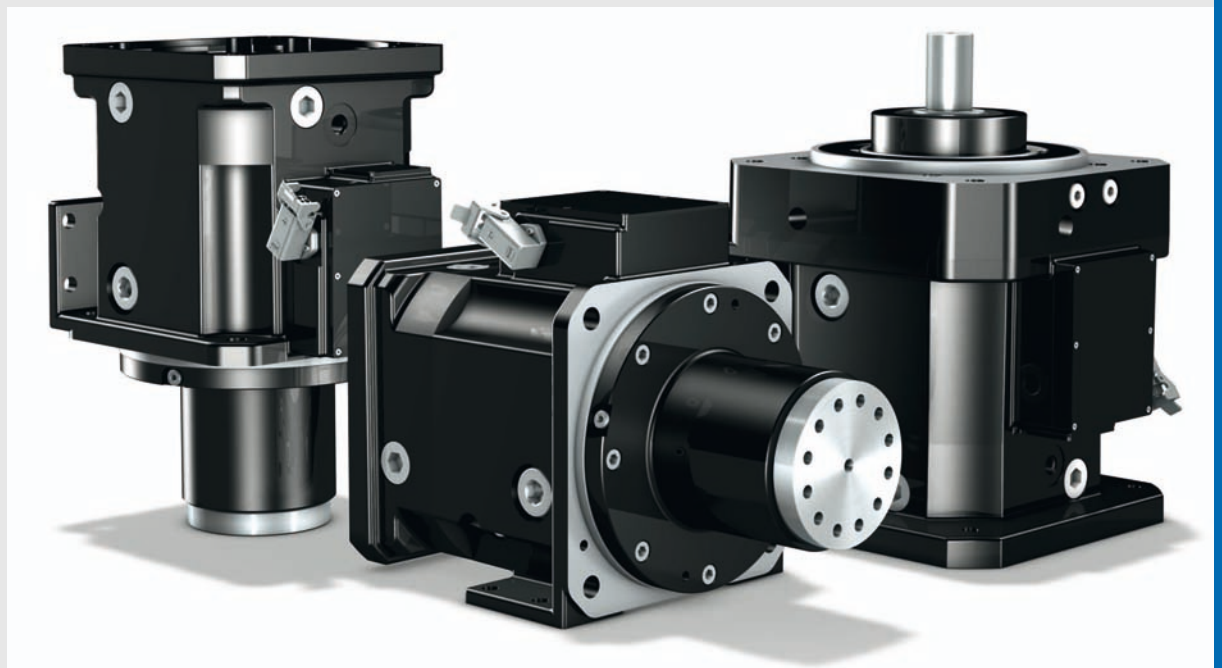

STÖBER

Two-speed Gearbox

PS



POWER²SPEED

Product catalog

Two-speed PS gearbox

STÖBER, decades of innovative drive technology

STÖBER ANTRIEBSTECHNIK has a long drive-related tradition. The family company was founded in 1934 in Pforzheim.

As a service-oriented and worldwide system provider, STÖBER is one of the innovators of digital drive technology.





STOBER IN MOTION
That very special spirit





The top level production strategy gives rise to the highest level of product reliability

For demanding applications, it must be possible to rely on stiffness, smooth running, repeatability and maximum stability.

The well-known product quality is ensured by the highly qualified employees at STOBER who are provided with the latest machines and workstations.



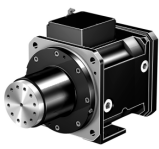
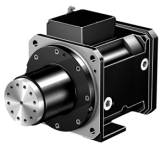

Table of contents

1.1	Overview	9
1.2	Selection tables	10
1.2.1	Maximum speeds	11
1.2.2	Torques	12
1.2.3	Further technical data	12
1.3	Dimensional drawings	13
1.3.1	Connections for lubrication	13
1.3.2	Shaft version G (solid shaft without feather key)	14
1.3.3	Shaft version P (solid shaft with two feather keys)	16
1.3.4	Shaft version F (flange shaft)	18
1.3.5	Shaft design G (solid shaft without feather key), housing design C (cooling flange)	20
1.3.6	Shaft design P (solid shaft with two feather keys), housing design C (cooling flange)	22
1.3.7	Shaft design F (flange shaft), housing design C (cooling flange)	24
1.3.8	Instructions regarding the dimensional drawings	25
1.4	Type designation	26
1.5	Product description	27
1.5.1	General features	27
1.5.2	Ambient conditions	27
1.5.3	Installation	27
1.5.3.1	Installation conditions	27
1.5.3.2	Installation positions	28
1.5.4	Direction of rotation	28
1.5.5	Flange-mounted motor	29
1.5.5.1	Requirements for the installed motor	29
1.5.5.2	Maximum permitted breakdown torque on the gear unit output	29
1.5.6	Lubrication	30
1.5.6.1	Splash lubrication	30
1.5.6.2	Circulation lubrication (optional)	30
1.5.7	Gear switcher	32
1.5.8	Cooling flange (optional)	32
1.6	Projecting	32
1.6.1	Permitted speeds	33
1.6.2	Permissible shaft loads	34
1.6.2.1	Shaft design G/ P (solid shaft)	34
1.6.2.2	Shaft version F (flange shaft)	35

1.7 Service.....	37
1.7.1 Close contact with customers worldwide.....	37
1.7.2 Trademarks.....	37
1.7.3 Sales and delivery conditions.....	37
1.7.4 Imprint.....	38



1.1 Overview

Two-speed gear box PS with loss-optimized direct gear

Technical data

M_{2max}	400 – 2200 Nm
n_{1max}	2500 – 10000 min ⁻¹

Features

Quick change between high speed and high torque	✓
Gear ratio:	
4:1 or 5.5:1 (transmitted gear)	✓
1:1 (direct gear)	✓
Transmitted gear based on a high-precision helical geared planetary gear unit	✓
Loss-optimized direct gear	✓
Neutral gear position (optional)	✓
Flange shaft or solid shaft	✓
Cooling flange on the output (optional)	✓
Splash lubrication or circulation lubrication (optional)	✓
Oil inspection glass or oil level indicator (optional)	✓
Simple and safe motor adaptation	✓

An explanation of the formula symbols can be found on the next page.

Additional documents for the two-speed gear box PS can be found in our documentation center www.stoeber.de

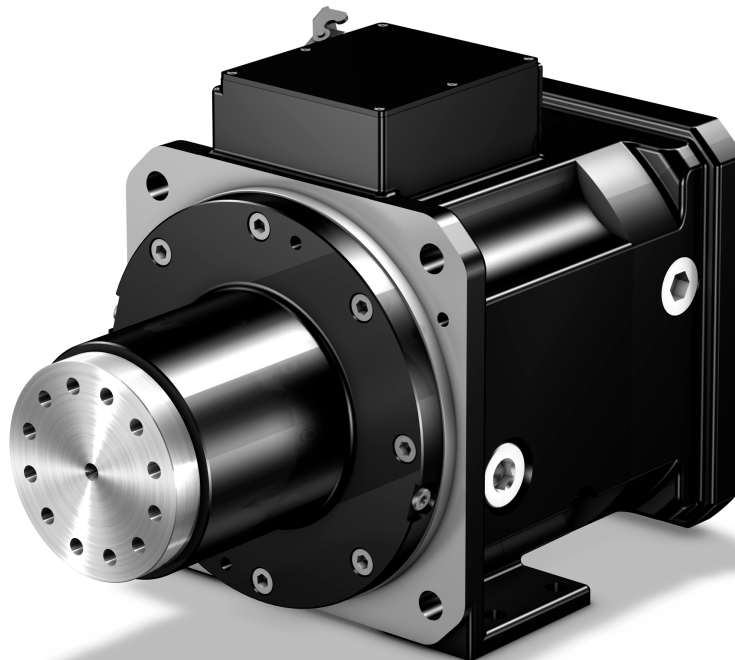

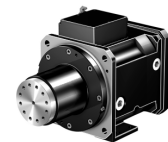

1.2 Selection tables

Note

The technical data below applies to the ambient conditions that are described in Chapter 1.5.2.

Formula symbol	Unit	Explanation
EL	–	Installation position
i	–	Gear ratio
J_1	10^{-4}kgm^2	Mass moment of inertia relative to the input
m	kg	Weight
m_C	kg	Additive weight of the cooling flange
$M_{1\text{max}}$	Nm	Maximum torque on the gear unit input
M_{1N}	Nm	Nominal torque on the gear unit input
$M_{2\text{max}}$	Nm	Maximum torque on the gear unit output
M_{2N}	Nm	Nominal torque on the gear unit output (relative to n_{1N})
$n_{1\text{maxH}}$	rpm	Maximum permitted input speed in horizontal installation positions
$n_{1\text{maxV}}$	rpm	Maximum permitted input speed in vertical installation positions
n_{1N}	rpm	Nominal speed on the gear unit input
$P_{N,GB}$	kW	Nominal output of the gearbox
S1		Continuous operation with constant load (duty cycle 100 %)
S6		Uninterrupted periodic operation (duty cycle 60 % relative to 10 minutes)
v_{sw}	mm/s	Vibration speed (RMS value)
$\Delta\varphi_2$	arcmin	Backlash on the output shaft with the input blocked

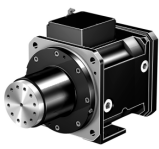

1.2.1 Maximum speeds

The input speeds specified in the following table apply under the conditions described in section 1.6.1.

Maximum speeds with splash lubrication

Typ	i	n_{1maxH}	n_{1maxV}	n_{1maxH}	n_{1maxV}
		EL1, EL3, EL4 S1 [min ⁻¹]	EL5 S1 [min ⁻¹]	EL1, EL3, EL4 S6 [min ⁻¹]	EL5 S6 [min ⁻¹]
PS2501_0040 ME	4.0	3000	2500	4500	3500
–	1.0	5000	4500	6000	5500
PS2501_0055 ME	5.5	3000	2500	4500	3500
–	1.0	5000	4500	6000	5500
PS3001_0040 ME	4.0	3000	2500	4500	3500
–	1.0	5000	4500	6000	5500
PS3001_0055 ME	5.5	3000	2500	4500	3500
–	1.0	5000	4500	6000	5500

Maximum speeds with splash lubrication and cooling flange

Typ	i	n_{1maxH}	n_{1maxV}	n_{1maxH}	n_{1maxV}
		EL1, EL3, EL4 S1 [min ⁻¹]	EL5 S1 [min ⁻¹]	EL1, EL3, EL4 S6 [min ⁻¹]	EL5 S6 [min ⁻¹]
PS2501_0040 ME	4.0	4000	3500	5000	4500
–	1.0	5500	5000	6500	6000
PS2501_0055 ME	5.5	4000	3500	5000	4500
–	1.0	5500	5000	6500	6000
PS3001_0040 ME	4.0	4000	3500	5000	4500
–	1.0	5500	5000	6500	6000
PS3001_0055 ME	5.5	4000	3500	5000	4500
–	1.0	5500	5000	6500	6000

The maximum speeds for the version with cooling flange are in reference to water as the coolant (specification in section 1.5.8). If another coolant is used, you will have to determine the maximum speeds again. For detailed instructions please consult the manufacturer of your cooling system.

Maximum speeds with circulation lubrication system

Typ	i	n_{1maxH}	n_{1maxV}	n_{1maxH}	n_{1maxV}
		EL1, EL3, EL4 S1 [min ⁻¹]	EL5, EL6 S1 [min ⁻¹]	EL1, EL3, EL4 S6 [min ⁻¹]	EL5, EL6 S6 [min ⁻¹]
PS2501_0040	4.0	6500	6500	7000	7000
–	1.0	8000	8000	10000	10000
PS2501_0055	5.5	6500	6500	7000	7000
–	1.0	8000	8000	10000	10000
PS3001_0040	4.0	6500	6500	7000	7000
–	1.0	8000	8000	10000	10000
PS3001_0055	5.5	6500	6500	7000	7000
–	1.0	8000	8000	10000	10000

The specification of the circulation lubrication system can be found in section 1.5.6.2.

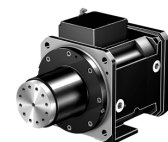

1.2.2 Torques

Typ	i	P _{N,GB} [kW]	M _{1N} [Nm]	M _{2N} [Nm]	M _{1max} [Nm]	M _{2max} [Nm]
PS2501_0040 ME	4.0	47	300	1200	400	1600
–	1.0	47	300	300	400	400
PS2501_0055 ME	5.5	47	250	1375	400	2200
–	1.0	47	250	250	400	400
PS3001_0040 ME	4.0	47	300	1200	400	1600
–	1.0	47	300	300	400	400
PS3001_0055 ME	5.5	47	250	1375	400	2200
–	1.0	47	250	250	400	400

The nominal torque for the output M_{2N} is relative to the input speed n_{1N} = 1500 rpm.

1.2.3 Further technical data

Shaft version G (solid shaft without feather key)

Typ	J ₁ 10 ⁻⁴ [kgm ²]	m [kg]	m _C [kg]	Δφ ₂ [arcmin]	v _{sw} [mm/s]
PS25	82	86	15	30/20	1
PS30	82	95	24	30/20	1

Shaft version P (solid shaft with two feather keys)

Typ	J ₁ 10 ⁻⁴ [kgm ²]	m [kg]	m _C [kg]	Δφ ₂ [arcmin]	v _{sw} [mm/s]
PS25	85	86	15	30/20	1
PS30	85	95	24	30/20	1

Shaft version F (flange shaft)

Typ	J ₁ 10 ⁻⁴ [kgm ²]	m [kg]	m _C [kg]	Δφ ₂ [arcmin]	v _{sw} [mm/s]
PS25	120	86	15	30/20	1
PS30	120	95	24	30/20	1

Instructions

- The mass moment of inertia J₁ applies to both the transmitted and the direct gear for the relevant shaft version.
- The vibration speed v_{sw} was determined in accordance with DIN ISO 10816 under the following test conditions: n_{1m*} = 5000 rpm, load-free, soft installation, bearing version with angular ball bearing.

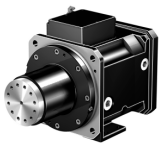

1.3 Dimensional drawings

1.3.1 Connections for lubrication

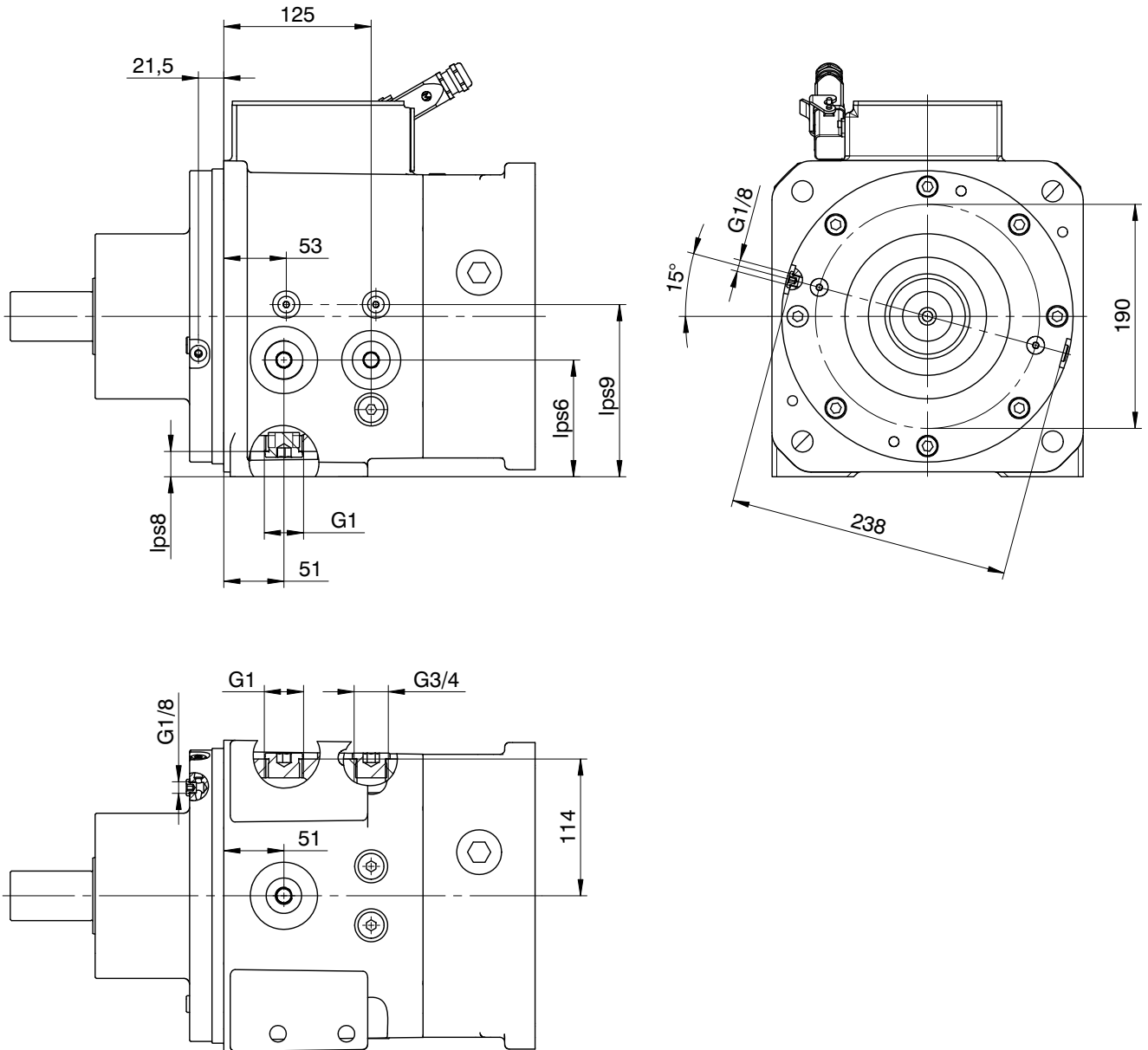

	lps6	lps8	lps9
PS25	99	21.5	146
PS30	127	49.5	174

Instructions	Page
General instructions regarding the dimensional drawings	25

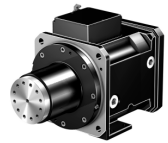

Two-speed PS gearbox



1.3.2 Shaft version G (solid shaft without feather key)

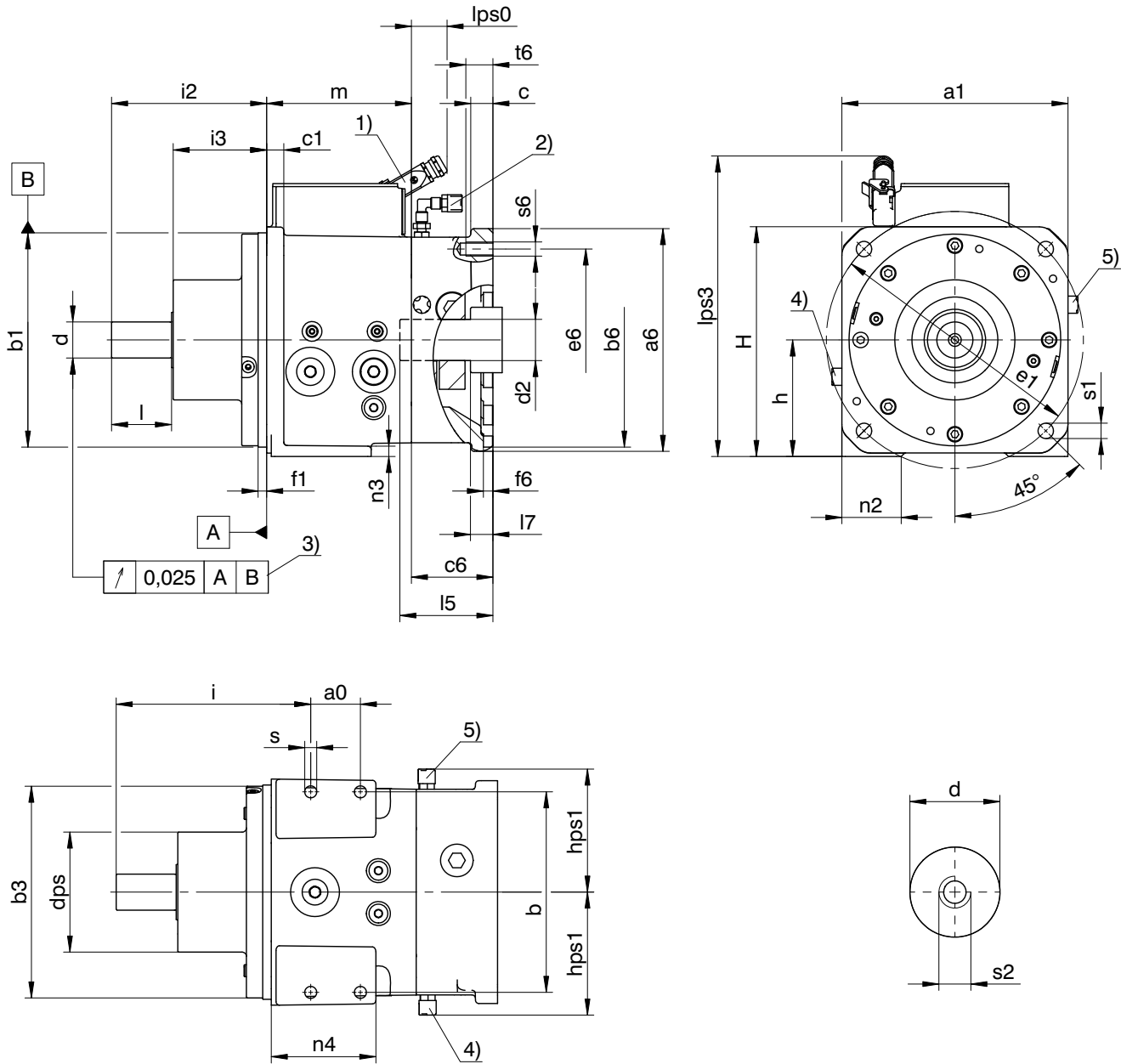

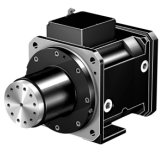

Bearing design S (short bearing distance)

	∅d	a0	□a1	b	∅b1	∅b3	c1	∅dps	∅e1	f1	h	H	i	i2	i3	l	lps0	lps3	m	n2	n3	n4	s	∅s1	s2
PS25	42 _{k6}	58	264	234	250 _{h6}	247	20	140	300	10	136	268	227	181	109	70	41	350	169	69	12.0	122	14	18	M10
PS30	42 _{k6}	58	320	290	250 _{h6}	247	20	140	350	10	164	324	227	181	109	70	41	380	169	62	17.5	122	14	18	M10

Bearing design M (medium bearing distance)

	∅d	a0	□a1	b	∅b1	∅b3	c1	∅dps	∅e1	f1	h	H	i	i2	i3	l	lps0	lps3	m	n2	n3	n4	s	∅s1	s2
PS25	42 _{k6}	58	264	234	250 _{h6}	247	20	140	300	10	136	268	267	221	149	70	41	350	169	69	12.0	122	14	18	M10
PS25	55 _{m6}	58	264	234	250 _{h6}	247	20	140	300	10	136	268	267	261	149	110	41	350	169	69	12.0	122	14	18	M12
PS30	42 _{k6}	58	320	290	250 _{h6}	247	20	140	350	10	164	324	267	221	149	70	41	380	169	62	17.5	122	14	18	M10
PS30	55 _{m6}	58	320	290	250 _{h6}	247	20	140	350	10	164	324	267	261	149	110	41	380	169	62	17.5	122	14	18	M12

Motor connection dimensions

	∅b6	∅d2	∅e6	I _{5max}	□a6	c	c6	f6	hps1	l7	∅s6	t6
PS25	230 ^{H7}	42/48/55	265	112	250	24.5	95	11	139	31	M12	32.0
PS30	230 ^{H7}	42/48/55	265	112	250	24.5	95	11	139	31	M12	32.0
PS25	250 ^{H7}	42/48/55	300	112	260	24.5	95	11	144	31	M16	32.0
PS30	250 ^{H7}	42/48/55	300	112	260	24.5	95	11	144	31	M16	32.0
PS25 ⁷⁾	300 ^{H7}	42/48/55	350	112	314	26.3	95	11	171	31	M16	26.3
PS30 ⁷⁾	300 ^{H7}	42/48/55	350	112	314	26.3	95	11	171	31	M16	26.3
PS25 ⁷⁾	300 ^{H7}	60	350	142	314	26.3	125	11	171	61	M16	26.3
PS30 ⁷⁾	300 ^{H7}	60	350	142	314	26.3	125	11	171	61	M16	26.3

Instructions	Page
General instructions regarding the dimensional drawings	25
1) Mating plug for the electrical connection of the gear switcher (optional). For designs with the dimensions a6 ≤ 250 mm, you can also mount the housing of the connector in the horizontal position if this is appropriate for the cable guide.	–
2) Venting valve, only for circulation lubrication and installation position EL5	–
3) Only applies for bearing design S	–
4) Venting valve, only for circulation lubrication and installation position EL4	–
5) Venting valve, only for circulation lubrication and installation position EL3	–
6) –	–
7) Option	–

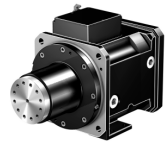

1.3.3 Shaft version P (solid shaft with two feather keys)

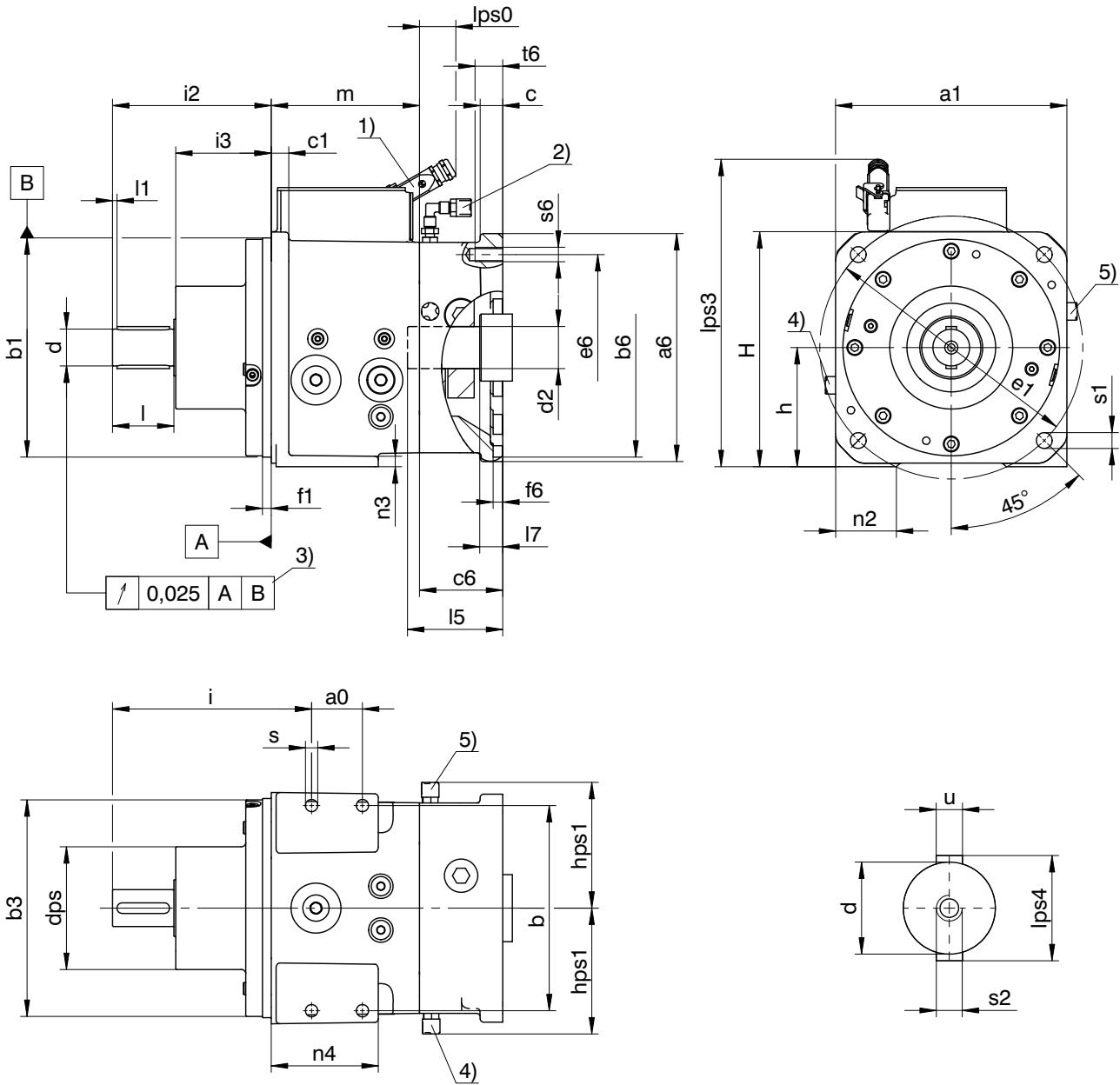

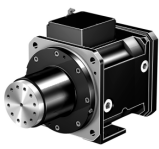

Bearing design S (short bearing distance)

	∅d	a0	□a1	b	∅b1	∅b3	c1	∅dps	∅e1	f1	h	H	i	i2	i3	l	l1	lps0	lps3	lps4	m	n2	n3	n4	s	∅s1	s2	u
PS25	42 _{k6}	58	264	234	250 _{h6}	247	20	140	300	10	136	268	227	181	109	70	3	41	350	48	169	69	12.0	122	14	18	M10	A12x8x63
PS30	42 _{k6}	58	320	290	250 _{h6}	247	20	140	350	10	164	324	227	181	109	70	3	41	380	48	169	62	17.5	122	14	18	M10	A12x8x63

Bearing design M (medium bearing distance)

	∅d	a0	□a1	b	∅b1	∅b3	c1	∅dps	∅e1	f1	h	H	i	i2	i3	l	l1	lps0	lps3	lps4	m	n2	n3	n4	s	∅s1	s2	u
PS25	42 _{k6}	58	264	234	250 _{h6}	247	20	140	300	10	136	268	267	221	149	70	3	41	350	48	169	69	12.0	122	14	18	M10	A12x8x63
PS25	55 _{m6}	58	264	234	250 _{h6}	247	20	140	300	10	136	268	267	261	149	110	10	41	350	63	169	69	12.0	122	14	18	M12	A16x10x90
PS30	42 _{k6}	58	320	290	250 _{h6}	247	20	140	350	10	164	324	267	221	149	70	3	41	380	48	169	62	17.5	122	14	18	M10	A12x8x63
PS30	55 _{m6}	58	320	290	250 _{h6}	247	20	140	350	10	164	324	267	261	149	110	10	41	380	63	169	62	17.5	122	14	18	M12	A16x10x90

Motor connection dimensions

	∅b6	∅d2	∅e6	I5 _{max}	□a6	c	c6	f6	hps1	l7	∅s6	t6
PS25	230 ^{H7}	42/48/55	265	112	250	24.5	95	11	139	31	M12	32.0
PS30	230 ^{H7}	42/48/55	265	112	250	24.5	95	11	139	31	M12	32.0
PS25	250 ^{H7}	42/48/55	300	112	260	24.5	95	11	144	31	M16	32.0
PS30	250 ^{H7}	42/48/55	300	112	260	24.5	95	11	144	31	M16	32.0
PS25 ⁷⁾	300 ^{H7}	42/48/55	350	112	314	26.3	95	11	171	31	M16	26.3
PS30 ⁷⁾	300 ^{H7}	42/48/55	350	112	314	26.3	95	11	171	31	M16	26.3
PS25 ⁷⁾	300 ^{H7}	60	350	142	314	26.3	125	11	171	61	M16	26.3
PS30 ⁷⁾	300 ^{H7}	60	350	142	314	26.3	125	11	171	61	M16	26.3

Instructions	Page
General instructions regarding the dimensional drawings	25
1) Mating plug for the electrical connection of the gear switcher (optional). For designs with the dimensions a6 ≤ 250 mm, you can also mount the housing of the connector in the horizontal position if this is appropriate for the cable guide.	–
2) Venting valve, only for circulation lubrication and installation position EL5	–
3) Only applies for bearing design S	–
4) Venting valve, only for circulation lubrication and installation position EL4	–
5) Venting valve, only for circulation lubrication and installation position EL3	–
6) –	–
7) Option	–

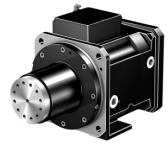

1.3.4 Shaft version F (flange shaft)

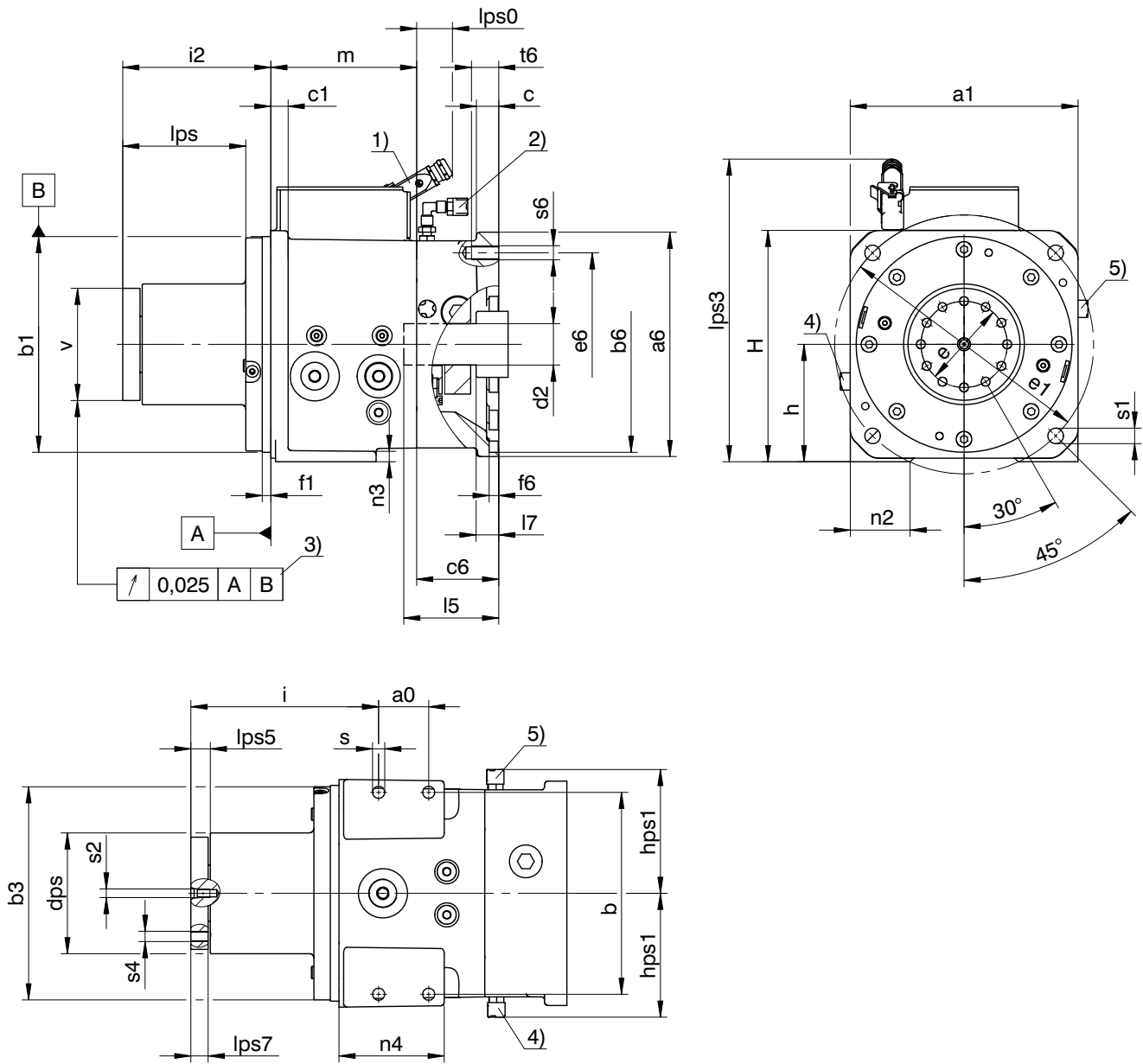

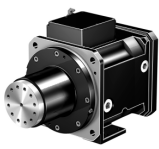

Bearing design M (medium bearing distance)

	∅v	a0	□a1	b	∅b1	∅b3	c1	∅dps	∅e	∅e1	f1	h	H	i	i2	lps	lps0	lps3	lps5	lps7	m	n2	n3	n4	s	∅s1	s2	s4
PS25	118 _{k6}	58	264	234	250 _{h6}	247	20	116	100	300	10	136	268	217.5	171.5	142.5	41	350	22	20	169	69	12.0	122	14	18	M10	M12
PS25	118 _{k6}	58	264	234	250 _{h6}	247	20	140	100	300	10	136	268	217.5	171.5	142.5	41	350	22	20	169	69	12.0	122	14	18	M10	M12
PS25	130 _{k6}	58	264	234	250 _{h6}	247	20	140	100	300	10	136	268	217.5	171.5	142.5	41	350	22	20	169	69	12.0	122	14	18	M10	M12
PS30	118 _{k6}	58	320	290	250 _{h6}	247	20	116	100	350	10	164	324	217.5	171.5	142.5	41	380	22	20	169	62	17.5	122	14	18	M10	M12
PS30	118 _{k6}	58	320	290	250 _{h6}	247	20	140	100	350	10	164	324	217.5	171.5	142.5	41	380	22	20	169	62	17.5	122	14	18	M10	M12
PS30	130 _{k6}	58	320	290	250 _{h6}	247	20	140	100	350	10	164	324	217.5	171.5	142.5	41	380	22	20	169	62	17.5	122	14	18	M10	M12

Bearing design L (long bearing distance)

	∅v	a0	□a1	b	∅b1	∅b3	c1	∅dps	∅e	∅e1	f1	h	H	i	i2	lps	lps0	lps3	lps5	lps7	m	n2	n3	n4	s	∅s1	s2	s4
PS25	130 _{k6}	58	264	234	250 _{h6}	247	20	140	100	300	10	136	268	282	236	207	41	350	22	20	169	69	12.0	122	14	18	M10	M12
PS30	130 _{k6}	58	320	290	250 _{h6}	247	20	140	100	350	10	164	324	282	236	207	41	380	22	20	169	62	17.5	122	14	18	M10	M12

Motor connection dimensions

	∅b6	∅d2	∅e6	I _{5max}	□a6	c	c6	f6	hps1	l7	∅s6	t6
PS25	230 ^{H7}	42/48/55	265	112	250	24.5	95	11	139	31	M12	32.0
PS30	230 ^{H7}	42/48/55	265	112	250	24.5	95	11	139	31	M12	32.0
PS25	250 ^{H7}	42/48/55	300	112	260	24.5	95	11	144	31	M16	32.0
PS30	250 ^{H7}	42/48/55	300	112	260	24.5	95	11	144	31	M16	32.0
PS25 ⁷⁾	300 ^{H7}	42/48/55	350	112	314	26.3	95	11	171	31	M16	26.3
PS30 ⁷⁾	300 ^{H7}	42/48/55	350	112	314	26.3	95	11	171	31	M16	26.3
PS25 ⁷⁾	300 ^{H7}	60	350	142	314	26.3	125	11	171	61	M16	26.3
PS30 ⁷⁾	300 ^{H7}	60	350	142	314	26.3	125	11	171	61	M16	26.3

Instructions	Page
General instructions regarding the dimensional drawings	25
1) Mating plug for the electrical connection of the gear switcher (optional). For designs with the dimensions a6 ≤ 250 mm, you can also mount the housing of the connector in the horizontal position if this is appropriate for the cable guide.	—
2) Venting valve, only for circulation lubrication and installation position EL5	—
3) Only applies for bearing design S	—
4) Venting valve, only for circulation lubrication and installation position EL4	—
5) Venting valve, only for circulation lubrication and installation position EL3	—
6) —	—
7) Option	—

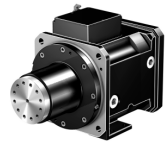

1.3.5 Shaft design G (solid shaft without feather key), housing design C (cooling flange)

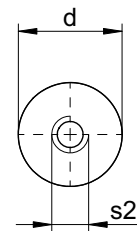
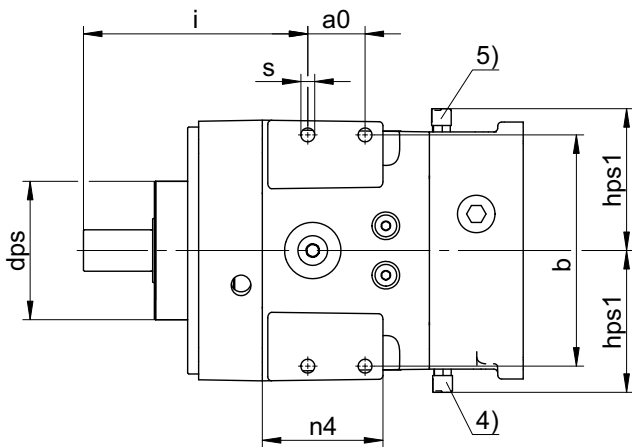
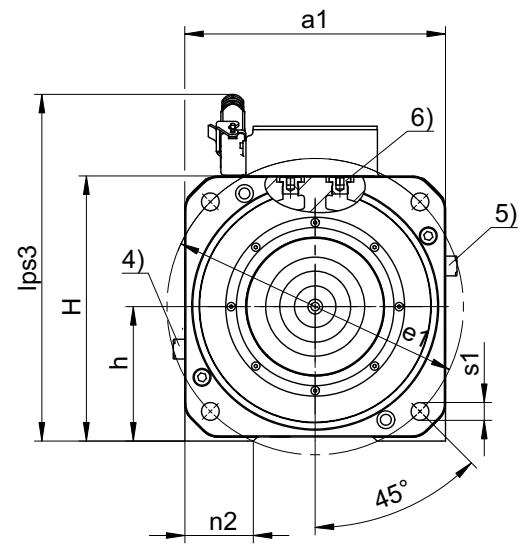
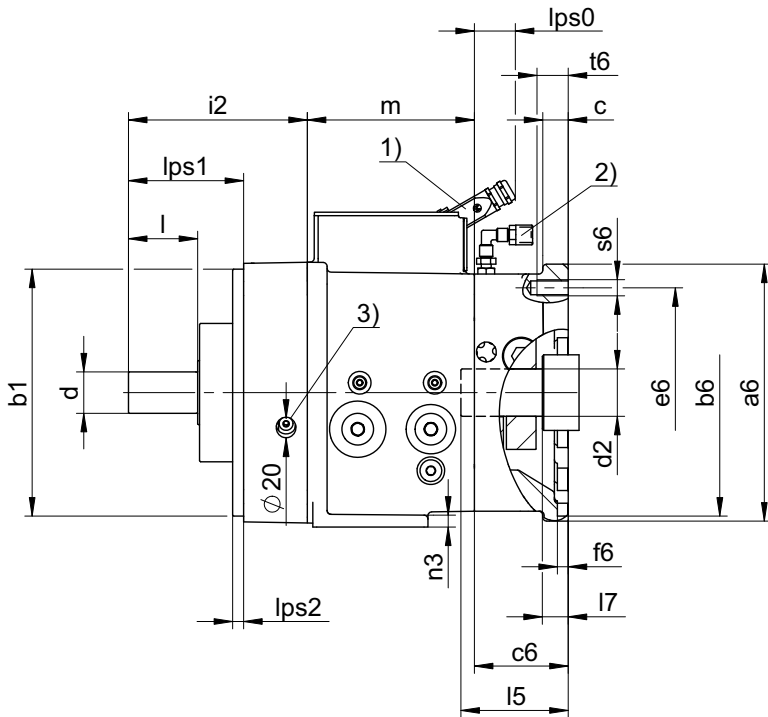
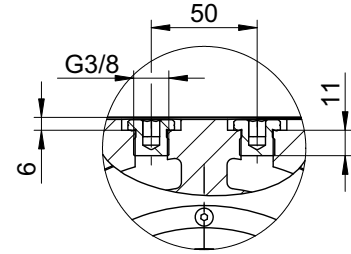

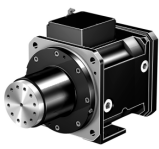

Bearing design S (short bearing distance)

	∅d	a0	□a1	b	∅b1	∅dps	∅e1	h	H	i	i2	l	lps0	lps1	lps2	lps3	m	n2	n3	n4	s	∅s1	s2
PS25	42 _{k6}	58	264	234	250 _{h6}	140	300	136	268	227	181	70	41	116.5	11	350	169	69	12.0	122	14	18	M10
PS30	42 _{k6}	58	320	290	250 _{h6}	140	350	164	324	227	181	70	41	116.5	11	380	169	62	17.5	122	14	18	M10

Bearing design M (medium bearing distance)

	∅d	a0	□a1	b	∅b1	∅dps	∅e1	h	H	i	i2	l	lps0	lps1	lps2	lps3	m	n2	n3	n4	s	∅s1	s2
PS25	42 _{k6}	58	264	234	250 _{h6}	140	300	136	268	267	221	70	41	156.5	11	350	169	69	12.0	122	14	18	M10
PS25	55 _{k6}	58	264	234	250 _{h6}	140	300	136	268	267	261	110	41	196.5	11	350	169	69	12.0	122	14	18	M12
PS30	42 _{k6}	58	320	290	250 _{h6}	140	350	164	324	267	221	70	41	156.5	11	380	169	62	17.5	122	14	18	M10
PS30	55 _{k6}	58	320	290	250 _{h6}	140	350	164	324	267	261	110	41	196.5	11	380	169	62	17.5	122	14	18	M12

Motor connection dimensions

	∅b6	∅d2	∅e6	l5 _{max}	□a6	c	c6	f6	hps1	l7	∅s6	t6
PS25	230 ^{H7}	42/48/55	265	112	250	24.5	95	11	139	31	M12	32.0
PS30	230 ^{H7}	42/48/55	265	112	250	24.5	95	11	139	31	M12	32.0
PS25	250 ^{H7}	42/48/55	300	112	260	24.5	95	11	144	31	M16	32.0
PS30	250 ^{H7}	42/48/55	300	112	260	24.5	95	11	144	31	M16	32.0
PS25 ⁷⁾	300 ^{H7}	42/48/55	350	112	314	26.3	95	11	171	31	M16	26.3
PS30 ⁷⁾	300 ^{H7}	42/48/55	350	112	314	26.3	95	11	171	31	M16	26.3
PS25 ⁷⁾	300 ^{H7}	60	350	142	314	26.3	125	11	171	61	M16	26.3
PS30 ⁷⁾	300 ^{H7}	60	350	142	314	26.3	125	11	171	61	M16	26.3

Instructions	Page
General instructions regarding the dimensional drawings	25
1) Mating plug for the electrical connection of the gear switcher (optional). For designs with the dimensions a6 ≤ 250 mm, you can also mount the housing of the connector in the horizontal position if this is appropriate for the cable guide.	—
2) Venting valve, only for circulation lubrication and installation position EL5	—
3) Access bore hole (on each side of the cooling flange) for lubrication connections E/H	—
4) Venting valve, only for circulation lubrication and installation position EL4	—
5) Venting valve, only for circulation lubrication and installation position EL3	—
6) The cooling flange can be rotated in increments of 90 °	—
7) Option	—

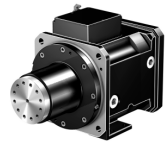

1.3.6 Shaft design P (solid shaft with two feather keys), housing design C (cooling flange)

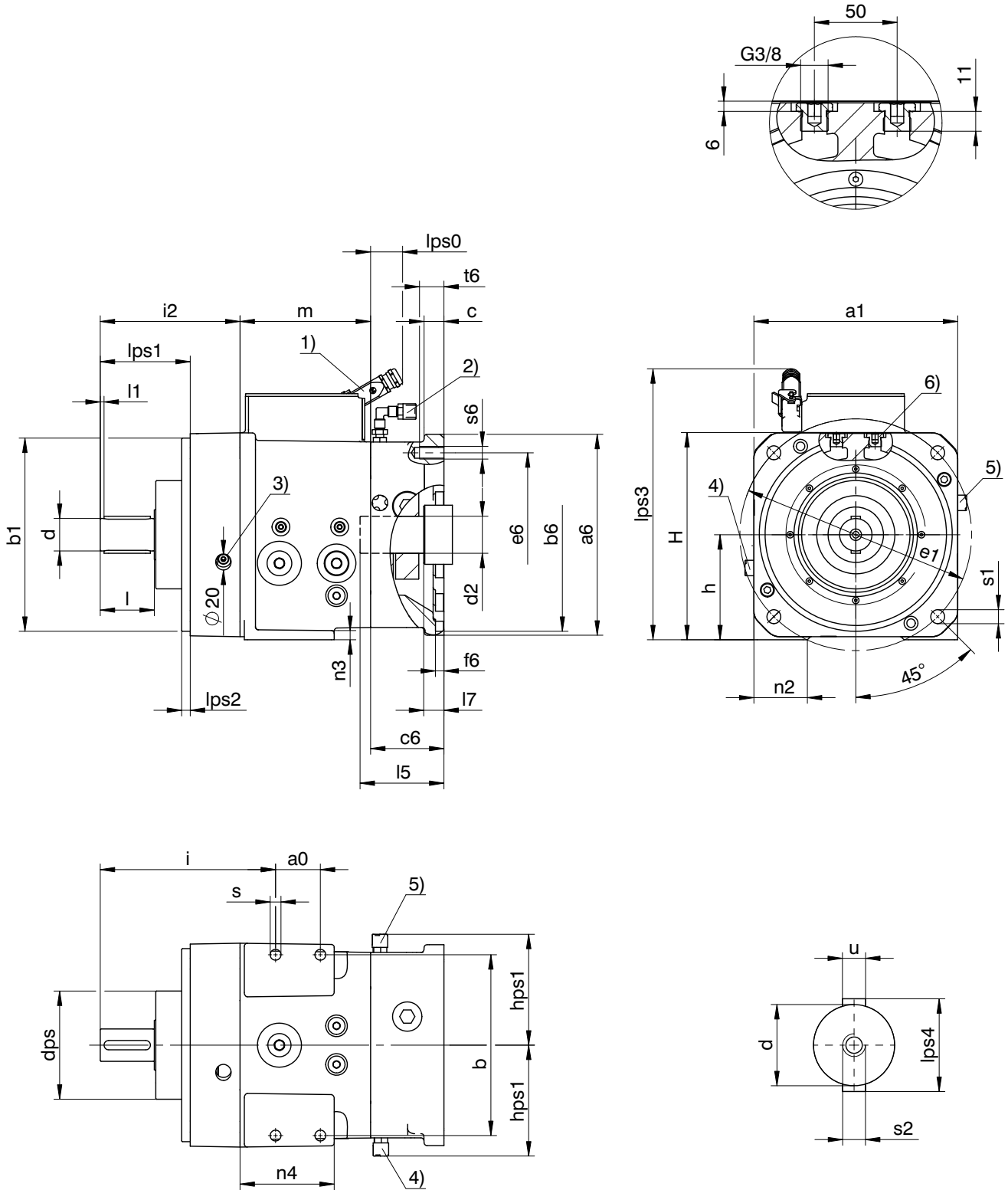

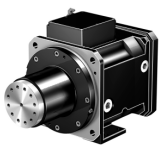

Bearing design S (short bearing distance)

	∅d	a0	□a1	b	∅b1	∅dps	∅e1	h	H	i	i2	l	l1	lps0	lps1	lps2	lps3	lps4	m	n2	n3	n4	s	∅s1	s2	u
PS25	42 _{k6}	58	264	234	250 _{h6}	140	300	136	268	227	181	70	3	41	116.5	11	350	48	169	69	12.0	122	14	18	M10	A12x8x63
PS30	42 _{k6}	58	320	290	250 _{h6}	140	350	164	324	227	181	70	3	41	116.5	11	380	48	169	62	17.5	122	14	18	M10	A12x8x63

Bearing design M (medium bearing distance)

	∅d	a0	□a1	b	∅b1	∅dps	∅e1	h	H	i	i2	l	l1	lps0	lps1	lps2	lps3	lps4	m	n2	n3	n4	s	∅s1	s2	u
PS25	42 _{k6}	58	264	234	250 _{h6}	140	300	136	268	267	221	70	3	41	156.5	11	350	48	169	69	12.0	122	14	18	M10	A12x8x63
PS25	55 _{k6}	58	264	234	250 _{h6}	140	300	136	268	267	261	110	10	41	196.5	11	350	63	169	69	12.0	122	14	18	M12	A16x10x90
PS30	42 _{k6}	58	320	290	250 _{h6}	140	350	164	324	267	221	70	3	41	156.5	11	380	48	169	62	17.5	122	14	18	M10	A12x8x63
PS30	55 _{k6}	58	320	290	250 _{h6}	140	350	164	324	267	261	110	10	41	196.5	11	380	63	169	62	17.5	122	14	18	M12	A16x10x90

Motor connection dimensions

	∅b6	∅d2	∅e6	l5 _{max}	□a6	c	c6	f6	hps1	l7	∅s6	t6
PS25	230 ^{H7}	42/48/55	265	112	250	24.5	95	11	139	31	M12	32.0
PS30	230 ^{H7}	42/48/55	265	112	250	24.5	95	11	139	31	M12	32.0
PS25	250 ^{H7}	42/48/55	300	112	260	24.5	95	11	144	31	M16	32.0
PS30	250 ^{H7}	42/48/55	300	112	260	24.5	95	11	144	31	M16	32.0
PS25 ⁷⁾	300 ^{H7}	42/48/55	350	112	314	26.3	95	11	171	31	M16	26.3
PS30 ⁷⁾	300 ^{H7}	42/48/55	350	112	314	26.3	95	11	171	31	M16	26.3
PS25 ⁷⁾	300 ^{H7}	60	350	142	314	26.3	125	11	171	61	M16	26.3
PS30 ⁷⁾	300 ^{H7}	60	350	142	314	26.3	125	11	171	61	M16	26.3

Instructions	Page
General instructions regarding the dimensional drawings	25
1) Mating plug for the electrical connection of the gear switcher (optional). For designs with the dimensions a6 ≤ 250 mm, you can also mount the housing of the connector in the horizontal position if this is appropriate for the cable guide.	—
2) Venting valve, only for circulation lubrication and installation position EL5	—
3) Access bore hole (on each side of the cooling flange) for lubrication connections E/H	—
4) Venting valve, only for circulation lubrication and installation position EL4	—
5) Venting valve, only for circulation lubrication and installation position EL3	—
6) The cooling flange can be rotated in increments of 90 °	—
7) Option	—

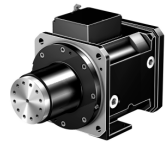

1.3.7 Shaft design F (flange shaft), housing design C (cooling flange)

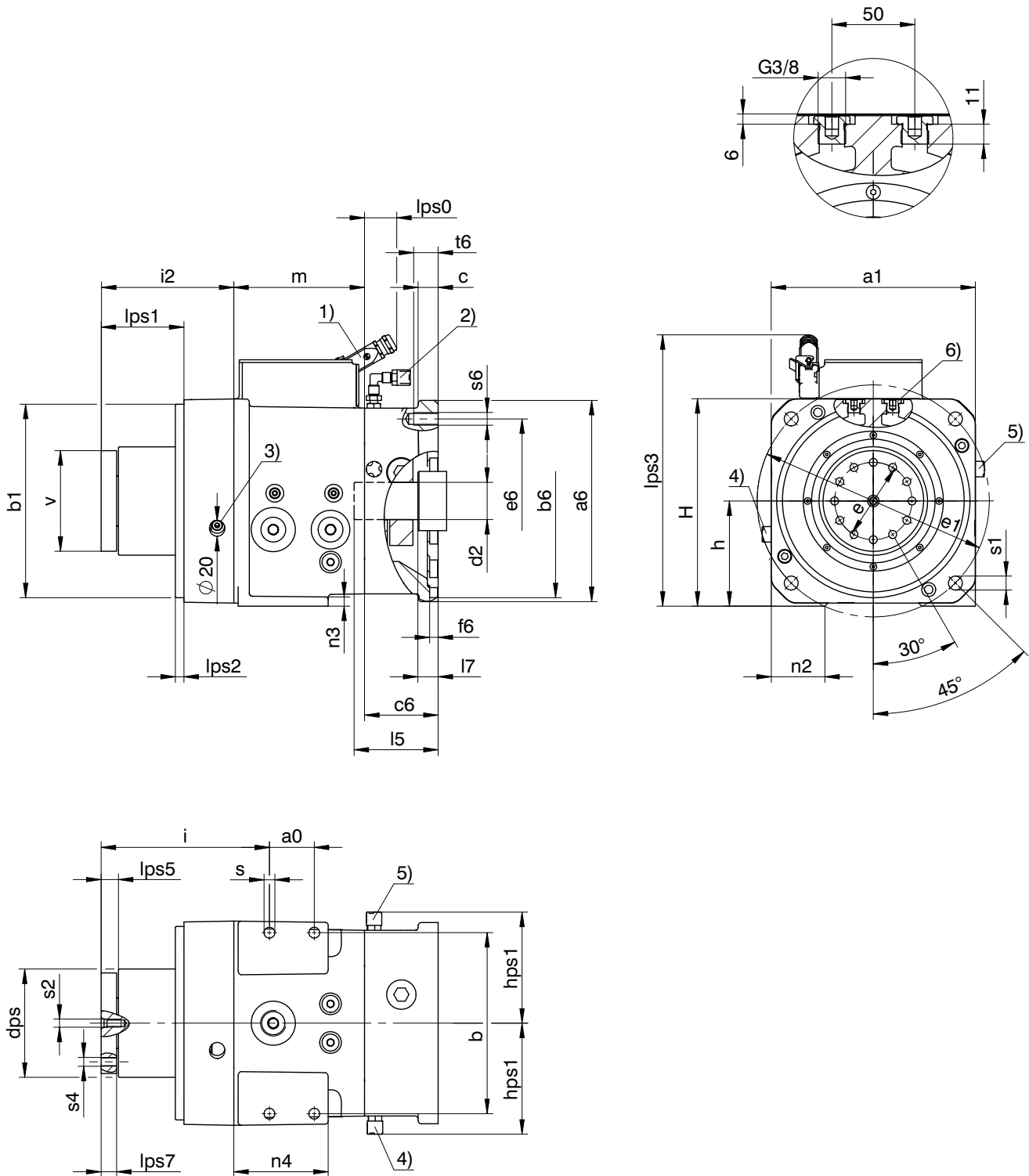

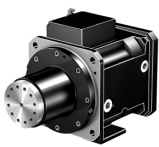

Bearing design M (medium bearing distance)

	∅v	a0	∏a1	b	∅b1	∅dps	∅e	∅e1	h	H	i	i2	lps0	lps1	lps3	lps5	lps7	m	n2	n3	n4	s	∅s1	s2	s4
PS25	118 _{k6}	58	264	234	250 _{h6}	116	100	300	136	268	217.5	171.5	41	107	350	22	20	169	69	12.0	122	14	18	M10	M12
PS25	118 _{k6}	58	264	234	250 _{h6}	140	100	300	136	268	217.5	171.5	41	107	350	22	20	169	69	12.0	122	14	18	M10	M12
PS25	130 _{k6}	58	264	234	250 _{h6}	140	100	300	136	268	217.5	171.5	41	107	350	22	20	169	69	12.0	122	14	18	M10	M12
PS30	118 _{k6}	58	320	290	250 _{h6}	116	100	350	164	324	217.5	171.5	41	107	380	22	20	169	62	17.5	122	14	18	M10	M12
PS30	118 _{k6}	58	320	290	250 _{h6}	140	100	350	164	324	217.5	171.5	41	107	380	22	20	169	62	17.5	122	14	18	M10	M12
PS30	130 _{k6}	58	320	290	250 _{h6}	140	100	350	164	324	217.5	171.5	41	107	380	22	20	169	62	17.5	122	14	18	M10	M12

Bearing design L (long bearing distance)

	∅v	a0	∏a1	b	∅b1	∅dps	∅e	∅e1	h	H	i	i2	lps0	lps1	lps3	lps5	lps7	m	n2	n3	n4	s	∅s1	s2	s4
PS25	130 _{k6}	58	264	234	250 _{h6}	140	100	300	136	268	282	236	41	171.5	350	22	20	169	69	12.0	122	14	18	M10	M12
PS30	130 _{k6}	58	320	290	250 _{h6}	140	100	350	164	324	282	236	41	171.5	380	22	20	169	62	17.5	122	14	18	M10	M12

Motor connection dimensions

	∅b6	∅d2	∅e6	I _{5max}	∏a6	c	c6	f6	hps1	l7	∅s6	t6
PS25	230 ^{H7}	42/48/55	265	112	250	24.5	95	11	139	31	M12	32.0
PS30	230 ^{H7}	42/48/55	265	112	250	24.5	95	11	139	31	M12	32.0
PS25	250 ^{H7}	42/48/55	300	112	260	24.5	95	11	144	31	M16	32.0
PS30	250 ^{H7}	42/48/55	300	112	260	24.5	95	11	144	31	M16	32.0
PS25 ⁷⁾	300 ^{H7}	42/48/55	350	112	314	26.3	95	11	171	31	M16	26.3
PS30 ⁷⁾	300 ^{H7}	42/48/55	350	112	314	26.3	95	11	171	31	M16	26.3
PS25 ⁷⁾	300 ^{H7}	60	350	142	314	26.3	125	11	171	61	M16	26.3
PS30 ⁷⁾	300 ^{H7}	60	350	142	314	26.3	125	11	171	61	M16	26.3

Instructions	Page
General instructions regarding the dimensional drawings	25
1) Mating plug for the electrical connection of the gear switcher (optional). For designs with the dimensions a6 ≤ 250 mm, you can also mount the housing of the connector in the horizontal position if this is appropriate for the cable guide.	–
2) Venting valve, only for circulation lubrication and installation position EL5	–
3) Access bore hole (on each side of the cooling flange) for lubrication connections E/H	–
4) Venting valve, only for circulation lubrication and installation position EL4	–
5) Venting valve, only for circulation lubrication and installation position EL3	–
6) The cooling flange can be rotated in increments of 90 °	–
7) Option	–

1.3.8 Instructions regarding the dimensional drawings

Instructions

- Dimensions may exceed the requirements of DIN 7168-m due to casting tolerances or the sum of additional tolerances.
- Ring screws that are used to transport the gearbox can be removed and replaced with a new clamping screw after installation. The ring screws are therefore not shown in the dimensional drawings.
- We reserve the right to make modifications to the dimensions due to technical advances.

Depth of the centering holes as per DIN 332-2, shape DR:

Thread	M4	M5	M6	M8	M10	M12	M16	M20	M24
Depth (mm)	10	12.5	16	19	22	28	36	42	50

Information

You can download CAD model of our standard drives from <http://cad.stoeber.de>

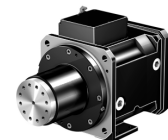

1.4 Type designation

Sample code

PS	25	0	1	M	F	Z	0040	ME
----	----	---	---	---	---	---	------	----

Explanation

Code	Designation	Version
PS	Type	Two-speed gearbox
25	Size	25
30		30
0	Generation	0
1	Stages	1-stage
S	Housing	Short bearing distance
SC		Short bearing distance with cooling flange
M		Medium bearing distance
MC		Medium bearing distance with cooling flange
L		Long bearing distance
LC		Long bearing distance with cooling flange
F	Shaft	Flange shaft
G		Solid shaft or feather key
P		Solid shaft with two feather keys
R		Deep-groove ball bearing
S	Bearing	Angular ball bearing
Z		Cylindrical roller bearing
0040	Transmission ratio (i x 10)	i = 4 (example)
ME	Attachment groups	Motor adapter with EASY-Adapt coupling

To complete the type designation, please indicate the following in addition:

- Installation position, see section 1.5.3.2
- Diameter of solid shaft or flange shaft
- Splash lubrication or circulation lubrication (optional)?
- Oil level indicator for splash lubrication in EL5 (optional)?
- Dimensions of motor connection: pilot, pitch circle, shaft length, shaft diameter, see section 1.3
- Gear switcher with neutral position (optional)?
- Backlash standard or reduced (optional)?
- With matching mating plug for the electrical connection of the gear switcher (optional)?

Available versions

Housing design	S(C)	M(C)	S(C)	M(C)	M(C)	L(C)
Shaft design	G		P		F	
Bearing design						
R	S(C)GR	–	S(C)PR	–	–	–
S	S(C)GS	M(C)GS	S(C)PS	M(C)PS	M(C)FS	–
Z	–	M(C)GZ	–	M(C)PZ	M(C)FZ	L(C)FZ

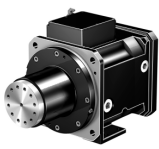

1.5 Product description

1.5.1 General features

Feature	Value
Maximum permitted gear temperature (on the surface of the gear unit)	$\leq 80^{\circ}\text{C}$
Paint	Black RAL 9005
ATEX (94/9/EC)	Not suitable
Protection class	IP55

1.5.2 Ambient conditions

Feature	Value
Transport/storage ambient temperature	-10°C to $+50^{\circ}\text{C}$
Operating ambient temperature	0°C to $+40^{\circ}\text{C}$ (without water cooling) $+10^{\circ}\text{C}$ to $+40^{\circ}\text{C}$ (with water cooling)
Relative humidity	$< 60\%$
Installation altitude	≤ 1000 m above sea level
Shock load	≤ 5 g

1.5.3 Installation

1.5.3.1 Installation conditions

Attaching the gearbox on the machine side

The torques and forces specified in this catalog only apply for the attachment of the gearbox on the machine side using screws of quality 10.9. In addition, the housing of the gearbox must be adjusted at the pilot (H7).

If you are only mounting the gearbox on the foot fastening, radial forces on the output shaft may damage the gearbox. For this type of application, fix the attached motor to the foot fastening of the motor.

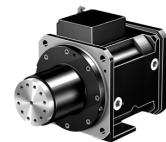

Two-speed PS gearbox



1.5.3.2 Installation positions

The installation position is derived from the gear unit side, which points down (installation position EL2 is not permitted).

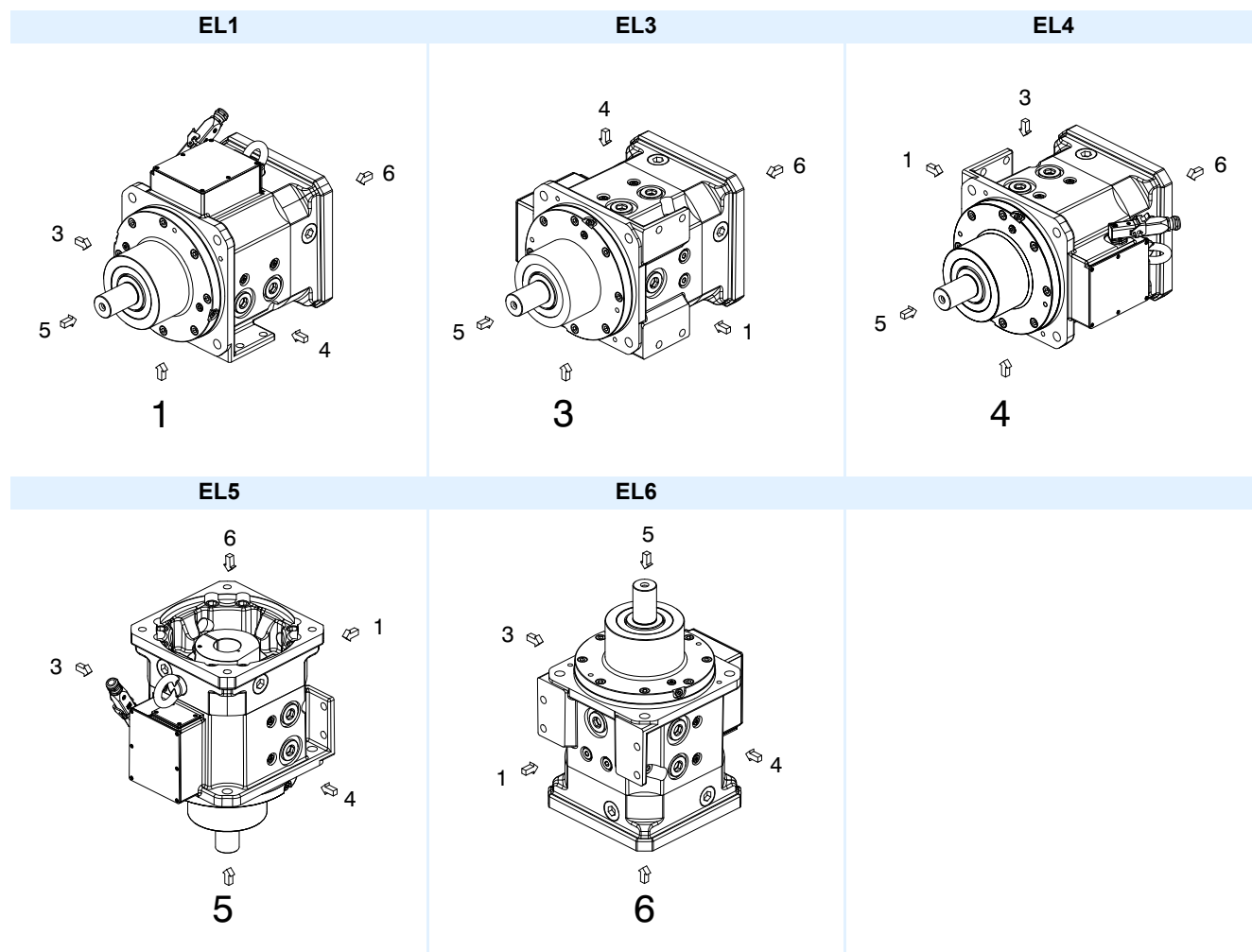

1.5.4 Direction of rotation

The input and output turn in the same direction.

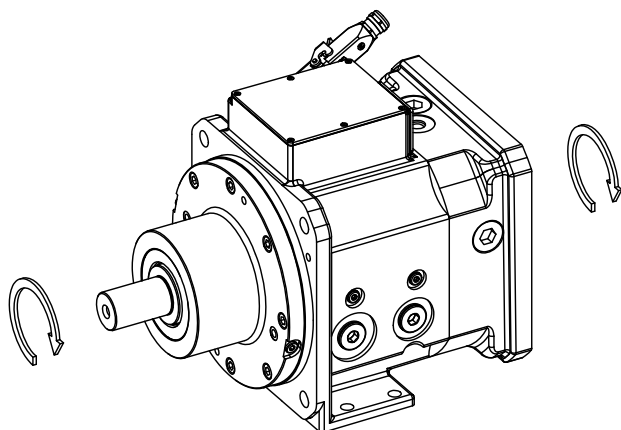

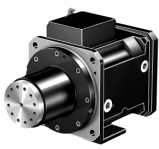

1.5.5 Flange-mounted motor

1.5.5.1 Requirements for the installed motor

We recommend to use a motor with a plain shaft. You can find information about when a motor with foot fastening (design IMB35) is required in sections 1.5.5.2 and 1.5.3.1. The motor to be installed must have the following tolerances to ensure problem-free operation (see also Fig. 1-1):

Feature	Tolerance
Concentricity of the shaft end ¹⁾	25 µm
Coaxiality of the flange centering for the shaft ¹⁾	63 µm
Axial runout of the attachment area of the flange for the shaft ¹⁾	63 µm
Diameter of the motor shaft < 55 mm	k6 ²⁾
Diameter of the motor shaft ≥ 55 mm	m6 ²⁾

1) According to IEC 60072-1 (Precision class)

2) According to DIN EN ISO 286-1

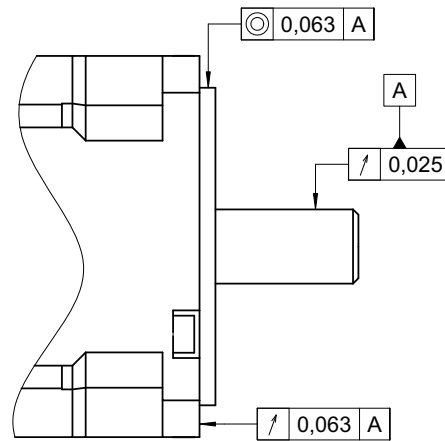
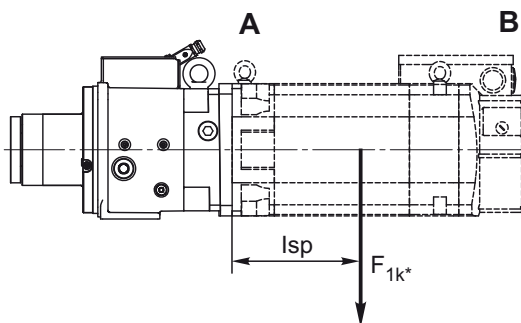

Fig. 1-1: Motor tolerances

1.5.5.2 Maximum permitted breakdown torque on the gear unit output

Formula symbol	Unit	Explanation
F_{1k^*}	N	Static and dynamic loads from motor weight, mass acceleration and vibrations on the gear unit input.
l_{sp}	m	Distance between the center of gravity of the motor and the gear unit input
$M_{1k,max}$	Nm	Maximum permitted breakdown torque on the gear unit output



A = Mounting or output side of the motor
 B = Rear side of the motor

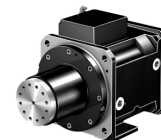

Two-speed PS gearbox

Calculate the maximum permitted breakdown torque of the attached motor as follows:

$$M_{1k,max} = F_{1k*} \cdot I_{sp} \leq 1000 \text{ Nm.}$$

Fix the motor in place on its foot fastening (design IMB35) as well or support it tension-free on the B side if the maximum allowable breakdown torque is exceeded. Note also the instructions in section 1.5.3.1.

1.5.6 Lubrication

The gearbox is lubricated by splash lubrication as standard. As more heat to be dissipated arises at high speeds, an optional connection of the gearbox to a circulating lubrication system with a cooling unit is possible. As a result, the operation of the gearbox in the position EL6 is also possible. Both lubrication types are described in the following sections.

1.5.6.1 Splash lubrication

Different lubrication connections of the gearbox must be made accessible depending on the installation position of the gearbox. For details see this section. You can find the position of the lubrication connections in section 1.5.6.2.

Oil change interval	every 10000 operating hours
Gear oil specification	CLP HC ISO VG 68

The oil quantity depends on the installation position. The oil filling quantity can be found on the nameplate of your gearbox and on the Internet at www.stoeber.de.

Installation position	Filling connection	Outlet connection
EL1	L / O ¹	I
EL3	A / B	C / D
EL4	C / D	A / B
EL5	B / D	E / F / G / H ²

Tab. 1-2: Assignment of the lubrication connections for the installation position

- 1) The "/" character means "or" (L or O)
- 2) The transmission oil must be suctioned out. Outlet connections F and G are not accessible with the cooling flange option

1.5.6.2 Circulation lubrication (optional)

Formula symbol	Unit	Explanation
$\Delta\vartheta$	K	Temperature difference
$q_{v,lub}$	l/min	Volume flow of circulation lubrication
ϑ_1	°C	Temperature at the inlet connection
ϑ_2	°C	Temperature at the return flow connection
ϑ_{amb}	°C	Surrounding temperature

Feature	Value
Specific cooling capacity	$\geq 0.07 \text{ kW/K}$
Absolute cooling capacity	$\geq 1.4 \text{ kW}$ with $\Delta\vartheta = \vartheta_1 - \vartheta_2 = 60 \text{ °C} - 40 \text{ °C} = 20 \text{ °C}$ and $\vartheta_{amb} = 30 \text{ °C}$
Volume flow $q_{v,lub}$	See following table
Filter ¹⁾	Filter fineness 60 μm
Internal diameter of connecting element on the return flow ²⁾	$\geq 21 \text{ mm}$ (G1" thread) $\geq 19 \text{ mm}$ (G3/4" thread)
Gear oil specification ³⁾	CLP HC ISO VG 46

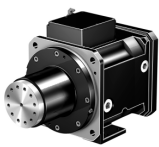

- 1) At the inlet connection of the gearbox
- 2) Pipeline cross sections specified by thread connections should not be limited by screw connection elements
- 3) Other specifications on request

Note

For circulation lubrication, the gearbox is fitted with a venting valve whose position depends on the installation position of the gearbox. For details see section 1.3.

Depending on the installation position and rotary direction, the gearbox must be connected to different connections on the cooling system. For details see this section.

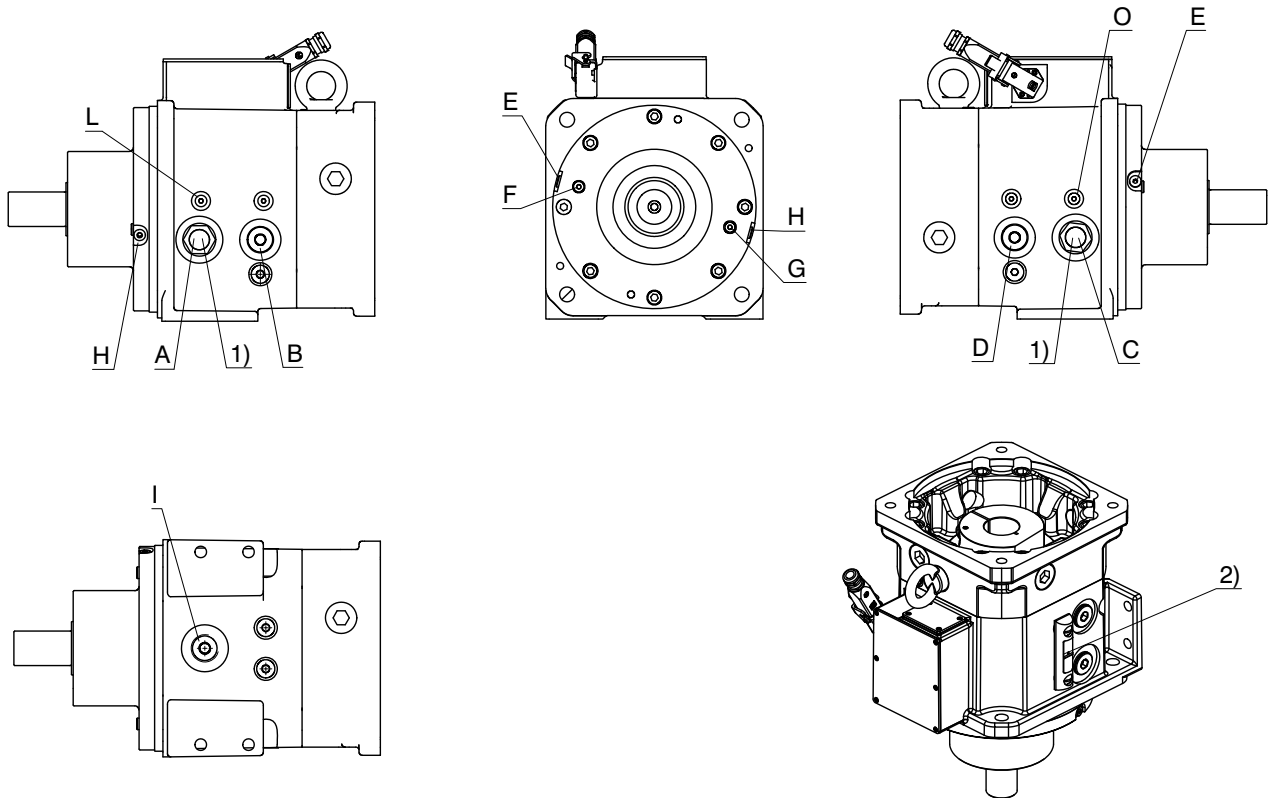

Fig. 1-3: Position of the connections

- 1) Oil inspection glass for splash lubrication and EL1
- 2) Oil level indicator for splash lubrication and EL 5 (option)

Installation position / main direction of rotation	Supply lineconnection 1		Supply lineconnection 2		Return flow connection	
	Designation ¹⁾	q _{v,lub} [l/min]	Designation ¹⁾	q _{v,lub} [l/min]	Designation ¹⁾	q _{v,lub} ²⁾ [l/min]
EL1 / cw ³⁾	B	≥ 2	E/F/G/H	≥ 1	C	> 3
EL1 / ccw ⁴⁾	D	≥ 2	E/F/G/H	≥ 1	A	> 3
EL3 / cw and ccw	D	≥ 2	E/F/G/H	≥ 1	I	> 3
EL4 / cw and ccw	B	≥ 2	E/F/G/H	≥ 1	I	> 3
EL5 / cw and ccw	E/F/G/H	≥ 3	–		B/D	> 3
EL6 / cw and ccw	E/F/G/H	≥ 3	–		A/C/I	> 3

Tab. 1-4: Assignment of the connections for the installation position and rotary direction

- 1) The "/" sign means "or" (E or F or G or H). Connections F and G are not accessible with the cooling flange option
- 2) As a general rule: q_{v,lub} return > q_{v,lub} supply
- 3) cw = clockwise when looking at the output shaft
- 4) ccw = counter-clockwise when looking at the output shaft



1.5.7 Gear switcher

The gear switcher switches the gears of the gearbox. The gear switcher is connected via the installed plug connector to the machine controller. You can find information about the switching logic that is programmed for the gear change in the operating manual of the gearbox. You can find electrical connection values in the following table.

Merkmal	Wert
Switching motor rated voltage ¹	24 V DC ± 10%
Switching motor rated current	0.6 A
Switching motor starting current	2.76 A
Limit switch rated voltage ¹	24 V DC
Limit switch rated current ²	1 A

1) Note voltage losses in lines, contact resistors and increased resistances that arise over time due to corrosion.

2) The limit switch may only be applied with the control current and not the current of the switching motor.

1.5.8 Cooling flange (optional)

The gearbox can be operated at higher speeds with the optional cooling flange (you can find details in section 1.2.1). The heat input of the gearbox in the machine can also be reduced using the cooling flange.

The dimensions of the cooling flange can be found in section 1.3.

You can find the specification of the cooling system that the cooling flange must be connected to in the following table.

Feature	Value
Coolant	Water
Temperature at inlet	10 – 40 °C (max. 5 °C below the surrounding temperature)
Cooling circuit	Closed, with recooling unit; no non-ferrous metals
Cleanliness	Clear, with no suspended matter or dirt (use particle filter ≤ 100 µm if necessary)
pH value	6.5 – 7.5
Hardness	1.43 – 2.5 mmol/l
Salinity	NaCL < 100 ppm, demineralized
Anticorrosive	Max. percentage 25%, neutral relative to S235JK, EN-GJL-HB 215
Flow rate	3 l/min (recommended)
Operating pressure	Max. 3.5 bar (provide a pressure relief valve in the supply line)
Connection thread	G3/8

1.6 Projecting

Formula symbol	Unit	Explanation
F_{2ax}^*	N	Existing axial force on the gear unit output
F_{2ax300}	N	Permitted axial force on the gear unit output for $n_{2m^*} \leq 300 \text{ min}^{-1}$
F_{2axN}	N	Permitted nominal axial force on the gear unit output
F_{2rad}^*	N	Existing radial force on the gear unit output
$F_{2rad300}$	N	Permitted radial force on the gear unit output for $n_{2m^*} \leq 300 \text{ min}^{-1}$
F_{2radN}	N	Permitted nominal axial force on the gear unit output
f_{B_T}	–	Operational factor – temperature
$M_{2.1^*} - M_{2.6^*}$	Nm	Existing torque in the relevant time segment (1 to 6)

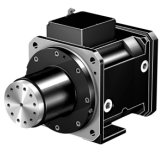

M_{2,n^*}	Nm	Existing torque in the n-th time segment
M_{2k^*}	Nm	Existing breakdown torque on the gear unit output
M_{2k300}	Nm	Permitted breakdown torque on the gear unit output for $n_{2m^*} \leq 300 \text{ min}^{-1}$
M_{2kN}	Nm	Permitted nominal breakdown torque on the gear unit output
n_{1m^*}	rpm	Existing average input speed
n_{1max^*}	rpm	Existing maximum input speed
n_{2m^*}	rpm	Existing average output speed
$n_{2m,1^*} - n_{2m,6^*}$	rpm	Existing average output speed in the relevant time segment (1 to 6)
n_{2m,n^*}	rpm	Existing average output speed in the n-th time segment
$t_{1^*} - t_{6^*}$	s	Duration of the relevant time segment (1 to 6)
t_{n^*}	s	Duration of the n-th time segment
ϑ_{amb}	°C	Surrounding temperature

1.6.1 Permitted speeds

S1 mode

The maximum permitted input speeds n_{1maxH} or n_{1maxV} in S1 mode specified in section 1.2.1 depend on the surrounding temperature ϑ_{amb} (see following table). The maximum permitted input speeds for your application can be calculated as follows:

For EL1, EL3, EL4:

$$n_{1max^*} = \frac{n_{1maxH}}{fB_T}$$

For EL5, EL6:

$$n_{1max^*} = \frac{n_{1maxV}}{fB_T}$$

Surrounding temperature ϑ_{amb}	Operational factor fB_T
$\leq 20 \text{ °C}$	1.0
$\leq 30 \text{ °C}$	1.1
$\leq 40 \text{ °C}$	1.2

Tab. 1-5: Operational factor – temperature

S6 mode

In S6 mode of the gearbox, the following condition must be complied with for the existing average input speed: $n_{1m^*} < n_{1maxH}$ or $n_{1m^*} < n_{1maxV}$. Below you will find information about the calculation of n_{1m^*} .

$$n_{1m^*} = n_{2m^*} \cdot i$$

$$n_{2m^*} = \frac{|n_{2m,1^*}| \cdot t_{1^*} + \dots + |n_{2m,n^*}| \cdot t_{n^*}}{t_{1^*} + \dots + t_{n^*}}$$

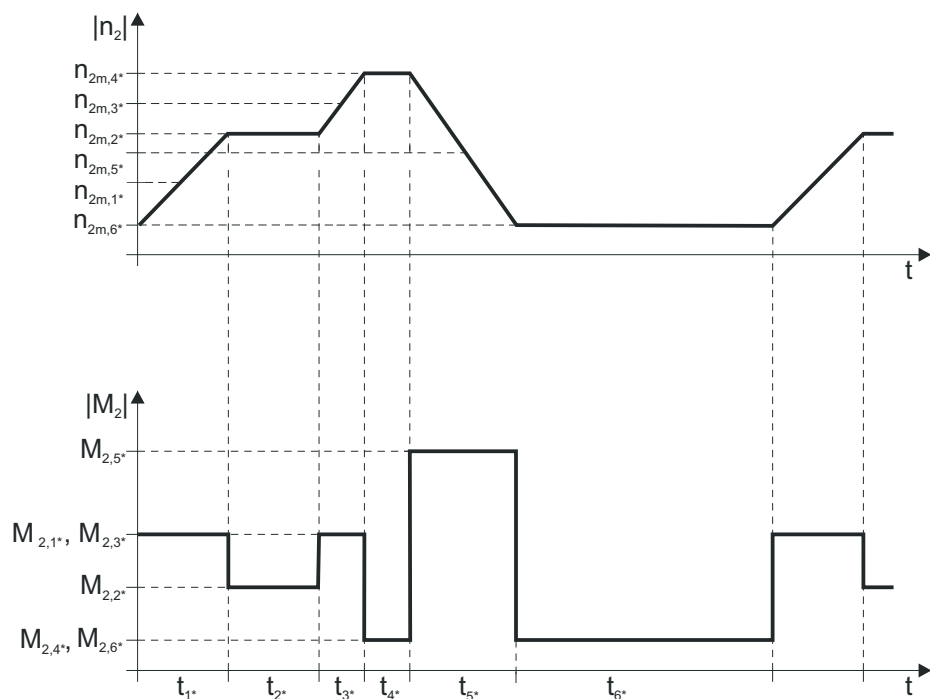
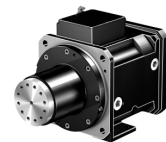

Fig. 1-6: Sample diagram for S6 operation

1.6.2 Permissible shaft loads

The values specified in the following tables for permitted shaft loads apply

- for shaft dimensions see the catalog
- for output speeds $n_{2m^*} \leq 300$ rpm
 $(F_{2axN} = F_{2ax300}; F_{2radN} = F_{2rad300}; M_{2kN} = M_{2k300})$
- only if the lateral forces acting on the gearbox are supported by the pilot of the gearbox housing

1.6.2.1 Shaft design G/ P (solid shaft)

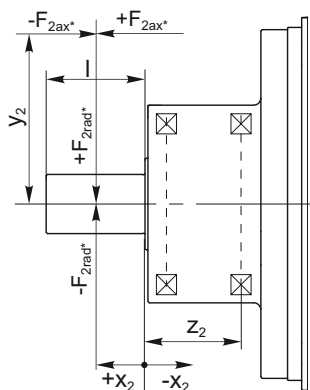
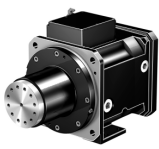

Fig. 1-7: Application of force points for the solid shaft

SR design (short bearing distance, deep-groove ball bearing)

Typ	z_2 [mm]	x_{2min} [mm]	x_{2max} [mm]	F_{2ax300} [N]	$F_{2rad300}$ [N]	M_{2k300} [Nm]
PS25	61.0	-43.0	110.0	1100	1900	182
PS30	61.0	-43.0	110.0	1100	1900	182



SS design (short bearing distance, angular ball bearing)

Typ	z ₂ [mm]	x _{2min} [mm]	x _{2max} [mm]	F _{2ax300} [N]	F _{2rad300} [N]	M _{2k300} [Nm]
PS25	94.0	-43.0	110.0	2150	4300	552
PS30	94.0	-43.0	110.0	2150	4300	552

MS design (average bearing distance, angular ball bearing)

Typ	z ₂ [mm]	x _{2min} [mm]	x _{2max} [mm]	F _{2ax300} [N]	F _{2rad300} [N]	M _{2k300} [Nm]
PS25	133.0	-63.0	110.0	2300	4600	770
PS30	133.0	-63.0	110.0	2300	4600	770

MZ design (average bearing distance, cylindrical roller bearing)

Typ	z ₂ [mm]	x _{2min} [mm]	x _{2max} [mm]	F _{2ax300} [N]	F _{2rad300} [N]	M _{2k300} [Nm]
PS25	101.0	-38.0	110.0	1750	8750	1185
PS30	101.0	-38.0	110.0	1750	8750	1185

For output speeds > 300 min⁻¹ permitted shaft loads can be determined according to the following formulas:

$$F_{2axN} = \frac{F_{2ax300}}{\sqrt[3]{\frac{n_{2m^*}}{300\text{min}^{-1}}}}$$

$$F_{2radN} = \frac{F_{2rad300}}{\sqrt[3]{\frac{n_{2m^*}}{300\text{min}^{-1}}}}$$

$$M_{2kN} = \frac{M_{2k300}}{\sqrt[3]{\frac{n_{2m^*}}{300\text{min}^{-1}}}}$$

The values specified for radial forces are for centered application of force (x₂ = l / 2). If force is applied eccentrically, the permitted radial forces can be determined from the permitted breakdown torque M_{2k*} according to the following formula (limit values for x₂ are indicated in the previous tables):

$$M_{2k^*} = \frac{2 \cdot F_{2ax^*} \cdot y_2 + F_{2rad^*} \cdot (x_2 + z_2)}{1000} \leq M_{2k300}$$

1.6.2.2 Shaft version F (flange shaft)

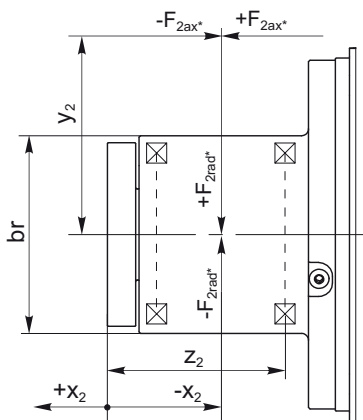

Fig. 1-8: Application of force points for the flange shaft



Two-speed PS gearbox

MS design (average bearing distance, angular ball bearing)

Typ	z ₂ [mm]	x _{2min} [mm]	x _{2max} [mm]	F _{2ax300} [N]	F _{2rad300} [N]	M _{2k300} [Nm]
PS25	154.0	-83.0	83.0	2300	11000	770
PS30	154.0	-83.0	83.0	2300	11000	770

MZ design (average bearing distance, cylindrical roller bearing)

Typ	br [mm]	z ₂ [mm]	x _{2min} [mm]	x _{2max} [mm]	F _{2ax300} [N]	F _{2rad300} [N]	M _{2k300} [Nm]
PS25	116.0	122.0	-80.0	80.0	1750	23000	943
PS25	140.0	121.0	-81.0	81.0	1750	30000	1185
PS30	116.0	122.0	-80.0	80.0	1750	23000	943
PS30	140.0	121.0	-81.0	81.0	1750	30000	1185

LZ design (long bearing distance, cylindrical roller bearing)

Typ	z ₂ [mm]	x _{2min} [mm]	x _{2max} [mm]	F _{2ax300} [N]	F _{2rad300} [N]	M _{2k300} [Nm]
PS25	186.0	-111.0	111.0	1750	30000	2235
PS30	186.0	-111.0	111.0	1750	30000	2235

For output speeds > 300 min⁻¹ permitted shaft loads can be determined according to the following formulas:

$$F_{2axN} = \frac{F_{2ax300}}{\sqrt[3]{\frac{n_{2m^*}}{300\text{min}^{-1}}}} \quad F_{2radN} = \frac{F_{2rad300}}{\sqrt[3]{\frac{n_{2m^*}}{300\text{min}^{-1}}}} \quad M_{2kN} = \frac{M_{2k300}}{\sqrt[3]{\frac{n_{2m^*}}{300\text{min}^{-1}}}}$$

The specified values for radial forces refer to x_{2min} in the tables above. For a different application of force, the permitted radial forces can be determined from the permitted breakdown torque M_{2k*} according to the following formula (limit values for x₂ are indicated in the previous tables):

$$M_{2k^*} = \frac{F_{2ax^*} \cdot y_2 + F_{2rad^*} \cdot (x_2 + z_2)}{1000} \leq M_{2k300}$$

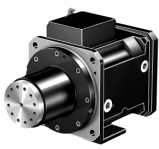

1.7 Service

1.7.1 Close contact with customers worldwide

Germany

STÖBER ANTRIEBSTECHNIK GmbH + Co. KG
Kieselbronner Straße 12
75177 Pforzheim

Fon +49 7231 582-0
sales@stoerber.de
www.stoerber.com

24h service hotline +49 180 5 786323

STOBER service specialists can be reached 24/7 and can support you with expertise and assistance if service is required:

- 4 sales centers in Germany
- Worldwide presence in over 40 countries
- STÖBER SERVICE NETWORK with over 80 service partners worldwide

Subsidiaries:

STOBER AUSTRIA www.stoerber.at Fon +43 7613 7600-0 sales@stoerber.at	STOBER SOUTH EAST ASIA www.stoerber.sg Fon +65 65112912 sales@stoerber.sg
STOBER CHINA www.stoerber.cn Fon +86 10 6590 7391 sales@stoerber.cn	STOBER SWITZERLAND www.stoerber.ch Fon +41 56 496 96 50 sales@stoerber.ch
STOBER FRANCE www.stoerber.fr Fon +33 4 78.98.91.80 sales@stoerber.fr	STOBER TAIWAN www.stoerber.tw Fon +886 2 2216 3428 sales@stoerber.tw
STOBER TURKEY www.stoerber.com Fon +90 212 338 8014 sales-turkey@stoerber.com	STOBER ITALY www.stoerber.it Fon +39 02 93909570 sales@stoerber.it
STOBER UNITED KINGDOM www.stoerber.co.uk Fon +44 1543 458 858 sales@stoerber.co.uk	STOBER JAPAN www.stoerber.co.jp Fon +81 3 5395 6788 sales@stoerber.co.jp
STOBER USA www.stoerber.com Fon +1 606 759 5090 sales@stoerber.com	

1.7.2 Trademarks

Products that are registered as trademarks are not specially indicated in this documentation. Existing property rights (patents, trademarks, protection of utility models) are to be observed.

1.7.3 Sales and delivery conditions

You can find our current sales and delivery conditions at www.stoerber.de

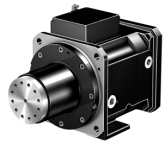

Two-speed PS gearbox

1.7.4 Imprint

Catalog PS Two-speed Gearbox 442712_en.00.

For the latest pdf files visit us on the Internet at www.stoeber.de

STOBER PRODUCT RANGE

Geared Motors	Synchronous Servo Geared Motors (ID 442437)
	Planetary Geared Motors
	Right-Angle Planetary Geared Motors
	Helical Geared Motors
	Offset Helical Geared Motors
	Helical Bevel Geared Motors
	Helical Worm Geared Motors
	Synchronous Servo Geared Motors ED/EK (ID 441712)
	Planetary Geared Motors
	Right-Angle Planetary Geared Motors
	Helical Geared Motors
	Offset Helical Geared Motors
	Helical Bevel Geared Motors
	Helical Worm Geared Motors
	Asynchronous Geared Motors IE2 (ID 442356)
	Helical Geared Motors
	Offset Helical Geared Motors
	Helical Bevel Geared Motors
	Helical Worm Geared Motors
	Asynchronous Geared Motors (ID 441809)
	Helical Geared Motors
	Offset Helical Geared Motors
	Helical Bevel Geared Motors
	Helical Worm Geared Motors
Electronics	Drive Controllers/Controller
	Motion Controllers MC6 (ID 442711)
	Drive Controllers SD6 (ID 442711)
	Servo Inverters SDS 5000 (ID 442711)
	Servo Inverters MDS 5000 (ID 442711)
	Frequency Inverters MDS 5000 (ID 442356)
	Frequency Inverters FDS 5000 (ID 442356)
Gear Units	Servo Gear Units (ID 442257)
	Planetary Gear Units
	Right-Angle Planetary Gear Units
	Helical Gear Units
	Offset Helical Gear Units
	Helical Bevel Gear Units
	Helical Worm Gear Units
	Power Transmission Gear Units (ID 441834)
	Helical Gear Units
	Offset Helical Gear Units
	Helical Bevel Gear Units
	Helical Worm Gear Units
	Gearboxes (ID 442712)
	Two-Speed Gearboxes
Motors	Synchronous Servo Motors EZ (ID 442437/442711)
	Synchronous Servo Motors with Hollow Shaft EZHD (ID 442437/442711)
	Synchronous Servo Geared Motors with Hollow Shaft EZHP (ID 442437/442711)
	Synchronous Servo Motors for Screw Drives EZS/EZM (ID 442437/442711)
	Synchronous Servo Motors ED/EK (ID 441712)
	Asynchronous Motors IE2 (ID 442356)
	Asynchronous Motors (ID 441809)
Rack and Pinion Drives	ZTRS/ZTR/ZR (ID 442225)
	ZV (ID 442506)



STÖBER ANTRIEBSTECHNIK GmbH + Co. KG

Kieselbronner Str. 12
75177 PFORZHEIM
GERMANY
Tel. +49 7231 582-0
eMail: mail@stoerber.de
www.stoerber.com

24h Service Hotline +49 1805 786323

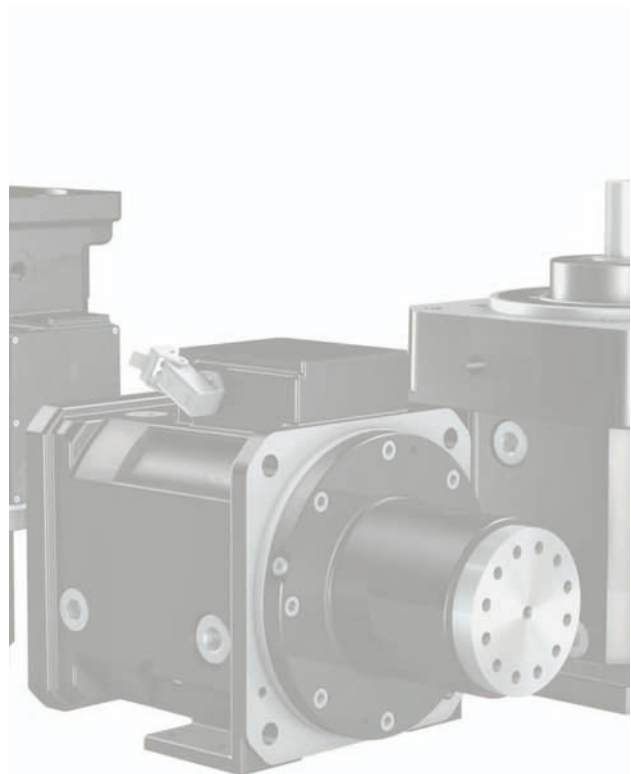

www.stoerber.com