

Performance Overview of Mechanical Linear Drives and Compact Modules with Toothed Belt Drive or Rack-and-Pinion Drive (AZSS)

Description	Toothed belt	F _x [N]	F _y [N]	F _z [N]	-F _z [N]	M _x [Nm]	M _y [Nm]	M _z [Nm]	M _{idle} [Nm]	d _s [mm]	s _{max} [mm]	L _{max} [mm]
Beta 40-ZGS	16 AT5-E	500	80	150	75	6	6	8	0.30	0.08	2780	3000
Beta 40-ZSS	16 AT5-E	500	500	600	300	12	30	30	0.30	0.08	850	1070
Beta 50-C-ZRS	20 AT5-E	700	300	600	400	30	50	50	0.40	0.08	7710	8000
Beta 50-C-ARS	20 AT5-E	700	300	600	400	30	50	50	1.50	0.08	7710	8000
Beta 60-ZSS	25 AT5-E	850	500	1400	800	50	160	100	1.10	0.08	7620	8000
Beta 70-C-ZRS	32 AT5-E	1100	300	1000	400	35	120	50	1.20	0.08	7640	8000
Beta 70-C-ZSS	32 AT5-E	1100	600	1800	1200	60	180	120	1.20	0.08	6840	7200
Beta 70-C-ARS	32 AT5-E	900	300	1000	400	35	120	50	1.00	0.08	7640	8000
Beta 70-C-ASS	32 AT5-E	900	600	1800	1200	60	180	120	1.00	0.08	7640	8000
Beta 80-ZRS	32 AT5-E	1350	500	1500	800	50	180	100	1.50	0.08	7600	8000
Beta 80-ZSS	32 AT5-E	1350	800	3000	2000	100	250	250	1.50	0.08	7600	8000
Beta 80-C-ZRS	32 AT10	2200	1000	2500	1500	100	300	180	1.80	0.08	7600	8000
Beta 80-C-ZSS	32 AT10	2200	1600	4000	3000	300	500	500	1.80	0.08	7600	8000
Beta 80-ARS	32 AT10	1000	500	1500	800	50	180	100	1.50	0.08	7590	8000
Beta 80-ASS	32 AT10	1000	800	3000	2000	100	250	250	1.50	0.08	7590	8000
Beta 100-ZRS	40 AT10	2800	1000	2500	1200	200	250	200	2.50	0.08	7420	7900
Beta 100-ZSS	40 AT10	2800	1000	3000	2000	200	250	250	2.50	0.08	7420	7900
Beta 100-D-ZSS	40 AT10-E	1500	1800	4000	3000	350	750	750	5.00	0.08	7720	8100
Beta 100-D-ASS	40 AT10-E	2200	1800	4000	3000	350	950	950	2.50	0.08	7680	8100
Beta 110-ZRS	50 ATL10	4000	2000	5000	2500	300	600	450	3.50	0.08	7520	8100
Beta 110-ZSS	50 ATL10	4000	3000	8000	4000	400	800	600	3.50	0.08	7520	8100
Beta 110-ARS	50 ATL10	2000	2000	5000	2500	300	600	450	3.50	0.08	7440	8100
Beta 110-ASS	50 ATL10	2000	3000	8000	4000	400	800	600	3.50	0.08	7440	8100
Beta 120-ZRS	50 ATL10	4000	2500	5000	3000	350	700	500	3.20	0.08	7520	8100
Beta 120-ZSS	50 ATL10	4000	3000	8000	4000	400	800	600	3.20	0.08	7520	8100
Beta 120-C-ZSS	60ATL10	4800	4000	12000	6000	600	1500	1000	4.50	0.08	7500	8100
Beta 140-ZRS	50 AT10-E	4000	2500	5000	3000	350	700	500	3.50	0.08	7540	8100
Beta 140-ZSS	50 AT10-E	4000	2500	6000	4000	500	1000	1000	3.50	0.08	7540	8100
Beta 140-ARS	50 AT10-E	2500	2500	5000	3000	350	700	500	3.50	0.08	7470	8100
Beta 140-ASS	50 AT10-E	2500	2500	6000	4000	500	1000	1000	3.50	0.08	7470	8100
Beta 140-C-ZSS	50 AT10-E	4000	3200	7500	5000	600	1200	1200	3.50	0.08	7470	8100
Beta 140-C-ASS	50 AT10-E	2500	3200	7500	5000	600	1200	1200	3.50	0.08	7470	8100
Beta 165-ZSS	75 ATS15	10000	5000	15000	8000	700	1400	1100	12.00	0.08	6920	7700
Beta 180-ZSS	75 AT10	6000	6000	12000	6000	1500	3000	1500	8.00	0.08	5500	6200
Beta 180-ASS	75 AT10	3500	6000	12000	6000	1500	3000	1500	8.00	0.08	5470	6200
Beta 180-C-ZSS	75 AT10	6000	8000	15000	8000	1800	3600	1800	8.00	0.08	5500	6200
Beta 180-C-ASS	75 AT10	3500	8000	15000	8000	1800	3600	1800	8.00	0.08	5470	6200
Delta 90-ZRS	32 AT5-E	800	500	1000	1000	60	80	80	1.50	0.08	3720	4000
Delta 110-C-ZSS	50 AT5-E	950	1200	3000	1500	500	550	550	2,00	0,08	7820	8100
Delta 145-C-ZSS	60 AT5-E	2000	2500	5000	3000	800	1000	1000	3,00	0,08	7700	8100
Delta 200-ZSS	75 AT10	6000	5000	8000	5000	3500	4300	3200	3.80	0.08	1520	2000
Delta 240-ZSS	50 AT10-E	2500	6000	12000	8000	4500	6000	4500	5.50	0.08	2550	3000
Delta 240-C-ZSS	60 ATL10	3800	6000	12000	8000	4500	6000	4500	5.50	0.08	7340	8000

For mechanical linear drives with roller guides, the static load rating (C_{stat}) applies for static loads.

- M_{idle} = Idle torque ± 30%
- d_s = Repeat accuracy ±
- s_{max} = Maximum standard stroke length (longer on request)
- L_{max} = Maximum standard length (longer on request)

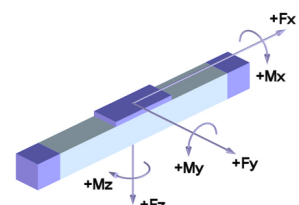

Description	Screw Drive	F _x [N]	F _y [N]	F _z [N]	-F _z [N]	M _x [Nm]	M _y [Nm]	M _z [Nm]	M _{idle} [Nm]	d _{pn/ps} [mm]	d _s [mm]	SA	s _{max} [mm]	L _{max} [mm]
Beta 40-SGS	1205 / 1210	1000	80	150	75	6	6	8	0,30	0,08 / 0,03	0,03	2	890	1090
Beta 40-SSS		1000	500	600	300	12	30	30	0,30	0,08 / 0,03	0,03	2	890	1090
Beta50-C-SRS	1205 / 1210	1000	300	600	400	30	60	50	0,30	0,08 / 0,03	0,03	-	860	1090
Beta 60-SSS	2005 / 2010	4000	600	1800	1200	60	180	120	0,70	0,08 / 0,03	0,03	8	5220	5500
Beta 60-SGV	2020 / 2050	4000	-	-	-	-	-	-	0,70	0,08 / 0,03	0,03	8	5220	5500
Beta 70-C-SRS	1605 / 1610	2000	300	1000	400	35	120	60	0,35	0,08 / 0,03	0,03	8	3725	4000
Beta 70-C-SSS	1620 / 1640	2000	600	1800	1200	60	180	120	0,40	0,08 / 0,03	0,03	8	3725	4000
Beta 80-SRS	2005 / 2010	4000	500	1500	800	50	180	100	0,60	0,08 / 0,03	0,03	8	5220	5600
Beta 80-SSS	2020 / 2050	4000	800	3000	2000	100	250	250	0,80	0,08 / 0,03	0,03	8	5220	5600
Beta 80-SGV	2505 / 2510 2525 / 2550	6000	-	-	-	-	-	-	1,00	0,1 / 0,04	0,03	8	5220	5600
Beta 100-D-SSS	2005 / 2010 2020 / 2050	4000	1800	4000	3000	350	750	750	1,30	0,08 / 0,03	0,03	8	5260	5600
Beta 110-SRS	2505 / 2510	6000	3000	5000	2500	400	800	600	1,00	0,1 / 0,04	0,03	10	5120	5600
Beta 110-SSS	2525 / 2550	6000	2000	8000	4000	300	600	450	1,50	0,1 / 0,04	0,03	10	5120	5600
Beta 110-C-SGV	4005 / 4010 4020 / 4040	16000	-	-	-	-	-	-	1,50	0,1 / 0,04	0,03	6	5120	5600
Beta 120-C-SSS	3205 / 3210 3220 / 3240 3260	12000	4000	12000	6000	600	1500	1000	2,00	0,1 / 0,04	0,03	10	5120	5600
Beta 140-SRS	2505 / 2510 2525 / 2550	6000	2500	5000	3000	350	700	500	1,00	0,1 / 0,04	0,03	10	5120	5600
Beta 140-SSS		6000	2500	6000	4000	500	1000	1000	1,50	0,1 / 0,04	0,03	10	5120	5600
Beta 140-C-SSS		6000	3200	7500	5000	600	1200	1200	1,50	0,1 / 0,04	0,03	10	5120	5600
Beta 165-SSS	4005 / 4010	18000	5000	15000	8000	700	1400	1100	3,00	0,1 / 0,04	0,03	8	5010	5600
Beta 165-SGV	4020 / 4040	18000	-	-	-	-	-	-	3,00	0,1 / 0,04	0,03	8	5020	5600
Beta 165-C-SGV	5010 / 5020	25000	-	-	-	-	-	-	3,20	0,1 / 0,04	0,03	6	5020	5600
Beta 165-C-SSF	5010 / 5020	25000	5000	15000	8000	800	1800	1400	3,20	0,1 / 0,04	0,03	6	5010	5600
Beta 180-SSS	3205 / 3210 3220 / 3240	12000	6000	12000	6000	1500	3000	1500	2,50	0,1 / 0,04	0,03	8	5030	5600
Beta 180-C-SSS	3260	12000	8000	15000	8000	1800	3600	1800	2,50	0,1 / 0,04	0,03	8	5030	5600
Delta 90-SRS	1205 / 1210	1000	500	1000	1000	60	80	80	0,80	0,08 / 0,03	0,03	2	1185	1500
Delta 110-C-SSS	1605 / 1610 1620 / 1640	2000	1200	3000	1500	500	550	550	1,00	0,08 / 0,03	0,03	8	5455	5600
Delta 145-C-SSS	2005 / 2010 2020 / 2050	4000	2500	5000	3000	800	1000	1000	1,00	0,08 / 0,03	0,03	8	5275	5600
Delta 200-SSS	3205 / 3210	10000	5000	8000	5000	3500	4300	3200	2,80	0,1 / 0,04	0,03	4	1620	2000
Delta 240-SSS	3220 / 3240	12000	6000	12000	8000	4500	6000	4500	2,80	0,1 / 0,04	0,03	4	2600	3000
Delta 240-C-SSS	3260	12000	6000	12000	8000	4500	6000	4500	2,80	0,1 / 0,04	0,03	4	5400	5800
Alpha 15-B-155	2005 / 2010 2020 / 2050	4000	2000	20000	15000	1000	900	400	0,35	0,08 / 0,03	0,03	4	1235	1500
Alpha 20-B-225	2505 / 2510 2525 / 2550	6000	5000	58000	40000	4000	3000	1200	1,20	0,1 / 0,04	0,03	4	1645	2000
Alpha 30-B-325	3205 / 3210 3220 / 3240	12000	11000	95000	63000	6300	75000	3750	1,60	0,1 / 0,04	0,03	4	2540	3000
Alpha 35-B-455	4005 / 4010 4020 / 4040	18000	14000	120000	80000	12000	10000	5000	2,50	0,1 / 0,04	0,03	4	2420	3000

For mechanical linear drives with roller guides, the static load rating (C_{stat}) applies for static loads.

- M_{idle} = Idle torque ± 30%
- d_{pn/ps} = Axial clearance (normal / low backlash)
- d_s = Repeat accuracy ±
- SA = Maximum number of spindle supports
- s_{max} = Maximum standard stroke length without spindle support (longer on request)
- L_{max} = Maximum standard length (longer on request)

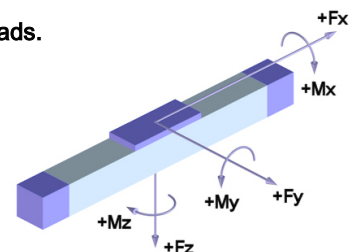

Chapter D

Compact Module

HSB-delta[®]

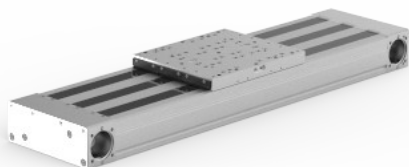
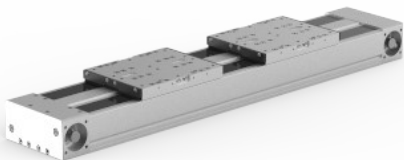
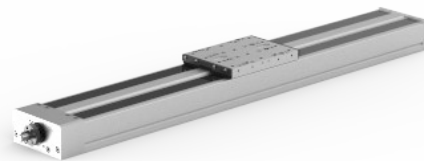
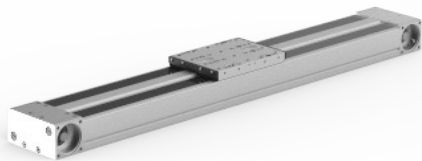
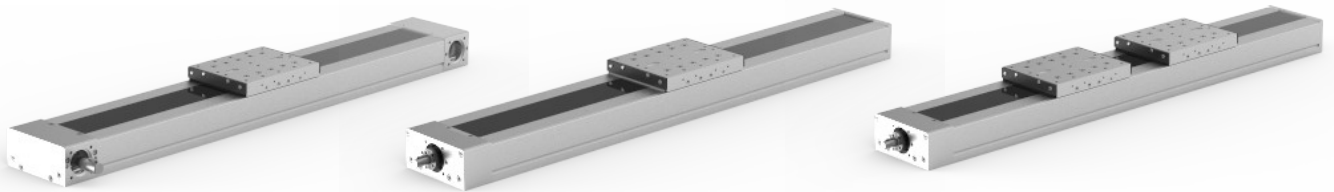

with toothed belt drive and roller guide (ZRS)

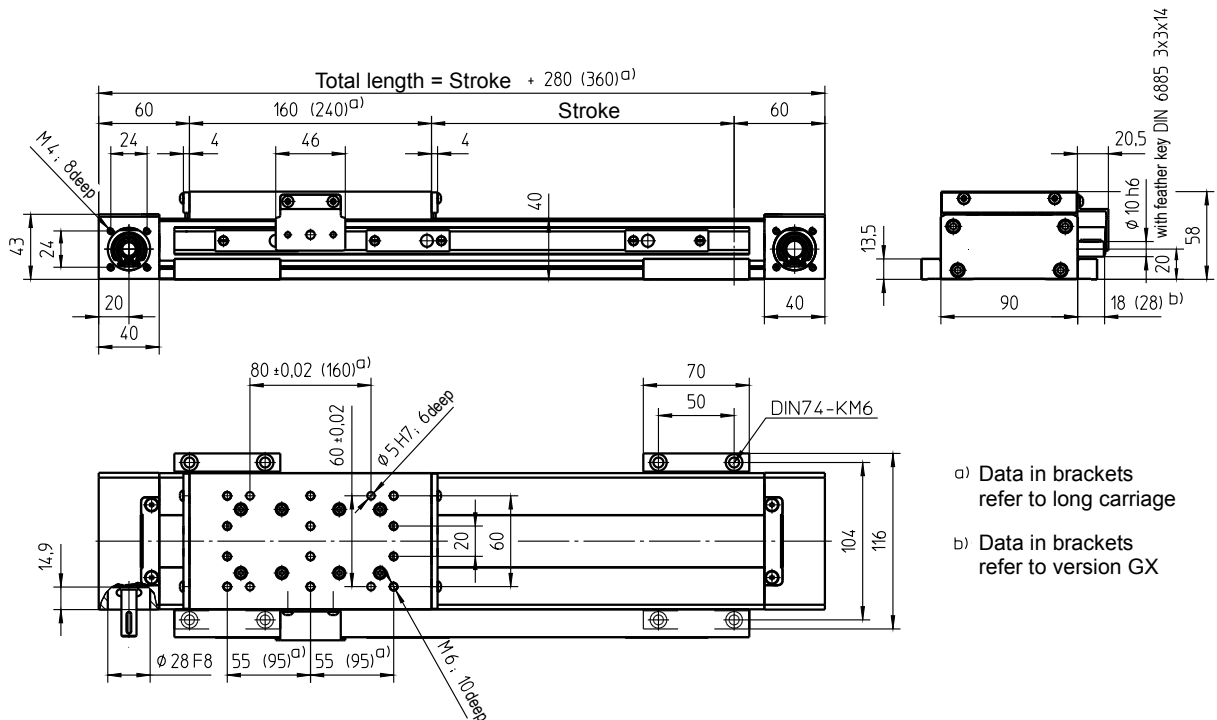

- a) Data in brackets refer to long carriage
- b) Data in brackets refer to version GX

Weights ZRS

Basic length without stroke:	2.95 kg
100 mm stroke:	0.42 kg
Entire carriage 160 mm:	1.30 kg
Entire carriage 240 mm:	1.85 kg
Max. total length:	4000 mm

Technical Data ZRS

Max. total speed:	5.00 m/s
Max. acceleration:	30 m/s ²
Repeat accuracy:	± 0.08 mm
Idle torque:	2.00 Nm
Moment of inertia:	4.65 · 10 ⁻⁴ kgm ²
Drive element:	Toothed belt 32 AT5-E
Stroke per revolution:	100 mm

Forces and moments

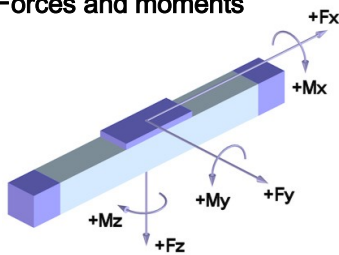

ZRS	
Forces	Dynamic [N]
F _x ^{d)}	800
F _y	500
F _z	1000
-F _z	1000
Moments	Dynamic [Nm]
M _x	60
M _y	80 (110)
M _z	80 (110)

^{d)} Maximum value (see diagram "F_x -v-Diagram")
Data in brackets refer to long carriage (240)

F_x - v - Diagram

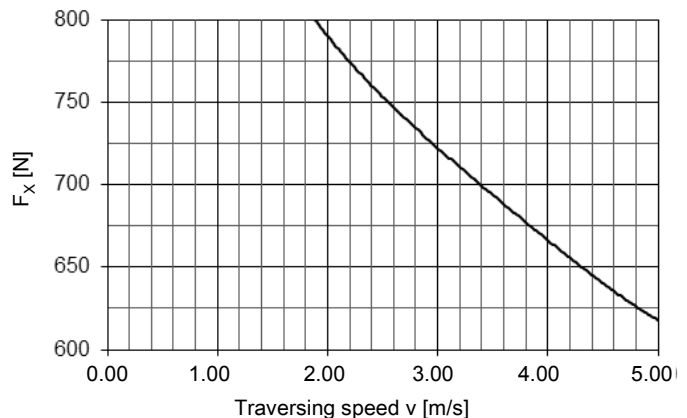

>> Note << Drive shaft is not changeable
Please define position, e.g. "AZ1"! (See Ordering Code)

with ball screw (KGT) and roller guide (SRS)

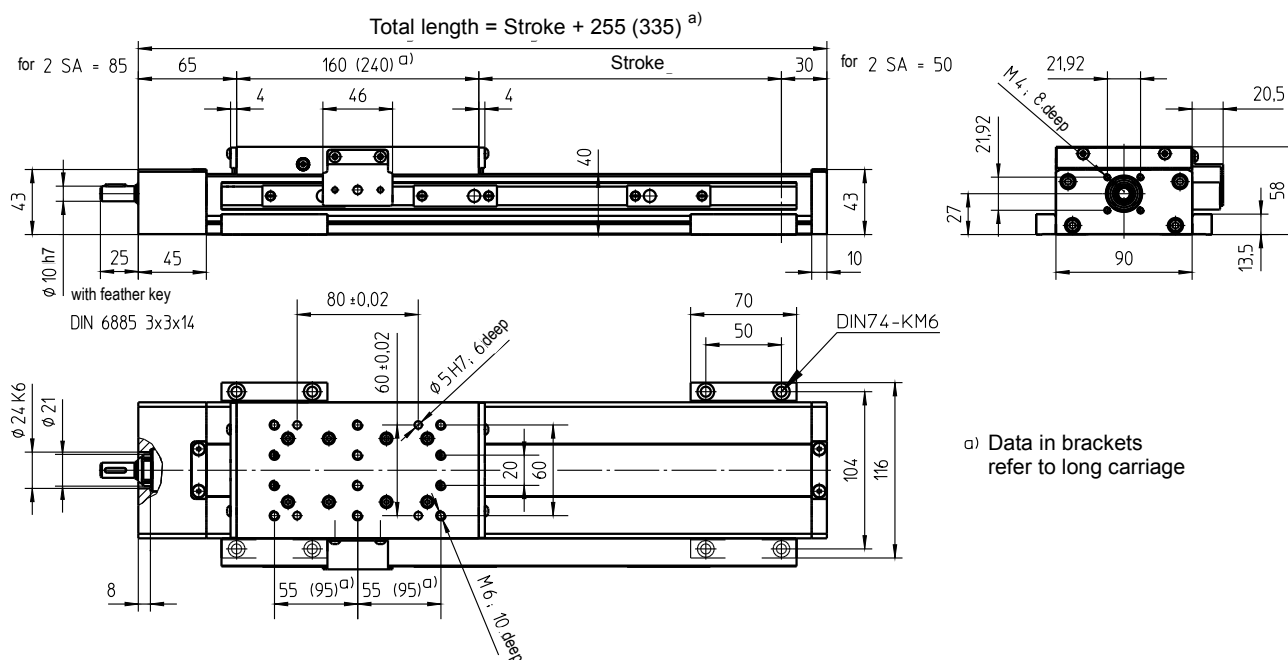

Weights

SRS

Basic length without stroke:	3.25 kg
100 mm stroke:	0.47 kg
Entire carriage 160 mm:	1.30 kg
Entire carriage 240 mm:	1.85 kg
Max. total length:	1500 mm

Technical Data

SRS

Max. total speed:	0.50 m/s
Max. acceleration:	20 m/s ²
Repeat accuracy:	± 0.03 mm (KGT)
Idle torque:	0.30 Nm

Forces and moments

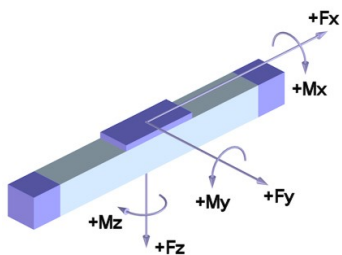

Forces	Dynamic [N]
F_x	1000
F_y	500
F_z	1000
$-F_z$	1000
Moments	Dynamic [Nm]
M_x	60
M_y	80 (110)
M_z	80 (110)

Data in brackets refer to long carriage (240)

Drive element

KGT

Max. rotation speed:	3000 min ⁻¹
Diameter:	12 mm
Pitch:	5 / 10 mm
Moment of inertia:	1.20 · 10 ⁻⁵ kgm ² /m

Spindle support (SA)

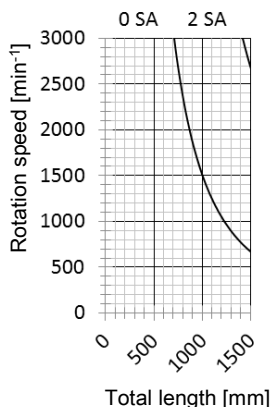

with toothed belt drive and double linear guide (ZSS)

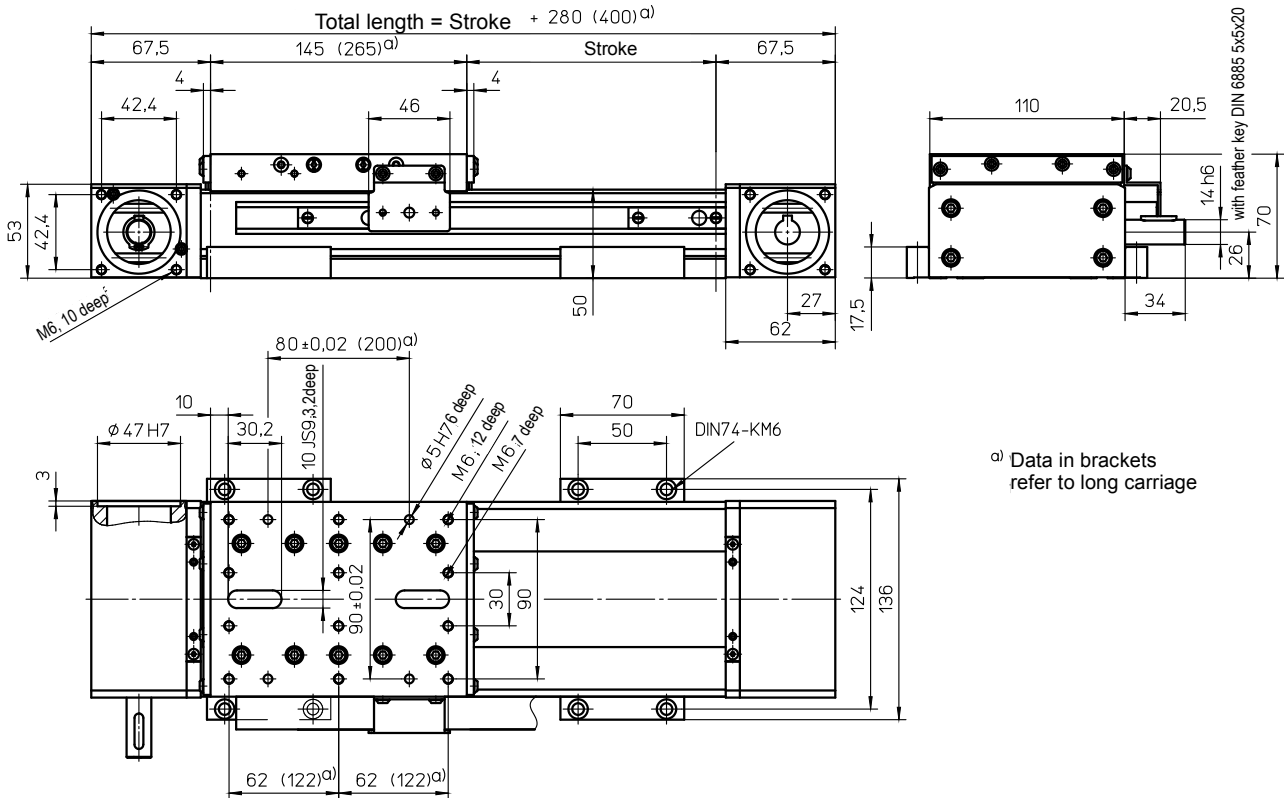

a) Data in brackets refer to long carriage

Weights

ZSS

Basic length without stroke:	5.10 kg
100 mm stroke:	0.80 kg
Entire carriage 145 mm:	2.20 kg
Entire carriage 265 mm:	3.15 kg
Max. total length:	4000 mm

Technical Data

ZSS

Max. total speed:	5.00 m/s
Max. acceleration:	40 m/s ²
Repeat accuracy:	± 0.08 mm
Idle torque:	2.0 Nm
Moment of inertia:	7.60 · 10 ⁻⁴ kgm ²
Drive element:	Toothed belt 50 AT5-E
Stroke per revolution:	110 mm

Forces and moments

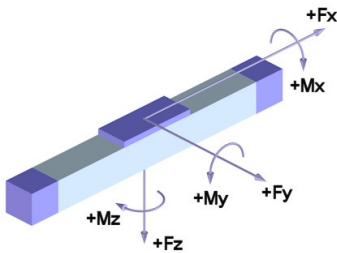

ZSS	
Forces	Dynamic [N]
F_x ^{a)}	950
F_y	1200
F_z	3000
-F_z	1500
Moments	Dynamic [Nm]
M_x	500
M_y	550 (1000)
M_z	550 (1000)

a) Maximum value (see diagram "F_x-v-Diagram")
Data in brackets refer to long carriage (265)

F_x - v - Diagram

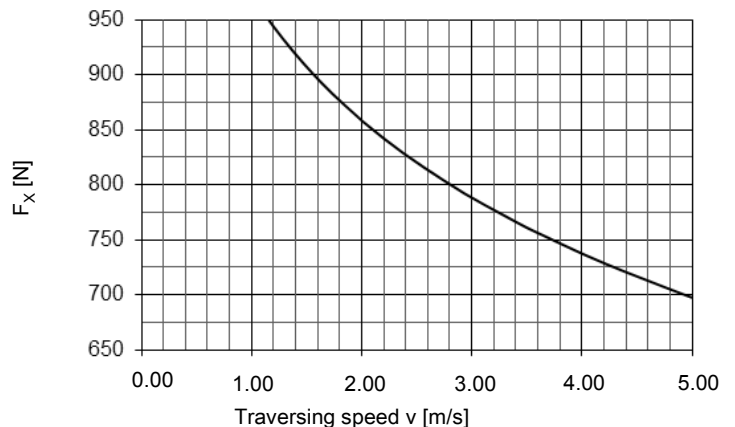

with ball screw (KGT) and double linear guide (SSS)

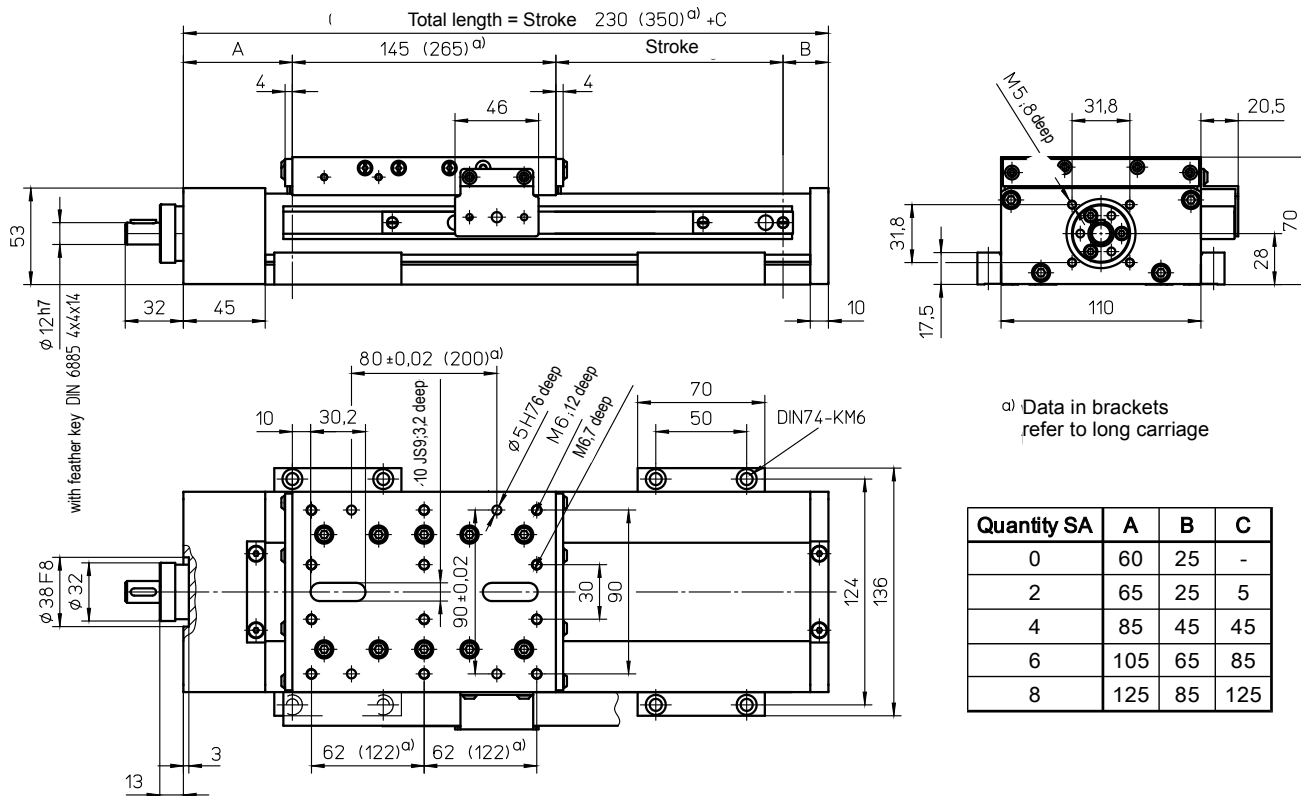

Quantity SA	A	B	C
0	60	25	-
2	65	25	5
4	85	45	45
6	105	65	85
8	125	85	125

Weights

SSS

Basic length without stroke:	4.90 kg
100 mm stroke:	0.90 kg
Entire carriage 145 mm:	2.30 kg
Entire carriage 265 mm:	3.25 kg
Max. total length:	4000 mm

Technical Data

SSS

Max. total speed:	2.00 m/s
Max. acceleration:	20 m/s ²
Repeat accuracy:	± 0.03 mm (KGT)
Idle torque:	1.0 Nm

Forces and moments

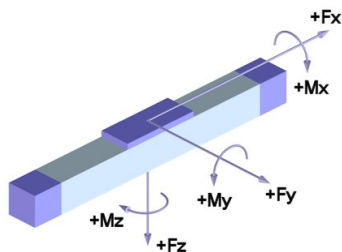

SSS	
Forces	Dynamic [N]
F _x	2000
F _y	1200
F _z	3000
-F _z	1500
Moments	Dynamic [Nm]
M _x	500
M _y	550 (1100)
M _z	550 (1100)

Data in brackets refer to long carriage (265)

Drive element

KGT

Max. rotation speed:	3000 min ⁻¹
Diameter:	16 mm
Pitch:	5 / 10 / 20 / 40 mm
Moment of inertia:	3.25 · 10 ⁻⁵ kgm ² /m

Spindle support (SA)

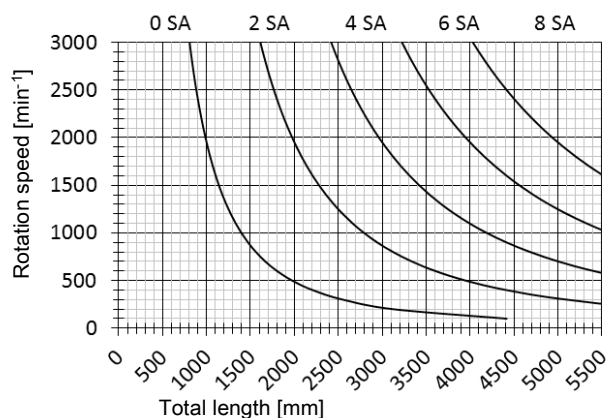

Special design: Spindle support with damping ring (extension of total length: 10 mm for every 2 SA)

with toothed belt drive and double linear guide (ZSS)

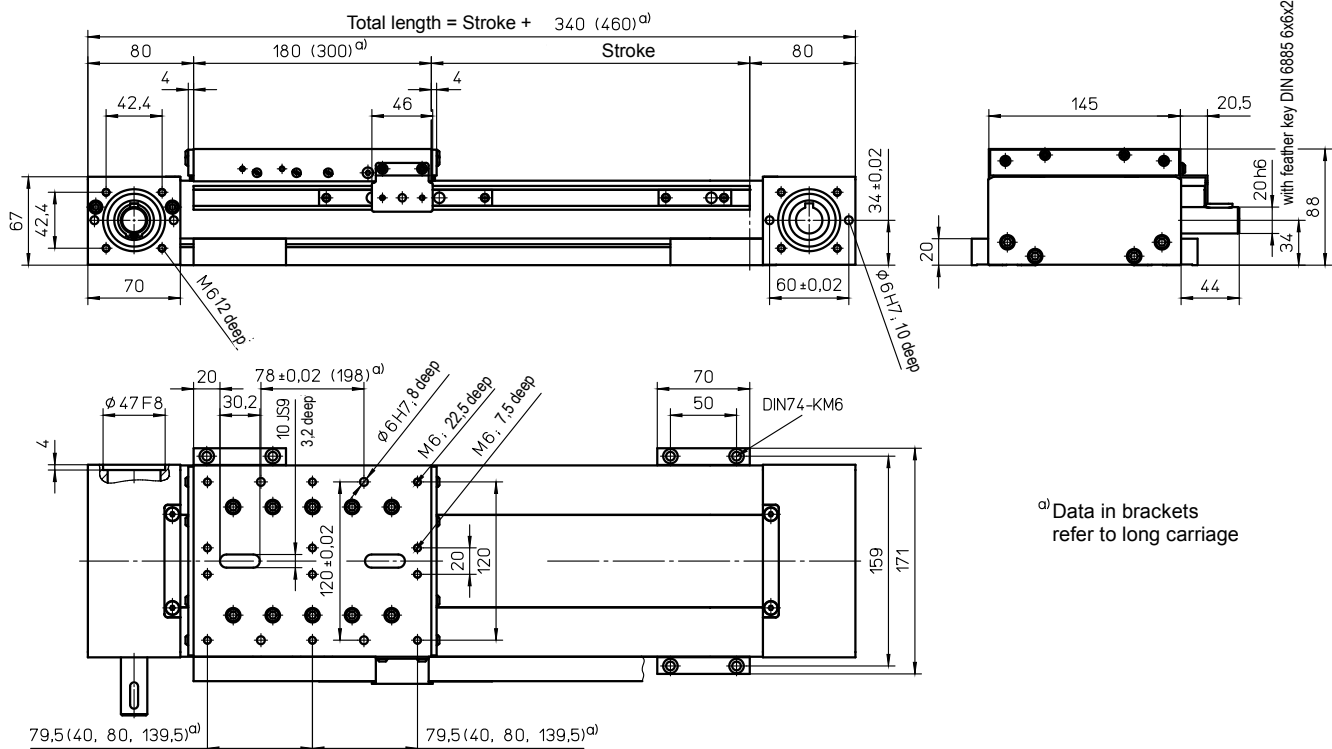

Weights	ZSS
Basic length without stroke	10.40 kg
100 mm stroke:	1.30 kg
Entire carriage 180 mm:	4.50 kg
Entire carriage 300 mm:	6.10 kg
Max. total length:	4000 mm

Technical Data	ZSS
Max. total speed:	5.00 m/s
Max. acceleration:	40 m/s ²
Repeat accuracy:	± 0.08 mm
Idle torque:	3.00 Nm
Moment of inertia:	2.85 · 10 ⁻³ kgm ²
Drive element:	Toothed belt 60 AT5-E
Stroke per revolution:	150 mm

Forces and moments

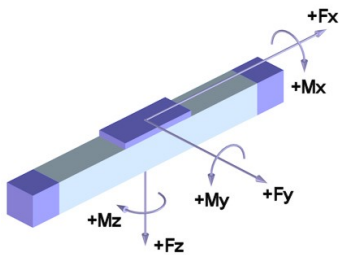

ZSS	
Forces	Dynamic [N]
F _x ^{d)}	2000
F _y	2500
F _z	5000
-F _z	3000
Moments	Dynamic [Nm]
M _x	800
M _y	1000 (1600)
M _z	1000 (1600)

Data in brackets refer to long carriage (300)

Compact module is available in two profile versions:
 Stop angle and position of guide support milled = Standard (Delta 145-C-ZSS)
 Unmachined = Alternative (Delta 145-C-ZSA)

F_x - v - Diagram

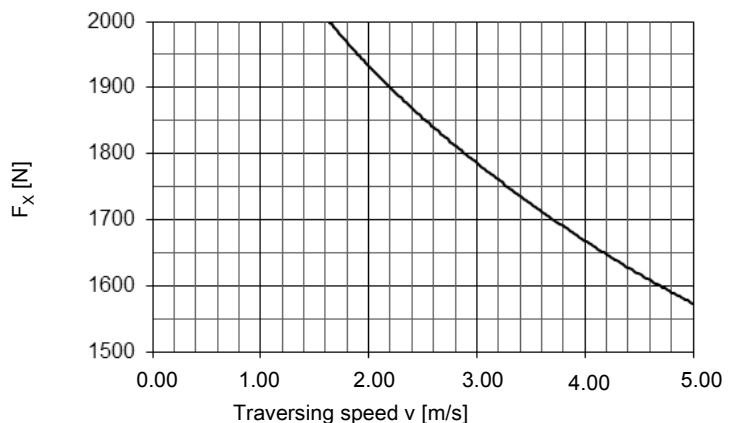

with ball screw (KGT) and double linear guide (SSS)

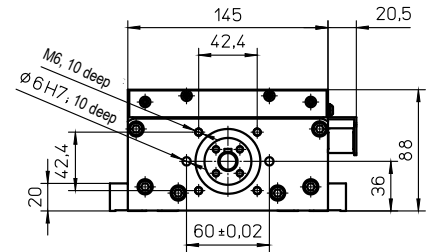
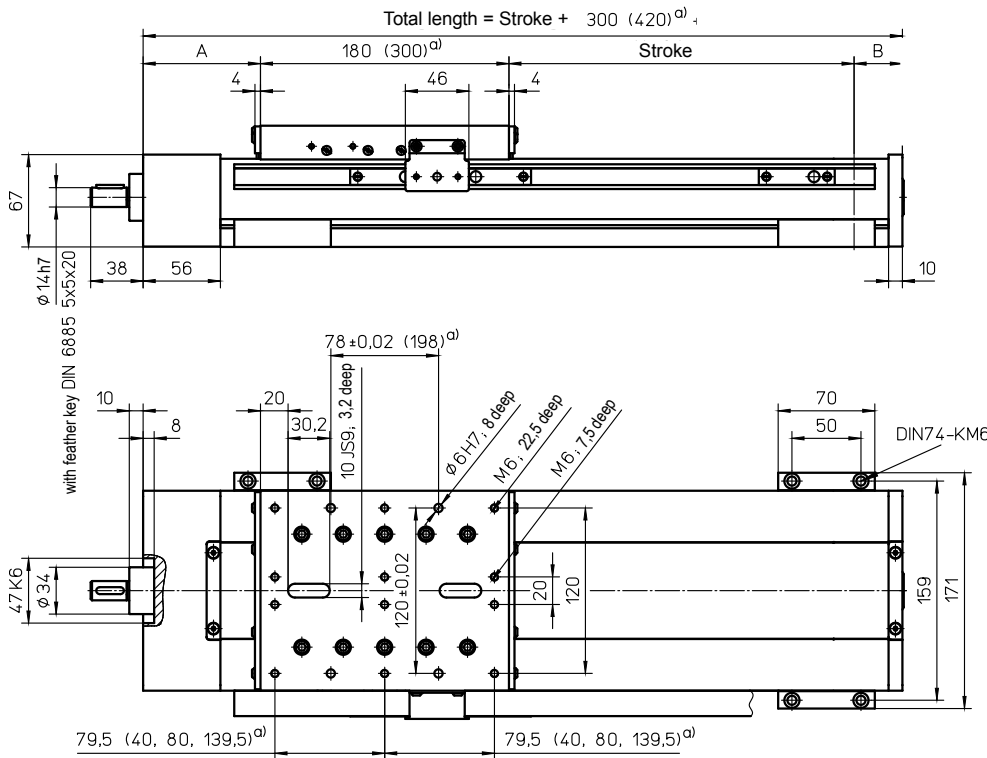

a) Data in brackets refer to long carriage

Shorter carriage L=120 on request

Quantity SA	A	B	C
0	85	35	-
2	85	35	-
4	115	65	60
6	145	95	120
8	175	125	180

Weights

SSS

Basic length without stroke:	10.30 kg
100 mm stroke:	1.50 kg
Entire carriage 180 mm:	4.90 kg
Entire carriage 300 mm:	6.50 kg
Max. total length:	4000 mm

Technical Data

SSS

Max. total speed:	2.50 m/s
Max. acceleration:	20 m/s ²
Repeat accuracy:	± 0.03 mm (KGT)
Idle torque:	1.00 Nm

Forces and Moments

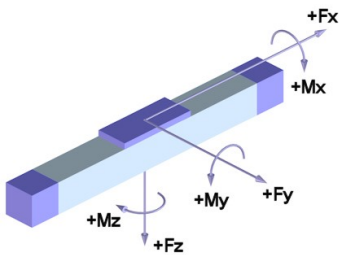

SSS	
Forces	Dynamic [N]
F _x	6000
F _y	2500
F _z	5000
-F _z	3000
Moments	Dynamic [Nm]
M _x	800
M _y	1000 (1600)
M _z	1000 (1600)

Data in brackets refer to long carriage (300)

Compact module is available in two profile versions:

Stop angle and position of guide support milled = Standard (Delta 145-C-SSS)

Unmachined = Standard (Delta 145-C-SSA)

Special design: Spindle support with damping ring (extension of total length: 10 mm for every 2 SA)

Drive element

KGT

Max. rotation speed:	3000 min ⁻¹
Diameter:	20 mm
Pitch:	5 / 10 / 20 / 50 mm
Moment of inertia:	8.50 · 10 ⁻⁵ kgm ² /m

Spindle support SA

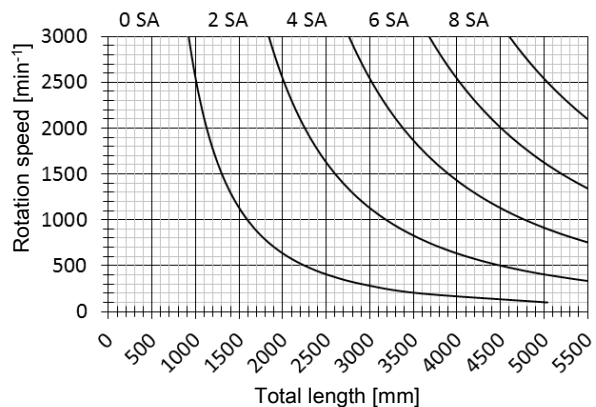

with toothed belt drive and double linear guide (ZSS)

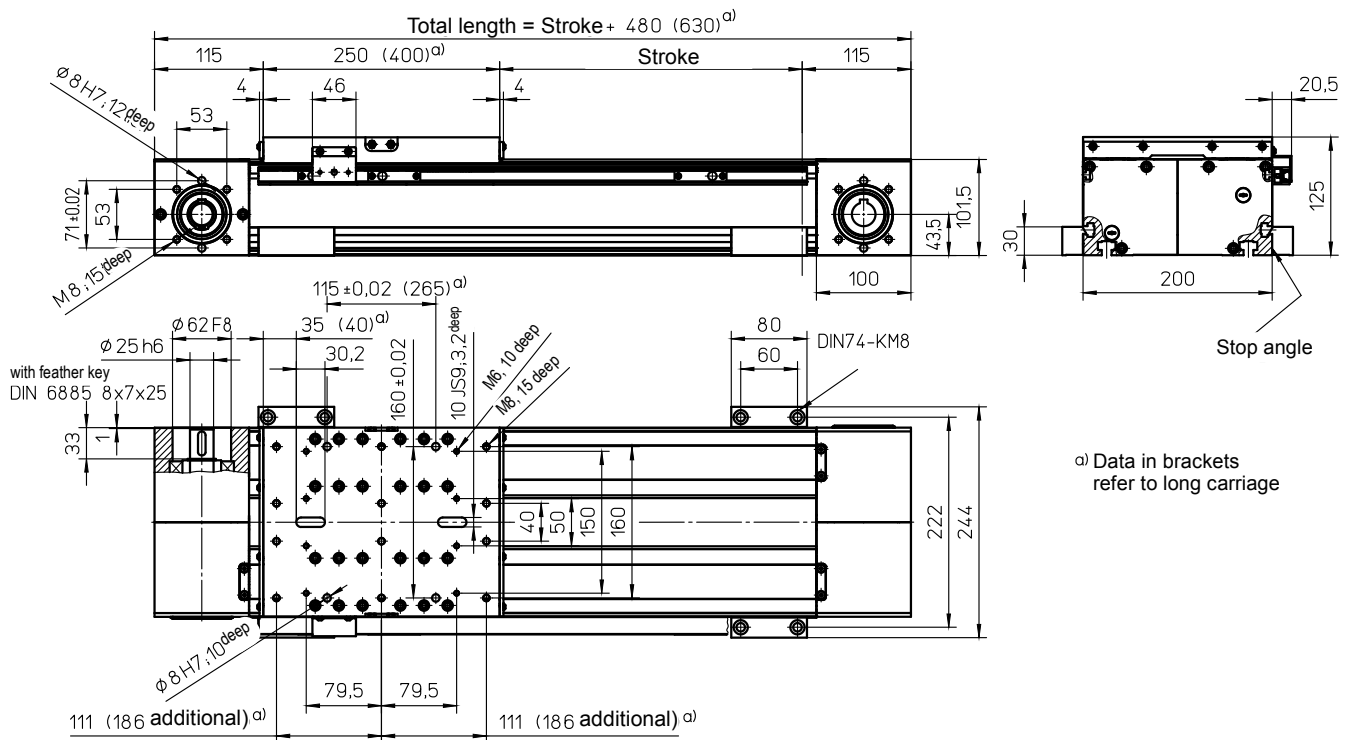

Weights

ZSS

Basic length without stroke:	25.00 kg
100 mm stroke:	2.00 kg
Entire carriage 250 mm:	8.20 kg
Entire carriage 400 mm:	10.50 kg
Max. total length:	2000 mm

Technical Data

ZSS

Max. total speed:	5.00 m/s
Max. acceleration:	60 m/s ²
Repeat accuracy:	± 0.08 mm
Idle torque:	3.80 Nm
Moment of inertia:	1.20 · 10 ⁻² kgm ²
Drive element:	Toothed belt 75 AT10
Stroke per revolution:	220 mm

Forces and moments

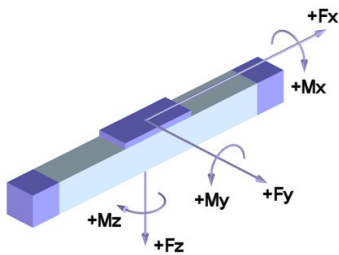

ZSS	
Forces	Dynamic [N]
F _x ^{ᵃ)}	6000
F _y	5000
F _z	8000
-F _z	5000
Moments	Dynamic [Nm]
M _x	3500
M _y	4300 (6000)
M _z	3200 (4500)

ᵃ) Maximum value (see diagram "F_x-v-Diagram")
Data in brackets refers to long carriage (400)

F_x - v - Diagram

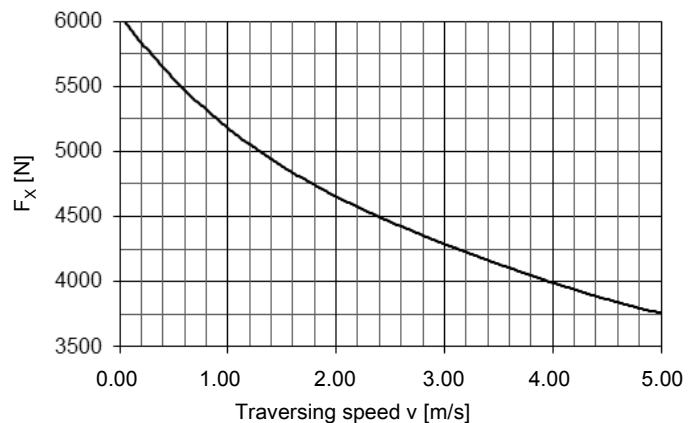

with ball screw (KGT) and double linear guide (SSS)

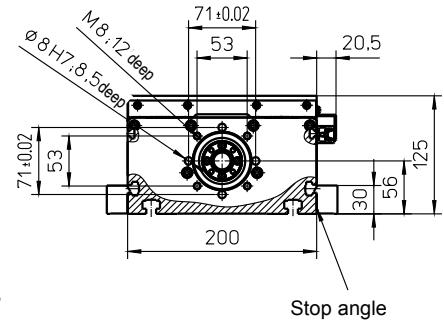
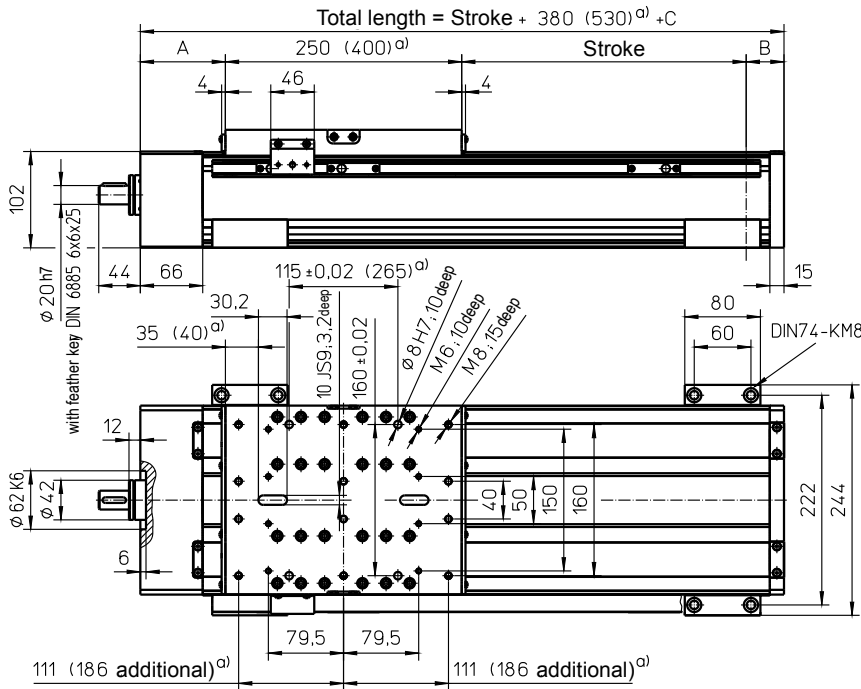

^{a)} Data in brackets refers to long carriage

Quantity SA	Version			MM		
	A	B	C	A	B	C
0	90	40	-	90	40	-
2						

"0 SA" applies for long carriage

Weights

	SSS
Basic length without stroke:	22.00 kg
100 mm stroke:	2.60 kg
Entire carriage 250 mm:	8.40 kg
Entire carriage 400 mm:	11.00 kg
Max. total length:	2000 mm

Technical Data

	SSS
Max. total speed:	3.00 m/s
Max. acceleration:	20 m/s ²
Repeat accuracy:	± 0.03 mm (KGT)
Idle torque:	2.80 Nm

Forces and moments

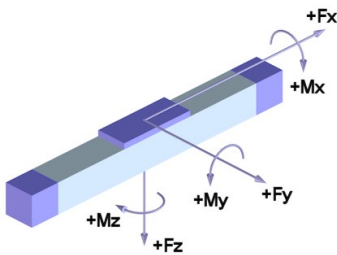

	SSS
Forces	Dynamic [N]
F_x	10000 *
F_y	5000
F_z	8000
-F_z	5000
Moments	Dynamic [Nm]
M_x	3500
M_y	4300 (6000)
M_z	3200 (4500)

Data in brackets refer to long carriage (400)

* at KGT 3240 and 3260: 8000 N

Drive element

	KGT
Max. rotation speed:	3000 min ⁻¹
Diameter:	32 mm
Pitch:	5 / 10 / 20 / 40 / 60 mm
Moment of inertia:	6.45 · 10 ⁻⁴ kgm ² /m

Spindle support (SA)

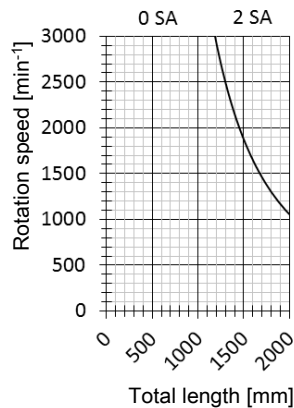

with toothed belt drive and double linear guide (ZSS)

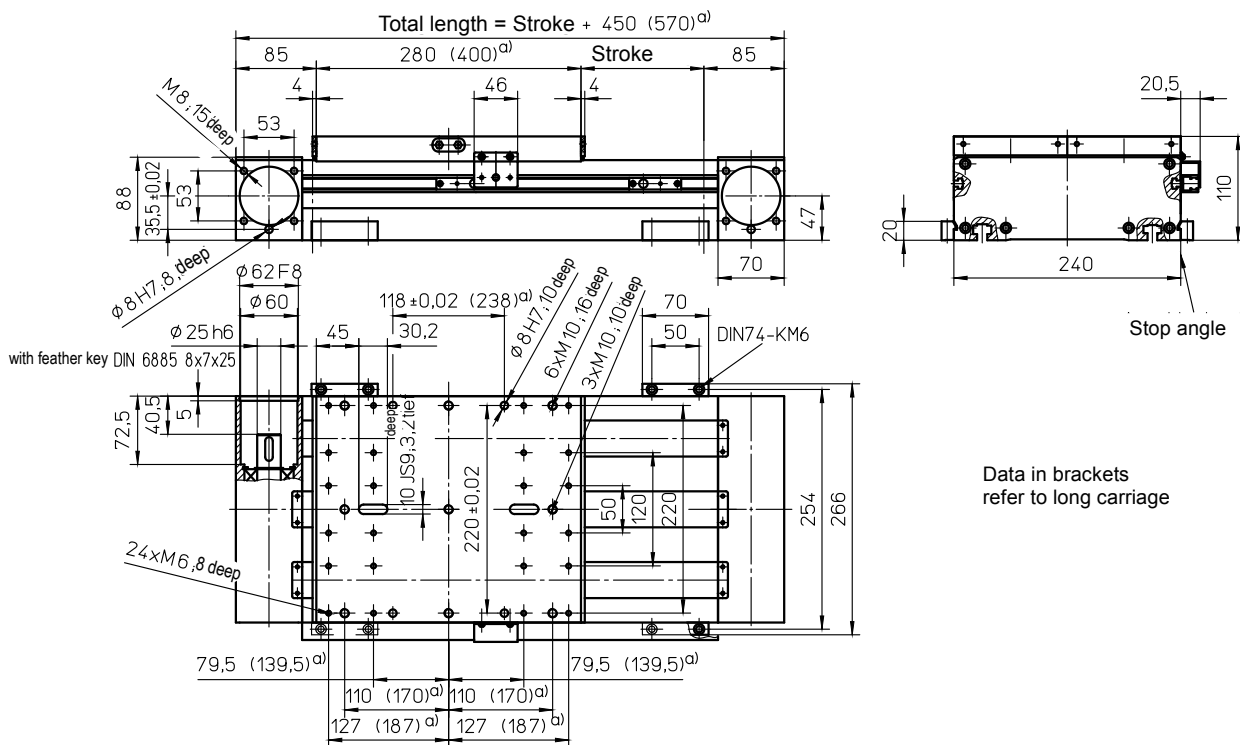

Weights

ZSS

Basic length without stroke:	27.00 kg
100 mm stroke:	3.40 kg
Entire carriage 280 mm:	9.80 kg
Entire carriage 400 mm:	14.00 kg
Max. total length:	3000 mm

Technical Data

ZSS

Max. total speed:	5.00 m/s
Max. acceleration:	60 m/s ²
Repeat accuracy:	± 0.08 mm
Idle torque:	5.50 Nm
Moment of inertia:	2.00 • 10 ⁻² kgm ²
Drive element:	Toothed belt 50 AT10-E
Stroke per revolution:	150 mm

Forces and moments

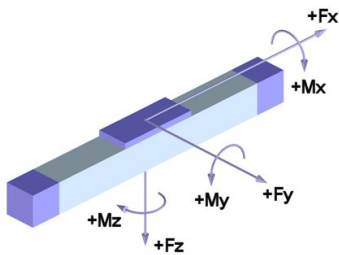

ZSS	
Forces	Dynamic [N]
F _x ^ᵃ	2500
F _y	6000
F _z	12000
-F _z	8000
Moments	Dynamic [Nm]
M _x	4500
M _y	6000 (8500)
M _z	4500 (6400)

^ᵃ Maximum value (see diagram "F_x -v-Diagram")
Data in brackets refers to long carriage (400)

F_x - v - Diagram

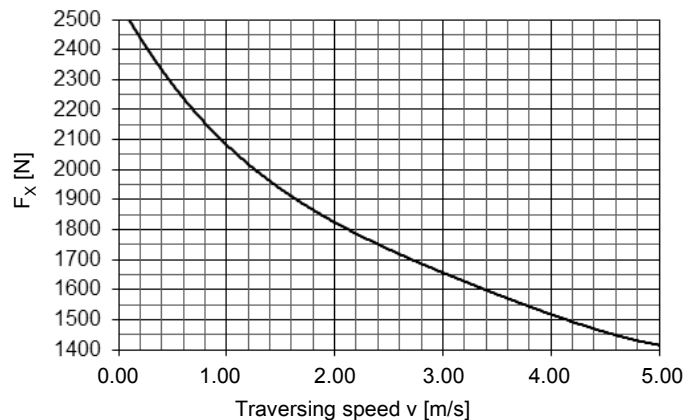

with ball screw (KGT) and double linear guide (SSS)

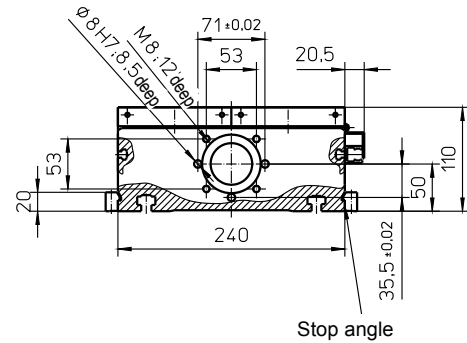
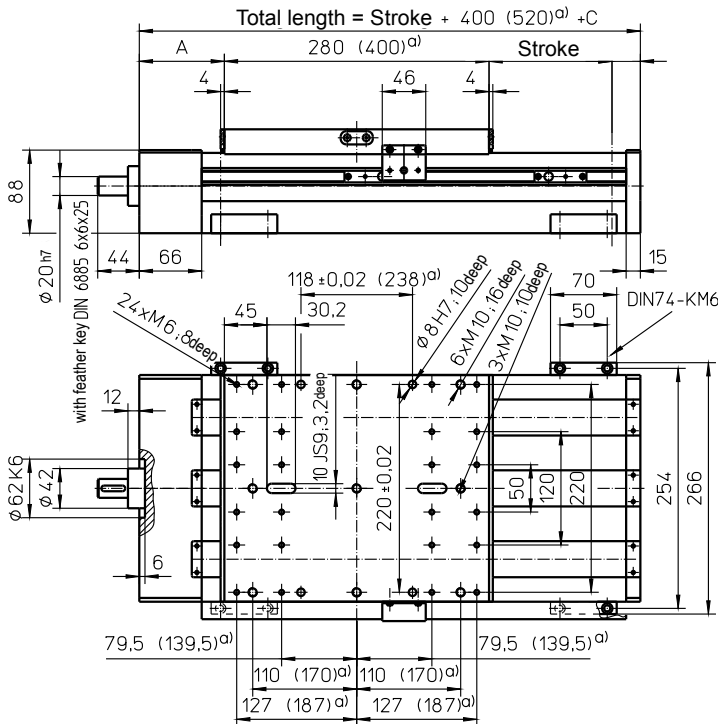

o) Data in brackets refer to long carriage

Quantity SA	Version M			Version MM		
	A	B	C	A	B	C
0	90	30	-	90	30	-
2	130	70	80	130	70	80
4	130	70	80	130	70	80

"0 SA" applies for long carriage

Weights

SSS

Basic length without stroke:	26.00 kg
100 mm stroke:	3.90 kg
Entire carriage 280 mm:	10.20 kg
Entire carriage 400 mm:	14.60 kg
Max. total length:	3000 mm

Technical Data

SSS

Max. total speed:	3.00 m/s
Max. acceleration:	20 m/s ²
Repeat accuracy:	± 0.03 mm (KGT)
Idle torque:	2.80 Nm

Forces and moments

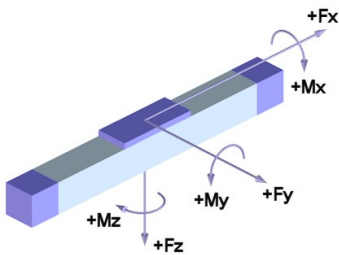

SSS	
Forces	Dynamic [N]
F _x	12000
F _y	6000
F _z	12000
-F _z	8000
Moments	Dynamic [Nm]
M _x	4500
M _y	6000 (8500)
M _z	4500 (6400)

Data in brackets refer to long carriage (400)

Drive element

KGT

Max. rotation speed:	3000 min ⁻¹
Diameter:	32 mm
Pitch:	5 / 10 / 20 / 40 / 60 mm
Moment of inertia:	6.45 · 10 ⁻⁴ kgm ² /m

Spindle support (SA)

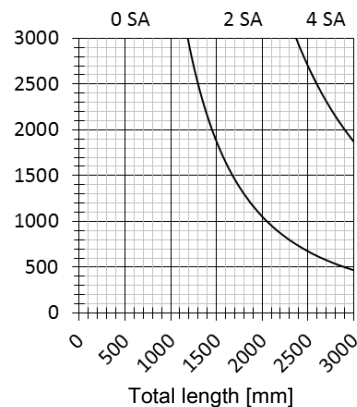

with toothed belt drive and double linear guide (ZSS)

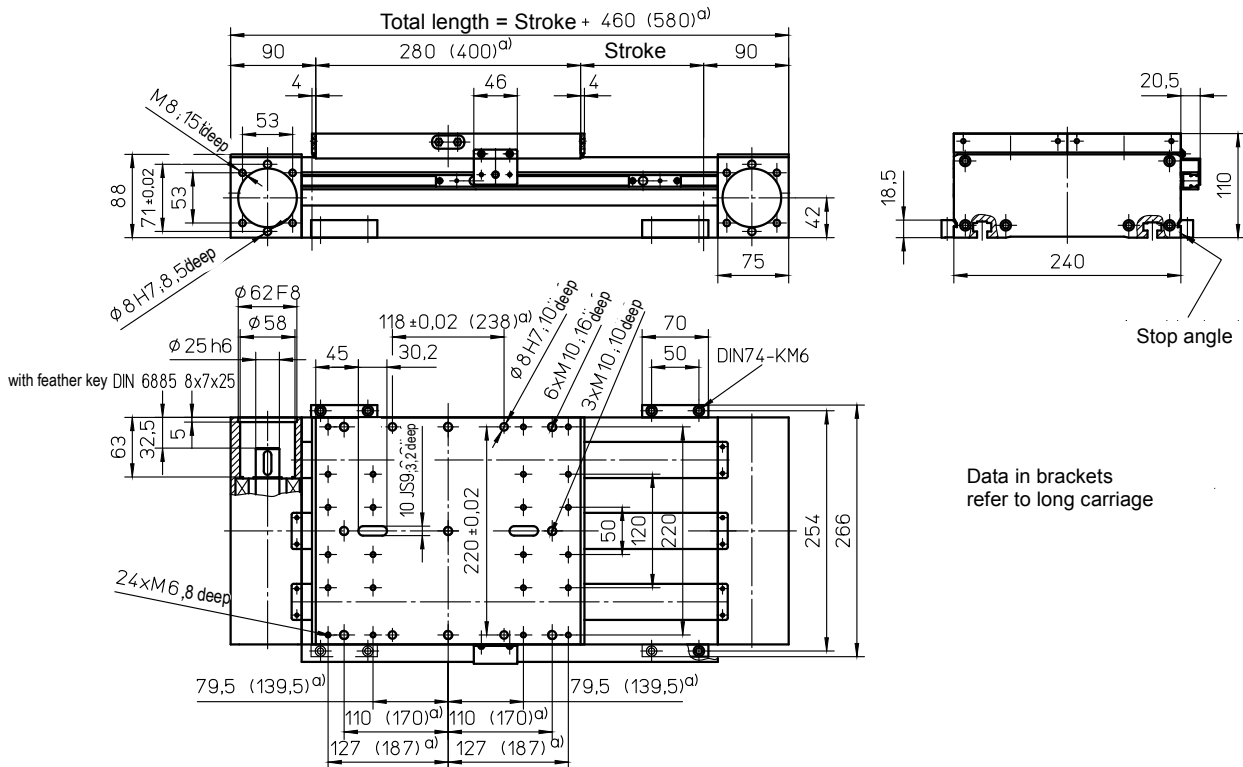

Data in brackets refer to long carriage

Weights

ZSS

Basic length without stroke:	25.50 kg
100 mm stroke:	2.75 kg
Entire carriage 280 mm:	9.80 kg
Entire carriage 400 mm:	14.00 kg
Max. total length:	8000 mm

Technical Data

ZSS

Max. total speed:	5.00 m/s
Max. acceleration:	60 m/s ²
Repeat accuracy:	± 0.08 mm
Idle torque:	5.50 Nm
Moment of inertia:	2.60 · 10 ⁻² kgm ²
Drive element:	Toothed belt 60 ATL10
Stroke per revolution:	180 mm

Forces and moments

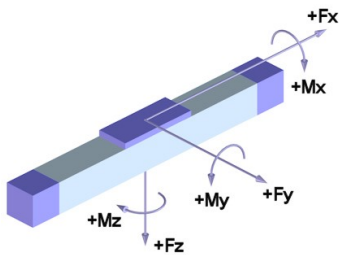

ZSS	
Forces	Dynamic [N]
F _x ^{d)}	3800
F _y	6000
F _z	12000
-F _z	8000
Moments	Dynamic [Nm]
M _x	4500
M _y	6000 (8500)
M _z	4500 (6400)

^{d)} Maximum value (see diagram "F_x-v-Diagram")
Data in brackets refer to long carriage (400)

F_x - v - Diagram

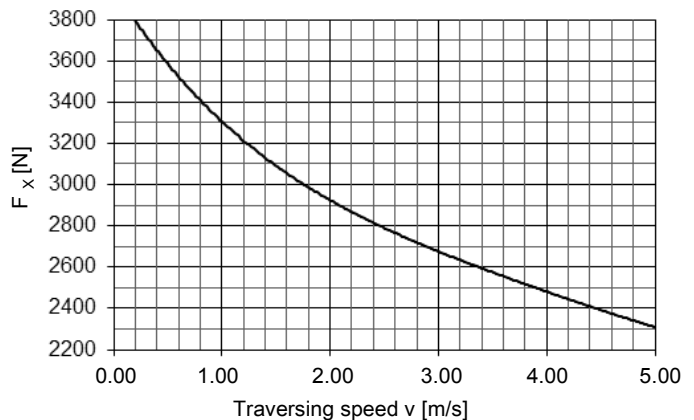

with ball screw (KGT) and double linear guide (SSS)

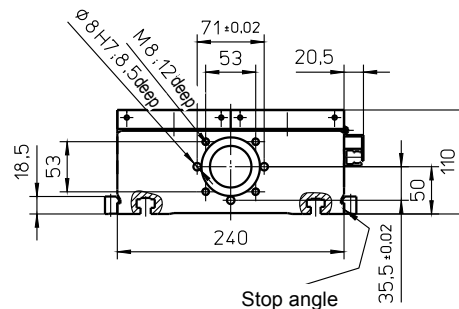
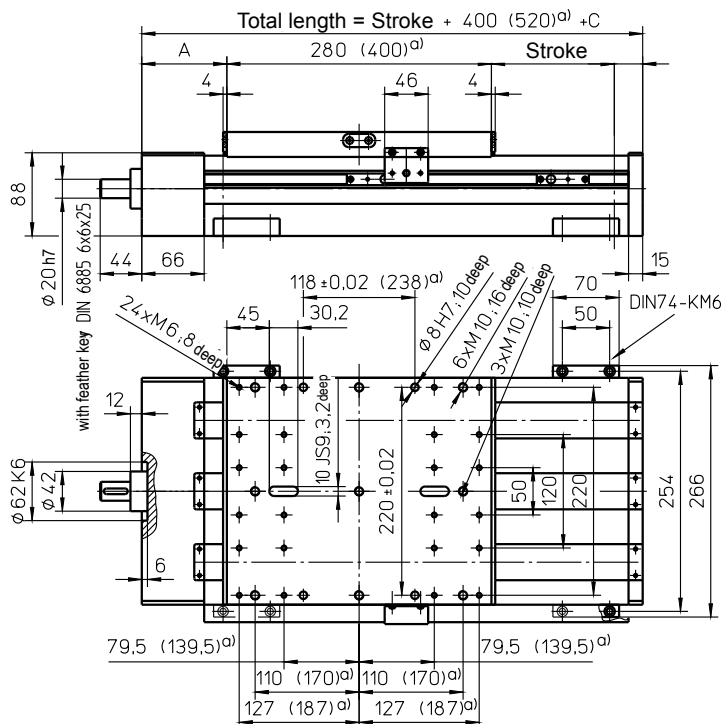

o) Data in brackets refer to long carriage

Quantity SA	Version			Version		
	M			MM		
0	A	B	C	A	B	C
2	90	30	-	90	30	-
4	130	70	80	130	70	80

"0 SA" applies for long carriage

Weights

SSS

Basic length without stroke:	24.20 kg
100 mm stroke:	3.25 kg
Entire carriage 280 mm:	10.20 kg
Entire carriage 400 mm:	14.60 kg
Max. total length:	5800 mm

Technical Data

SSS

Max. total speed:	3.00 m/s
Max. acceleration:	20 m/s ²
Repeat accuracy:	± 0.03 mm (KGT)
Idle torque:	2.80 Nm

Forces and moments

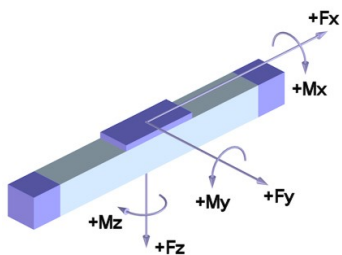

	SSS
Forces	Dynamic [N]
F_x	12000 *
F_y	6000
F_z	12000
-F_z	8000
Moments	Dynamic [Nm]
M_x	4500
M_y	6000 (8500)
M_z	4500 (6400)

Data in brackets refer to long carriage (400)

* at KGT3240 and 3260: 8000 N

Drive element

KGT

Max. rotation speed:	3000 min ⁻¹
Diameter:	32 mm
Pitch:	5 / 10 / 20 / 40 / 60 mm
Moment of inertia:	6.45 · 10 ⁻⁴ kgm ² /m

Spindle support (SA)

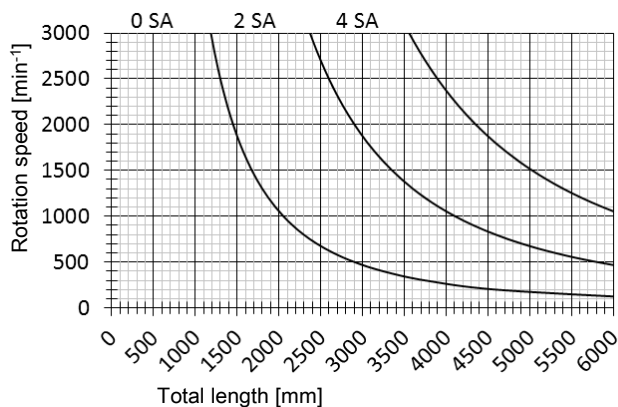

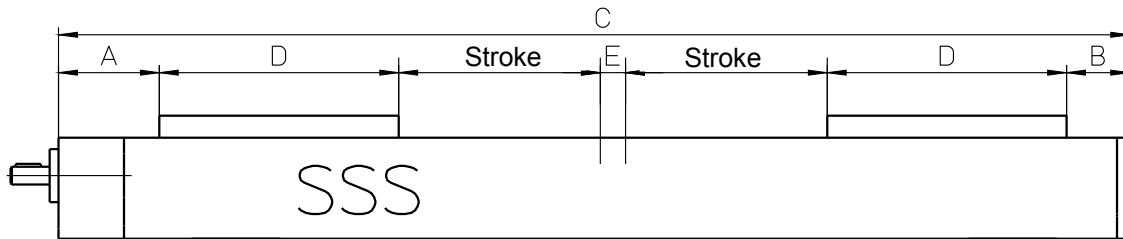

Unit size	A [mm]	B [mm]	Total length C [mm]	D [mm]	E [mm]	Screw drive *
Delta 110-C-SSS	60	25	2 x stroke + 375 (615) ^{a)} + E 80 mm extension for every 4 SA	145 (265) ^{a)}	min. 20 without SA	KGT 1605
Delta 145-C-SSS	85	35	2 x Verfahrweg + 480 (720) ^{a)} + E 120 mm extension for every 4 SA	180 (300) ^{a)}	min. 20 without SA	KGT 2005

For detailed measurements, see main dimensions sheet for respective size (version).

* Design only available with pitch 50

a) Data in brackets apply to long carriage

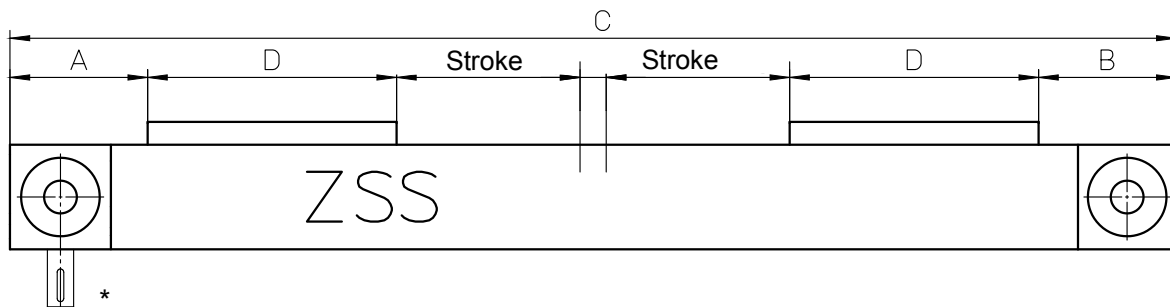

Unit size	A [mm]	B [mm]	Total length C [mm]	D [mm]	E [mm]
Delta 110-ZSS *	77,5	77,5	2 x stroke + 445 (685) ^{a)} + E	145 (265) ^{a)}	min. 20
Delta 145-ZSS on request	80	80	2 x stroke + 520 (760) ^{a)} + E	180 (300) ^{a)}	min. 25

For detailed measurements, see main dimensions sheet for respective size (version).

a) Data in brackets apply to long carriage

* Drive shaft downward

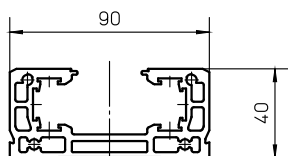

Profile Delta 90

Specific mass [kg/m]	3.36
Surface measure [mm ²]	1206
Geometrical moment of inertia I _y [mm ⁴]	223758
Geometrical moment of inertia I _z [mm ⁴]	1203307
Section modulus W _y [mm ³]	10038
Section modulus W _z [mm ³]	26740

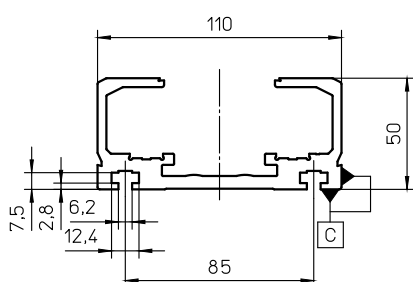

Profil Delta 110-C

Specific mass [kg/m]	4,16
Surface measure [mm ²]	1540
Geometrical moment of inertia I _y [mm ⁴]	431083
Geometrical moment of inertia I _z [mm ⁴]	2400513
Section modulus W _y [mm ³]	13230
Section modulus W _z [mm ³]	43638

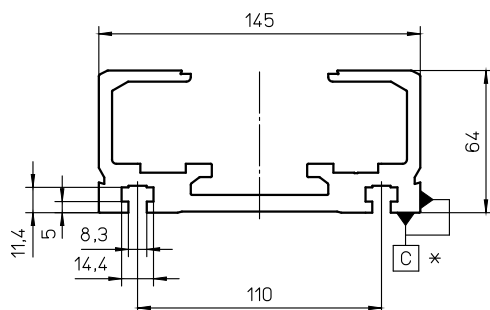

Profile Delta 145-C

Specific mass [kg/m]	7,6
Surface measure [mm ²]	2814
Geometrical moment of inertia I _y [mm ⁴]	1222896
Geometrical moment of inertia I _z [mm ⁴]	7494306
Section modulus W _y [mm ³]	29324
Section modulus W _z [mm ³]	103345

* Valid for version with machined profile.

C: Stop angle standard page C

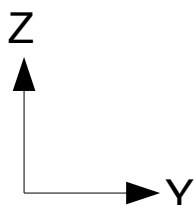

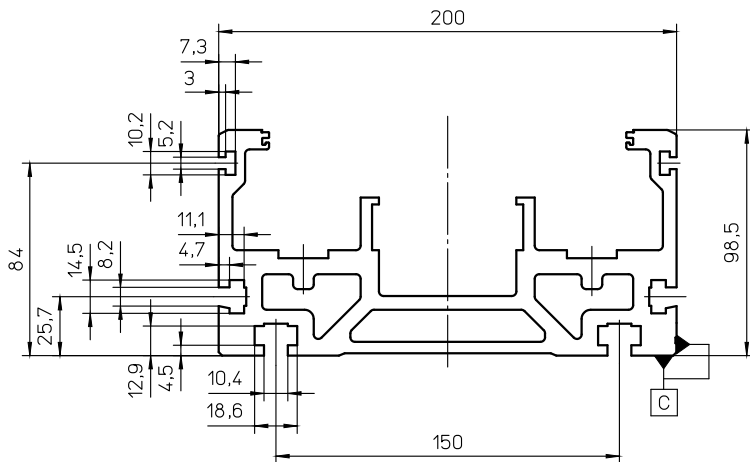

Profile Delta 200

Specific mass [kg/m]	15.4
Surface measure [mm ²]	5705
Geometrical moment of inertia I _y [mm ⁴]	3774514
Geometrical moment of inertia I _z [mm ⁴]	27532601
Section modulus W _y [mm ³]	57567
Section modulus W _z [mm ³]	274653

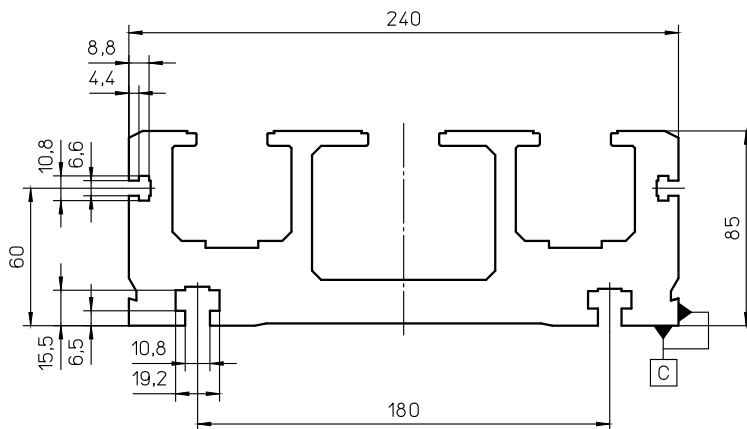

Profile Delta 240

Specific mass [kg/m]	27.2
Surface measure [mm ²]	10074
Geometrical moment of inertia I _y [mm ⁴]	6382473
Geometrical moment of inertia I _z [mm ⁴]	61720897
Section modulus W _y [mm ³]	119554
Section modulus W _z [mm ³]	511233

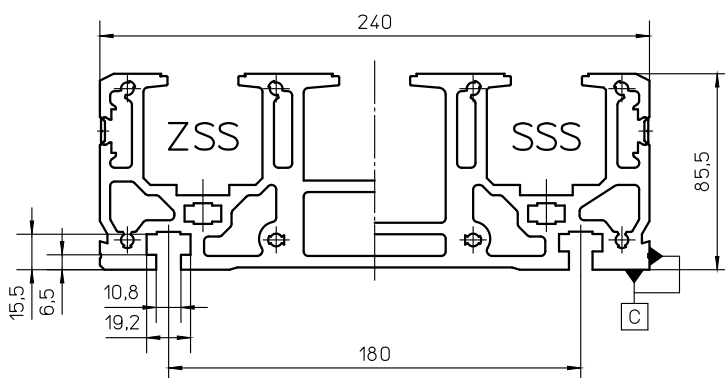

Profil Delta 240-C

ZSS

Specific mass [kg/m]	18,5
Surface measure [mm ²]	6849
Geometrical moment of inertia I _y [mm ⁴]	4852964
Geometrical moment of inertia I _z [mm ⁴]	38448444
Section modulus W _y [mm ³]	97499
Section modulus W _z [mm ³]	320403

SSS

Specific mass [kg/m]	18,8
Surface measure [mm ²]	6962
Geometrical moment of inertia I _y [mm ⁴]	4985287
Geometrical moment of inertia I _z [mm ⁴]	39550055
Section modulus W _y [mm ³]	98152
Section modulus W _z [mm ³]	329583

: Stop angle standard page C

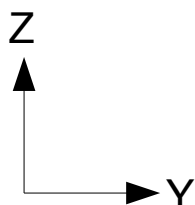

NS 1 / 2 / 4 / 6 / 22 / 23

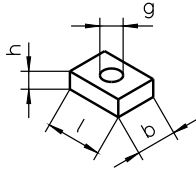

NS 4.1 / 10

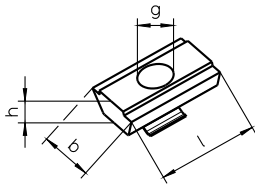

RM 2 / 4 / 6

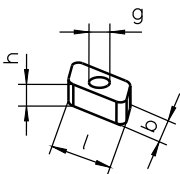

Linear drive	Page *	NS	ID No.	l [mm]	b [mm]	h [mm]	g
Delta 110-C	E	23	28914	18	12	4,5	M6
		22	27352	18	12	4,5	M5
		RM2	15370	10	6	4	M4
Delta 145-C	E	4	10559	18	14	6	M8
		4.1	16552	20	13	6	M8
		10	16499	20	13	6	M6
		RM4	15371	13	8	6	M5
Delta 200	E	6	10561	25	18	8	M10
		RM6	15372	18	10	8	M6
	C and D below	4	10559	18	14	6	M8
		4.1	16552	20	13	6	M8
		10	16499	20	13	6	M6
		RM4	15371	13	8	6	M5
	C and D below	1	10556	12	10	4	M4
2		10557	16	10	4	M5	
Delta 240	E	6	10561	25	18	8	M10
		RM6	15372	18	10	8	M6
	C and D	1	10556	12	10	4	M4
		2	10557	16	10	4	M5
		RM2	15370	10	6	4	M4
Delta 240-C	E	6	10561	25	18	8	M10
		RM6	15372	18	10	8	M6

BL 1..4 / 8 / 10

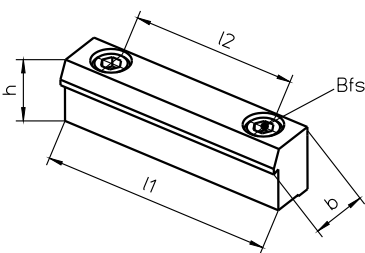

Linear drive	BL	ID No.	l1 [mm]	l2 [mm]	b [mm]	h [mm]	Bfs
Delta 90	8	18447	70	50	15	13.5	M6
Delta 110-C	1.1	13224	49	30	15	17.5	M6
	1	10552	70	50	15	17.5	M6
Delta 145-C	2	10553	70	50	15	20	M6
Delta 200	3	10554	80	60	25	30	M8
Delta 240	4	10555	70	50	16	20	M6
Delta 240-C	10	17326	70	50	15	18.5	M6

* For further information on pages C..E, see catalogue page Z1
Bfs = Mounting screw DIN 912 / ISO 4762

Example: **Delta** 145-C-ZSS-50 AT5-E-110-1000-1340-AK-AZ1-1

Product	
Unit size (version*)	
Drive	
Z = Toothed belt drive 0 = Without drive	
Guide system	
S = Rail guide R = Roller guide	
Model	
S = Standard ; A = Alternative (profile unmachined)	
Drive specifications	
Width and type of toothed belt	
Stroke per revolution	
Stroke	
Total length	
Cover	
AK = Cover band	
Accessories	
BL = Mounting bracket	
EMS / EMB = Mechanical limit switch (S = Siemens, B = Balluff) fitted	
EO2 / EO10 = Inductive limit switch NC with 2m / 10m cable fitted	
ES2 / ES10 = Inductive limit switch NO with 2m / 10m cable fitted	
NS 1 .. 21 = Sliding block ① .. ⑩ (see Table on page D16)	
AZ1 = Drive shaft short, mounting side C	
AZ2 = Drive shaft short, mounting side D	
AZ6 = Drive shaft long, mounting side C and D	
AZX = Integrated drive shaft (standard, not Delta 110-C and 145-C)	
Further arrangements for drive shaft, see page Z1	
Special design	
0 = Standard	
1 = Special (add specification description)	

Further accessories (separate position)

MGK = Motor mounting and coupling (according to dimension sheet)

URT = Deflection belt drive (according to dimension sheet)

* e.g. Delta 240-ZSS or Delta 240-C-ZSS

Example: Delta 145-C-SSS-M-2510-1000-1360-2SA-2ES2-0

Product _____

Unit size (version*) _____

Drive _____

S = Spindle

0 = Without drive

Guide system _____

S = Rail guide

R = Roller guide

Model _____

S = Standard ; A = Alternative (profile unmachined)

Type of drive _____

M = Single nut (ball screw)

MM = Double nut (ball screw)

(TR = Trapezoidal screw - optional)

Drive specifications _____

Diameter and pitch (ball screw)

(Diameter x pitch (trapezoidal screw) - optional)

Stroke _____

Total length _____

Spindle support (SA) _____

(quantity)

Accessories _____

BL = Mounting bracket

EMS / EMB = Mechanical limit switch (S = Siemens, B = Balluff) fitted

EO2 / EO10 = Inductive limit switch NC with 2m / 10m cable fitted

ES2 / ES10 = Inductive limit switch NO with 2m / 10m cable fitted

NS ① .. ⑩ = Sliding block ① .. ⑩ (see Table on **page D16**)

Special design _____

0 = Standard

1 = Special (add specification description)

Further accessories (separate position)

MGK = Motor mounting and coupling (according to dimension sheet)

URT = Deflection belt drive (according to dimension sheet)

For mounting of limit switches and lubrication points, see **page Z1**

Cover band comes as standard for screw drive

Further drives available on request:

MK or TK (= single nut made of plastic), KK (= double nut made of plastic)

* e.g. Delta 240-SSS or Delta 240-C-SSS



Chapter Z

Accessories

Ordering code for limit switch positions, limit switch type (EN),
lubrication ports and drive shafts (AZ) and wiper versions

Limit switch position

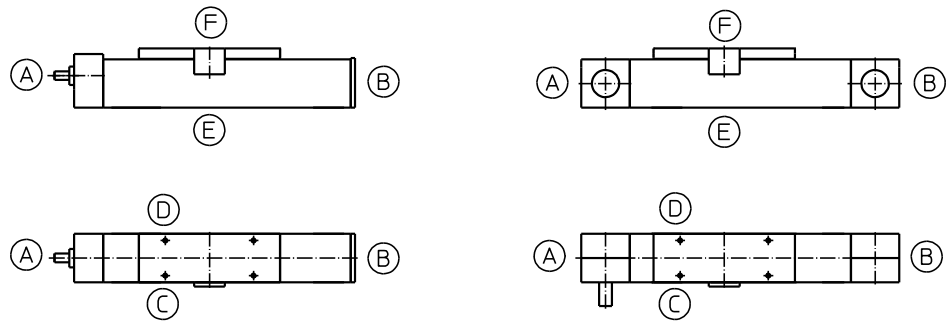

Limit switch types (EN)

- EO2 = Inductive proximity switch “Normally Closed” with 2 m cable (L 408.2115.25)
- EO10 = Inductive proximity switch “Normally Closed” with 10 m cable (L 408.2116.25)
- ES2 = Inductive proximity switch “Normally Open” with 10 m cable (L 408.2118.25)
- ES10 = Inductive proximity switch “Normally Open” with 2 m cable (L 408.2117.25)
- EMS / EMB = Mechanical limit switch “normally closed” (S = Siemens, B = Balluff; without cable)

Insofar as there are no other specifications provided, the limit switches are fitted as follows (standard):

1. Switch: **EO2 NC** with 2 m cable on page C, pos. A, cable exit at A
Switching point = Mechanical end position
2. Switch: **EO2 NC** with 2 m cable on page C, pos. B, cable exit at B
Switching point = Mechanical end position
3. Switch: **ES2 NO** with 2 m cable on page C, pos. A, cable exit at A
Switching point = Directly beside first switch (as reference)

Lubrication ports

Standard Beta, Delta-C and Alpha: Lubricating nipple M8x1, page C + D
(exception: Delta = M6; Beta 40, Beta 70-C-ARS-ASS = drive in lubrication nipple)

Drive shafts (AZ)

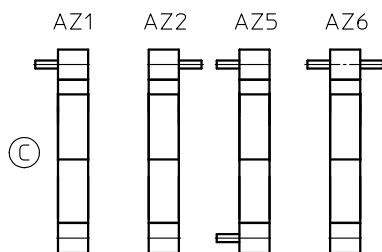

Wiper versions

(Design is based on carriage plate)

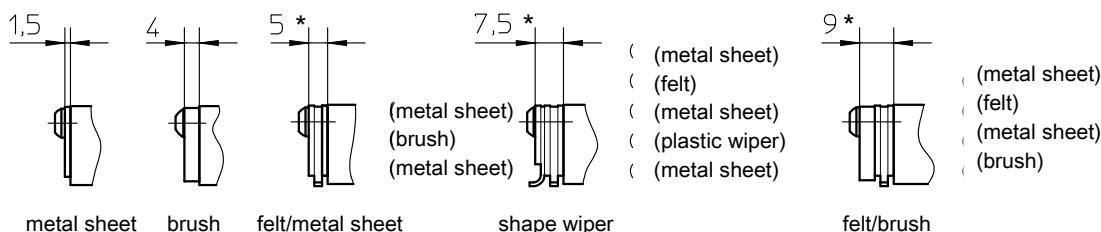

* Bei Beta 165(-C)
und Beta 180(-C)
+ 2 mm

Deflection belt drive mounting (URT)

URT can be turned 90° when mounted

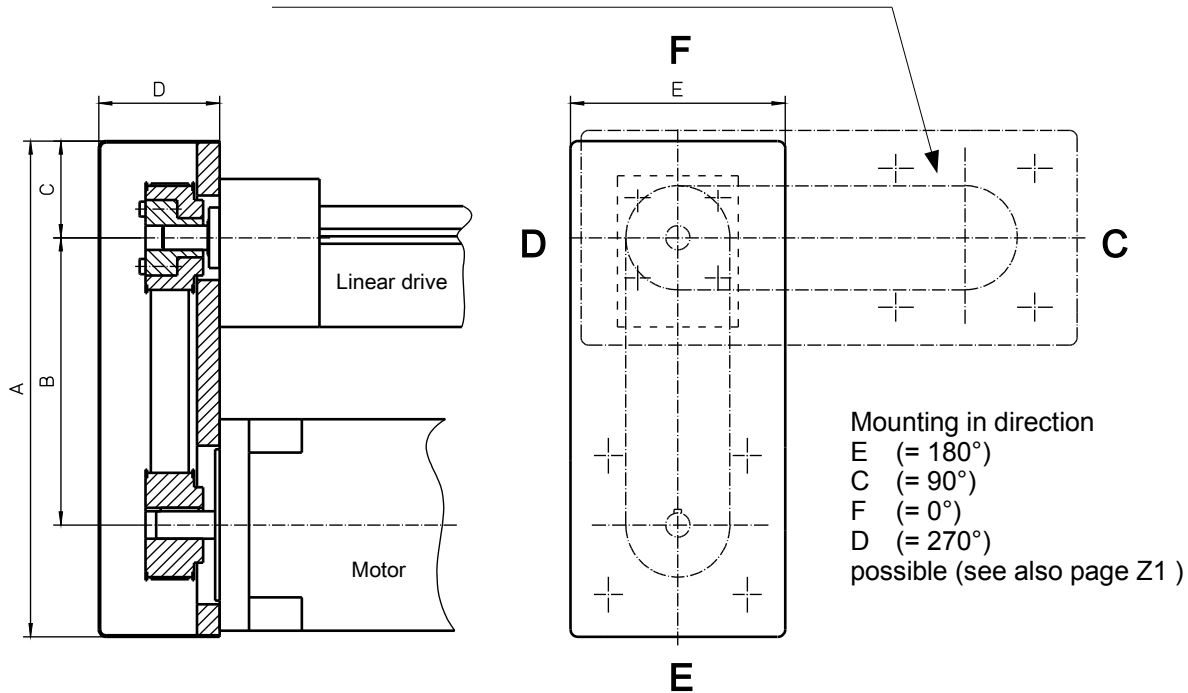

Linear drive version			URT version	A	B*	C	D	E
Beta 40 Beta 50-C	Delta 90 Delta 110		URT 1	195	105 ±10	41	45	90
Beta 60 Beta 70-C	Delta 145-C	Alpha 15-B	URT 2	238	120 ±10	46	52	102
Beta 80(-C) Beta 100-D Beta 110 Beta 120-C Beta 140(-C) Beta 165(-C) Beta 180(-C)	Delta 200 Delta 240	Alpha 20-B Alpha 30-B Alpha 35-B	URT 3	328	190 ±10	64	80	142

* Centre distance B: depending on ratio and toothed belt

Possible gear ratios:

$i = 1:1$
 $i = 2:1$
 $i = 3:1^{**}$

Note: Depending on the motor shaft diameter and necessary drive moment, all ratios may not be possible

** maximum possible motor shaft diameter with shaft without feather key:

URT 1: not possible
 URT 2: 11
 URT 3: 15

Motor mounting shown in direction E (= 180°) (dashed C (= 90°))

Bevel gear mounting (KRG)

Unit size	Gear types	Version	Ratio	b	l2	l3	l4	n	s	t
Beta 40	V065	E0, K0	1:1 ... 3:1	65	11	53	95	42	M6	54
Beta 50-C	V065	E0, K0	1:1 ... 3:1	65	11	53	95	42	M6	54
Beta 60	V065	E0, K0	1:1 ... 3:1	65	16	58	100	42	M6	54
Beta 60-SGV	V065	E0, K0	1:1 ... 3:1	65	16	58	100	42	M6	54
Beta 70-C	V065	E0, K0	1:1 ... 3:1	65	16	58	100	42	M6	54
Beta 80	V090	E0, K0	1:1 ... 6:1	90	20	75	130	55	M8	75
Beta 100-D	V090	E0, K0	1:1 ... 6:1	90	20	75	130	55	M8	75
Beta 110	V090	E0, K0	1:1 ... 6:1	90	20	75	130	55	M8	75
Beta 110-C-SGV	V120	E0, K0	1:1 ... 6:1	120	30	102	174	75	M10	100
Beta 120-C	V120	E0, K0	1:1 ... 6:1	120	30	102	174	75	M10	100
Beta 140(-C)	V090	E0, K0	1:1 ... 6:1	90	20	75	130	55	M8	75
Beta 165(-C)	V120	E0, K0	1:1 ... 6:1	120	30	102	174	75	M10	100
Beta 180(-C)	V120	E0, K0	1:1 ... 6:1	120	30	102	174	75	M10	100
Delta 90	V065	E0, K0	1:1 ... 3:1	65	16	58	100	42	M6	54
Delta 110	V065	E0, K0	1:1 ... 3:1	65	18	58	100	42	M6	54
Delta 145-C	V090	B0,C0,G0,H0	1:1 ... 6:1	90	94	149	204	55	M8	75
Delta 200	V120	B0,C0,G0,H0	1:1 ... 6:1	120	112	184	256	75	M10	100
Delta 240(-C)	V120	B0,C0,G0,H0	1:1 ... 6:1	120	112	184	256	75	M10	100
Alpha 15-B-155	V065	E0, K0	1:1 ... 3:1	65	16	58	100	42	M6	54
Alpha 20-B-225	V090	E0, K0	1:1 ... 6:1	90	20	75	130	55	M8	75
Alpha 30-B-325	V090	E0, K0	1:1 ... 6:1	90	20	75	130	55	M8	75
Alpha 35-B-455	V120	E0, K0	1:1 ... 6:1	120	30	102	174	75	M10	100

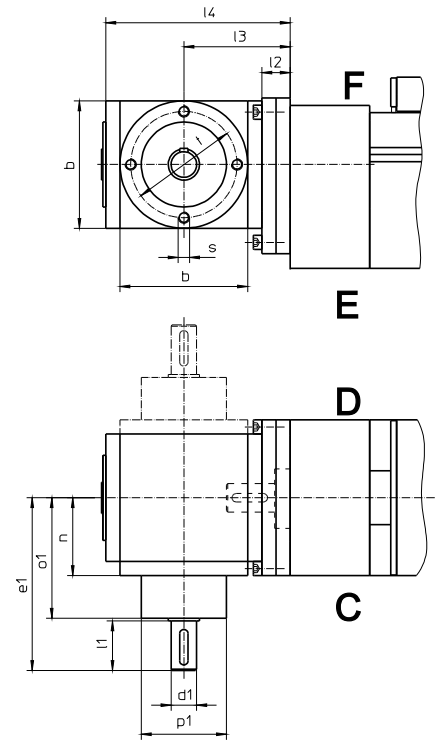

Motor mounting side "C", "D", "E" or "F" (see also page Z1)

Ratio	1:1 – 2:1					3:1					4:1					5:1 – 6:1					
	d1	l1	e1	o1	p1	d1	l1	e1	o1	p1	d1	l1	e1	o1	p1	d1	l1	e1	o1	p1	
Beta 40	12	26	100	72	44	12	26	100	72	44											
Beta 50-C	12	26	100	72	44	12	26	100	72	44											
Beta 60	12	26	100	72	44	12	26	100	72	44											
Beta 60-SGV	12	26	100	72	44	12	26	100	72	44											
Beta 70-C	12	26	100	72	44	12	26	100	72	44											
Beta 80	18	35	122	85	60	12	35	122	85	60	12	35	132	95	60	12	35	132	95	60	
Beta 100-D	18	35	122	85	60	12	35	122	85	60	12	35	132	95	60	12	35	132	95	60	
Beta 110	18	35	122	85	60	12	35	122	85	60	12	35	132	95	60	12	35	132	95	60	
Beta 110-C-SGV	25	45	162	115	80	20	45	162	115	80	20	45	172	125	80	15	35	162	125	70	
Beta 120-C	25	45	162	115	80	20	45	162	115	80	20	45	172	125	80	15	35	162	125	70	
Beta 140(-C)	18	35	122	85	60	12	35	122	85	60	12	35	132	95	60	12	35	132	95	60	
Beta 165(-C)	25	45	162	115	80	20	45	162	115	80	20	45	172	125	80	15	35	162	125	70	
Beta 180(-C)	25	45	162	115	80	20	45	162	115	80	20	45	172	125	80	15	35	162	125	70	
Delta 90	12	26	100	72	44	12	26	100	72	44											
Delta 110-C	12	26	100	72	44	12	26	100	72	44											
Delta 145-C	18	35	122	85	60	12	35	122	85	60	12	35	132	95	60	12	35	132	95	60	
Delta 200	25	45	162	115	80	20	45	162	115	80	20	45	172	125	80	15	35	162	125	70	
Delta 240(-C)	25	45	162	115	80	20	45	162	115	80	20	45	172	125	80	15	35	162	125	70	
Alpha 15-B-155	12	26	100	72	44	12	26	100	72	44											
Alpha 20-B-225	18	35	122	85	60	12	35	122	85	60	12	35	132	95	60	12	35	132	95	60	
Alpha 30-B-325	18	35	122	85	60	12	35	122	85	60	12	35	132	95	60	12	35	132	95	60	
Alpha 35-B-455	25	45	162	115	80	20	45	162	115	80	20	45	172	125	80	15	35	162	125	70	

All bevel gears are lubricated for life with synthetic oil (lubrication B0). Maximum duty cycle 40 %.
 For a longer duty cycle, please order "lubrication B1" and specify mounting position. Angular play <20 minutes.

Versions:

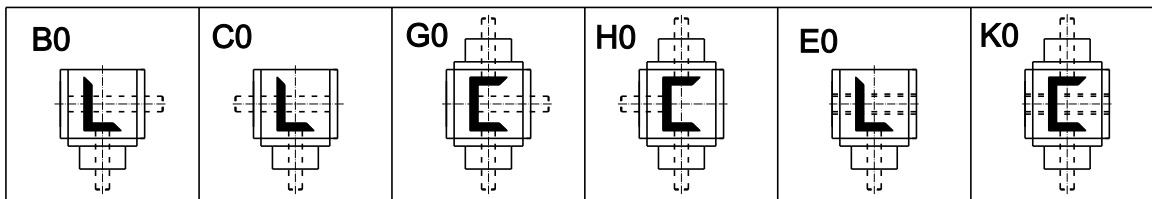

(Pay attention to diameter of sleeve shaft of version E0/K0.)

Allowed output nominal torque (Nm) at input rotation speed 3000 min⁻¹

Atek-Gears

Gear	Ratio i							Ø Sleeve shafts of Version E0 / K0
	1:1	1,5:1	2:1	3:1	4:1	5:1	6:1	
065	10	10	10	10	-	-	-	12
090	27	25	23	23	23	23	23	18
120	66	61	56	58	60	60	54	25

MS-Graessner-Gears

Power Gear	Ratio i					
	1:1	1,5:1	2:1	3:1	4:1	5:1
P54	15	15	12	12	-	-
P75	45	45	42	33	28	25
P90	78	78	68	54	52	40
P110	150	150	150	120	100	85

At allowed values there are only limited** thermal limiting performances considered.
This applies to both producers.
Details see documentation of producers (Atek and MS-Graessner).

** switch-on time ED = 40 %, rotation speed 3000 U/min, ambient temperature 20 °C

Joint shaft mounting (GX)

Toothed belt drive

Threaded spindle drive

Dimension AA = Centre distance between mechanical linear drives

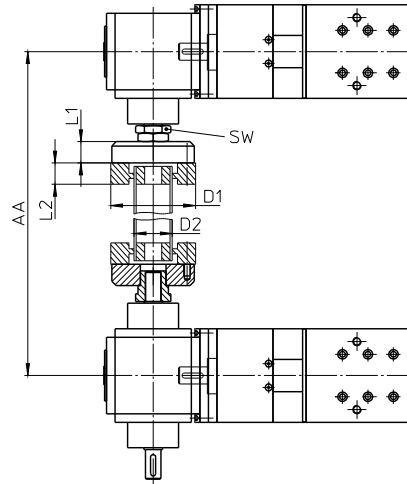
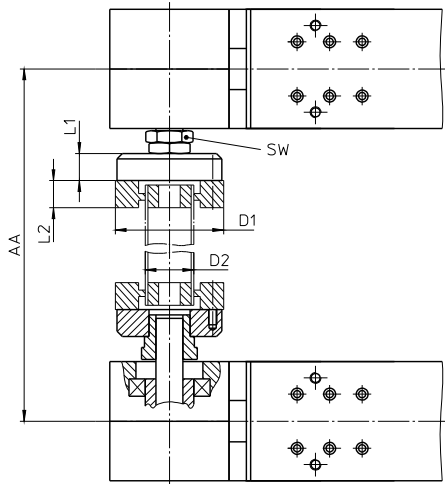

Linear Drive	Size	max. Moment [Nm]	AA min.	SW
Beta 40-ZSS	GX1	8	170	22
Beta 50-C-ZRS	GX1	12	190	22
Beta 60-ZSS	GX2	22	205	27
Beta 60-SSS	GX2		320	22
Beta 60-SGV	GX2		320	22
Beta 70-C-ZRS-ZSS	GX2	31	215	27
Beta 70-C-SRS-SSS	GX2		330	27
Beta 80-ZRS-ZSS	GX2	47	225	27
Beta 80-SRS-SSS	GX2		330	27
Beta 80-C-ZRS-ZSS	GX4	74	270	36
Beta 100-ZRS-ZSS	GX4	89	270	36
Beta 100-D-ZSS	GX4	38	270	36
Beta 100-D-SSS	GX4		290	36
Beta 110-ZRS-ZSS	GX4 / GX8*	191	320	46
Beta 110-SRS-SSS	GX4		350	46
Beta 120-ZRS-ZSS	GX4 / GX8*	153	300	46
Beta 120-C-ZSS	GX4 / GX8*	229	300	46
Beta 120-C-SSS	GX4		350	46
Beta 140-ZRS-ZSS	GX4 / GX8*	140	310	46
Beta 140-SRS-SSS	GX4		350	36
Beta 140-C-ZSS	GX4 / GX8*	140	310	46
Beta 140-C-SSS	GX4		350	36
Beta 165-ZSS	GX16	700	350	55
Beta 165(-C)-SGV / -SSF	GX8		430	46
Beta 165-SSS	GX8		430	46
Beta 180-ZSS	GX8 / GX16*	306	370	55
Beta 180-SSS	GX8		430	46
Beta 180-C-ZSS	GX8 / GX16*	370	370	55
Beta 180-C-SSS	GX8		430	46

Linear Drive	Size	Moment max. [Nm]	AA min.	SW
--------------	------	------------------	---------	----

Gamma 90-ZSS	GX4	77	250	36
Gamma 90-ZSSD	GX2	37	240	36
Gamma 120-ZSS	GX4	90	280	36
Gamma 120-ZSSD	GX4	57	280	36
Gamma 160-ZSS	GX4 / GX8*	153	300	46
Gamma 160-ZSSD	GX4	74	300	46
Gamma 220-ZSS	GX8 / GX16*	306	370	55
Gamma 220-ZSSD	GX4 / GX8*	107	350	46

Sigma 70-ZRS	GX2	22	205	27
Sigma 90-ZRS	GX2	36	240	27
Sigma 90-ZRSD	GX2	18	240	27
Sigma 120-ZRS	GX4	89	280	36
Sigma 120-ZRSD	GX4	57	280	36
Sigma 160-ZRS	GX4 / GX8*	153	300	46
Sigma 160-ZRSD	GX4	77	300	46

Size	D1	D2		L1	L2
		St	VA		
GX1	57	30x2	30x2,0	20	24
GX2	88	40x2,5	40x2,5	20	24
GX4	100	45x2,5	44,5x1,5	25	28
GX8	125	60x2,5	60,3x1,6	30	32
GX16	155	70x1,5	70,0x2,0	50	35

* The larger version is to be selected where necessary.

This table is a selection. More sizes and combinations on request.

Pillow bearing drawing

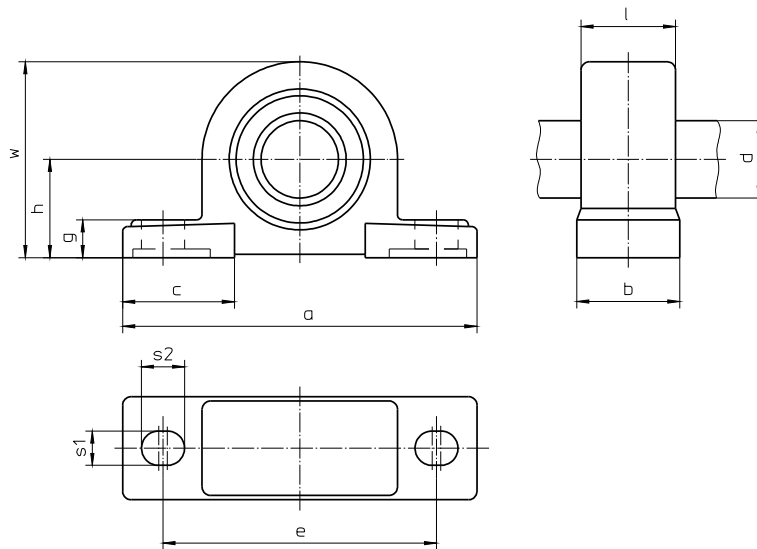

For Joint shaft	a	b	c	d	e	g	h	l	s1	s2	w	Weight in kg			
												Length 500 mm complete		100 mm tube	
												St	VA	St	VA
GX1	167	48	54	30	127	19	47,6	43	17	21	92	1,20	1,21	0,14	0,14
GX2	190	54	60	40	146	20	54	50	17	22	106	2,37	2,42	0,23	0,23
GX4	206	60	65	45	159	22	57,2	55	20	25	114	3,56	3,11	0,26	0,16
GX8	265	70	77	60	203	27	76,2	65	25	29	150	6,08	5,55	0,35	0,23
GX16	292	78	85	70	232	30	88,9	64	25	31	175	11,03	11,37	0,26	0,34

Joint shaft diagram

Depends on length and revolution

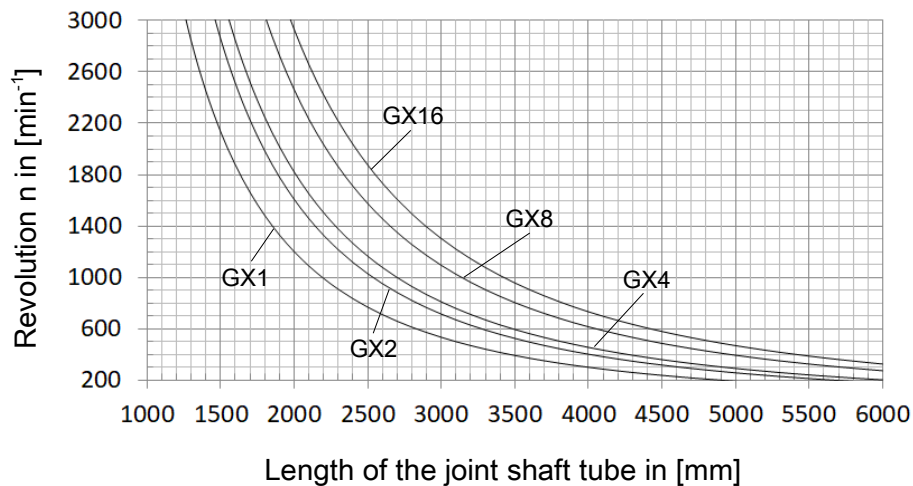

Motor mounting, coupling (MGK)

Standard motor mounting (3-part)

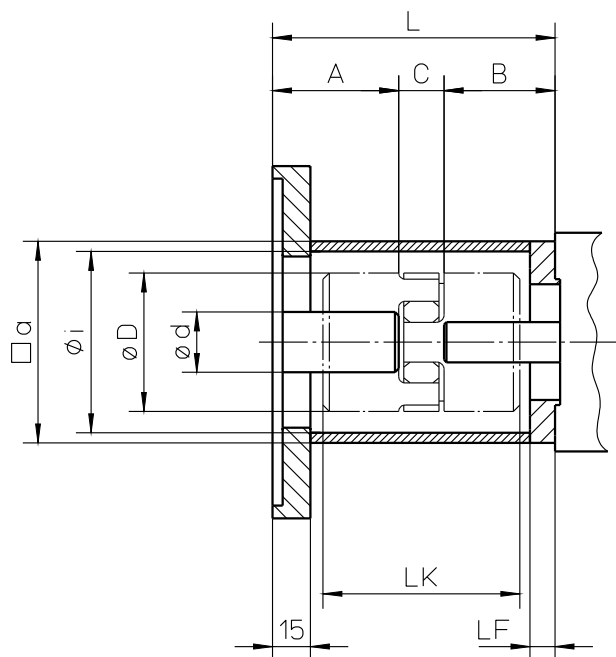

Gr.	a	ϕ_i	LF
55	55	46	8
80	80	69	10

$$L = A + B + C$$

- A = Length of drive shaft of motor/gear
- B = Length of drive journal of mechanical linear drive
- C = See Table for Coupling Sizes

Size of coupling

	9	12	14	19	24	28
C	10	12	13	16	18	20
ϕd_{max}	11	12	16 (14)	20	28	38
ϕD	20	25	30	40	55	65
LK	30	34	35 (50)	66	78	90

Clamping hub and clamping ring (from size 14) possible.
Dimensions in brackets apply for clamping ring.



Chapter X

Custom

Designs

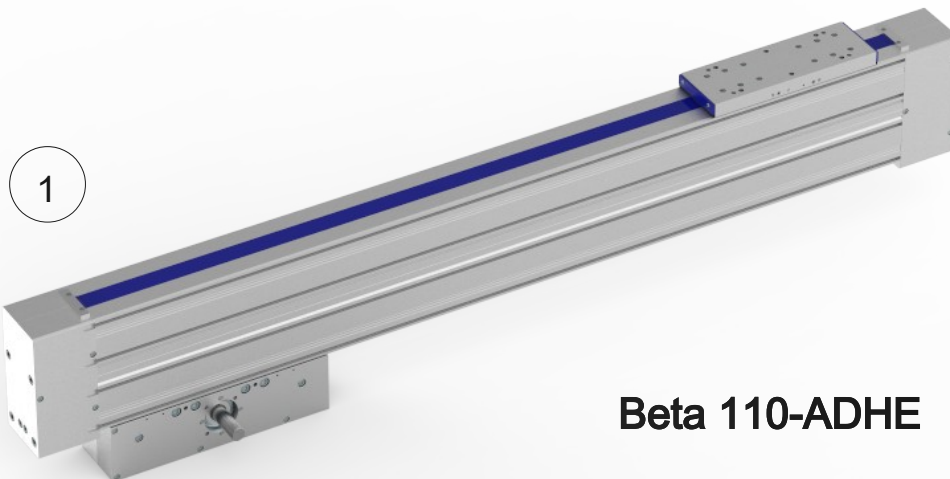

Beta 110-ADHE

The ADHE design (driven carriage, duplex unit) is currently available in sizes 50 and 110 but can in principle be supplied in the HSB-beta® series sizes.

The lower carriage with the gearbox/motor detects that the profile tube and the top carriage are travelling. There is therefore a relative/ double stroke action. An outrigger can be attached to the upper carriage and thereby e.g. a spray lance with a single profile length of the linear unit can be immersed into a tool by the doubled stroke.

The upper linear unit with the single carriage is enclosed by the covering strip.

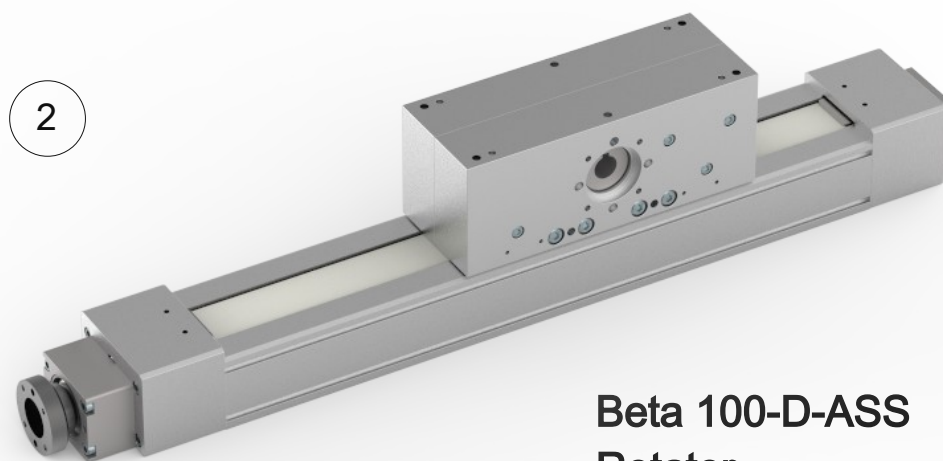

Beta 100-D-ASS Rotator

The HSB-beta®-ARS-ASS versions are often used with a vertical axis.

The carriage and drive are upright and the profile tube runs vertically.

The gripper/attachments often also need to rotate.

This can be implemented very simply with the HSB rotator.

A top and bottom-mounted tube is fed through the rear cavity of the profile.

A servo motor is attached at the top by a timing belt drive (or motor mounting)

while the gripper or attachment can be attached to the adapter plate on the bottom.

HSB-beta®

3

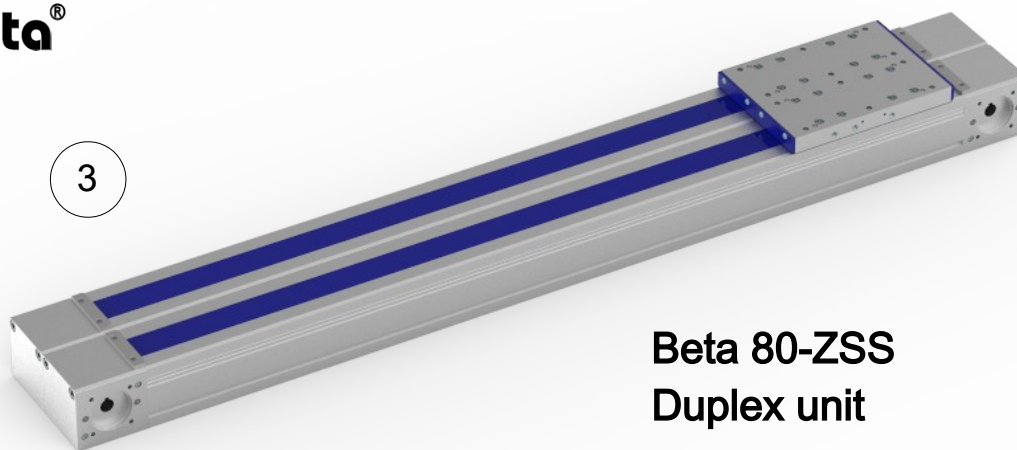
**Beta 80-ZSS
Duplex unit**

4

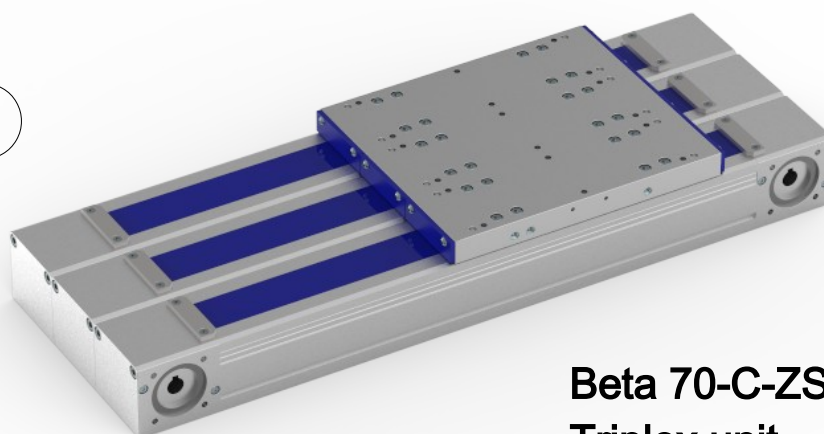
**Beta 70-C-ZSS
Triplex unit**

With a spindle or toothed belt drive, all HSB-beta® series sizes can be converted into duplex/triplex or multiple units.

Profiles are screwed/glued together. The result is a broad, flat linear unit. A shared carriage plate allows large torques to be accommodated in the M_x direction. With a shared drive (toothed belt units) it is possible to generate greater thrust forces.

Counter-acting movements can be implemented with single carriage plates.

If different spindle pitches are used it is possible to realise different speeds from the same engine speed.

HSB-delta[®]

5

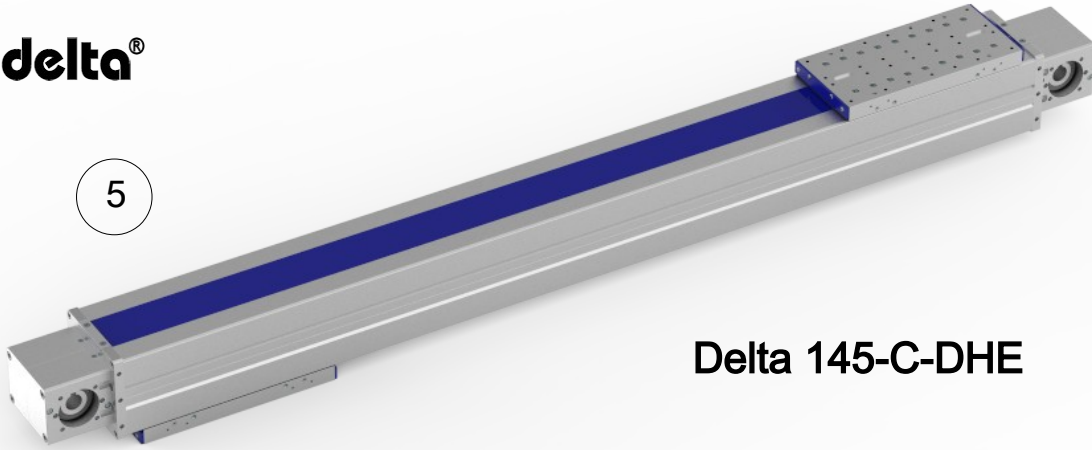

Delta 145-C-DHE

The DHE (double stroke unit) is currently available for the 145 size but other HSB-delta[®] series sizes are possible in principle.

In this case, along with the flat design and large transferable torques, an optimum ratio of stroke to overall length was required due to the duplex design of the HSB-delta[®] series.

HSB-kappa[®]

6

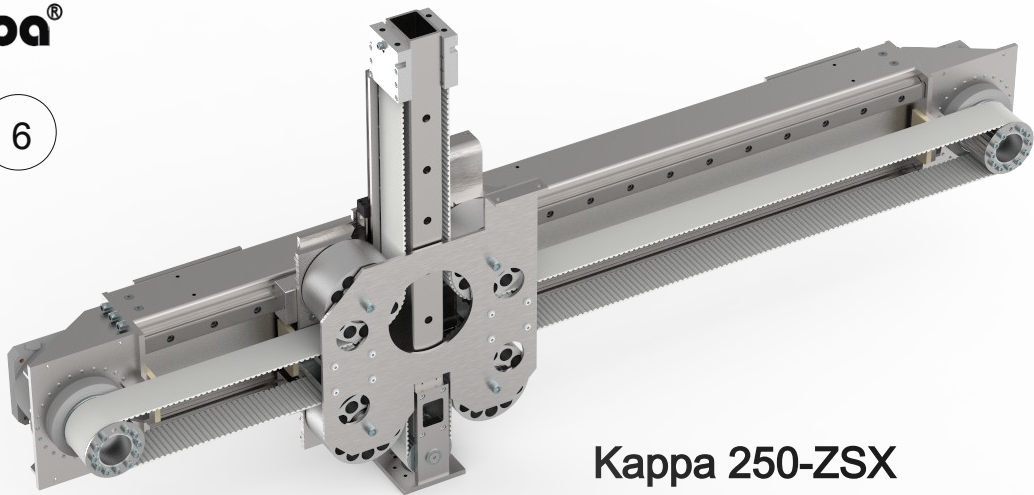

Kappa 250-ZSX

The linear units of the HSB-kappa[®] series are a particular highlight of HSB Automation GmbH.

The function principle is well known and some of our competitors supply and build this concept as a small system. The challenge for HSB Automation GmbH lay not in the system itself but in the parameters to be achieved:

it needed to move a mass of up to 100 kg horizontally by 2000 mm and vertically by 600 mm with 30 strokes/ minute. All components had to be non-rusting since it was for the food industry.

To save mass and weight in the vertical axis conventional linear units were out of the question. The drive which had to be co-transported (gearbox and servomotor with brake) overstressed every system. We therefore opted for the system with two vertical motors and a toothed belt.



Chapter TL

Technology

Linear

Examples of multi-axis systems

Type **HB-beta**[®]

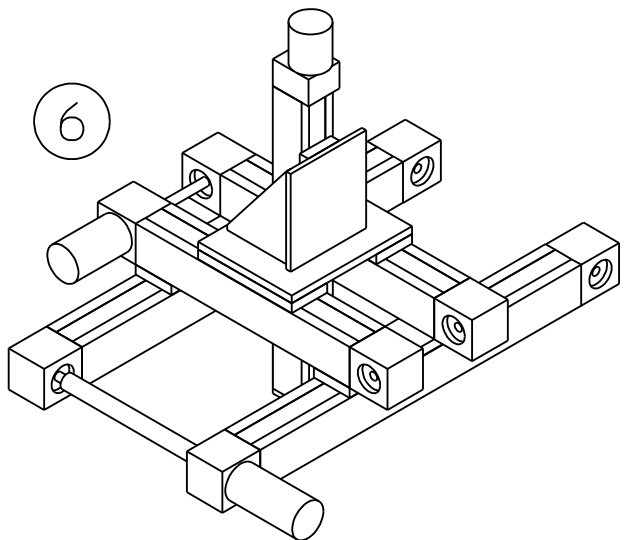
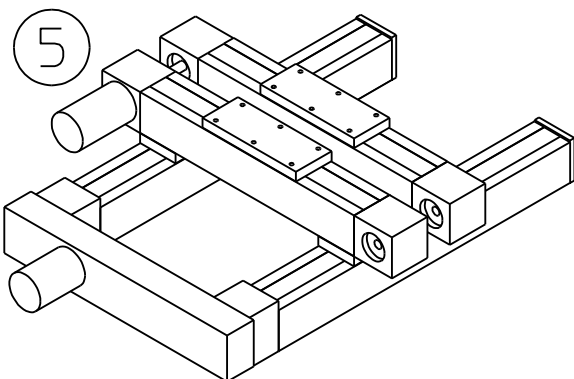
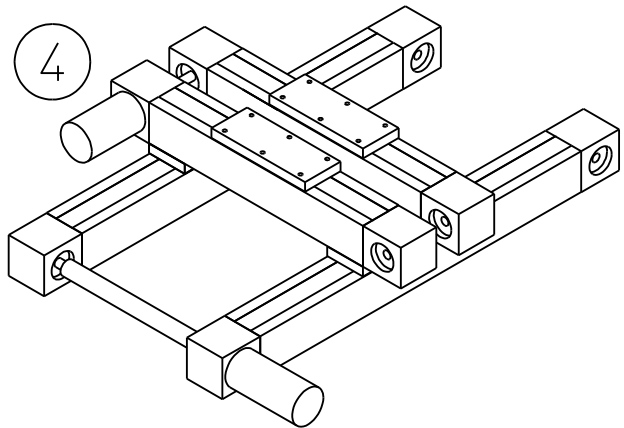
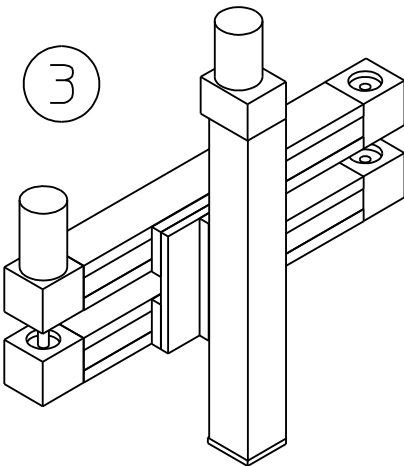
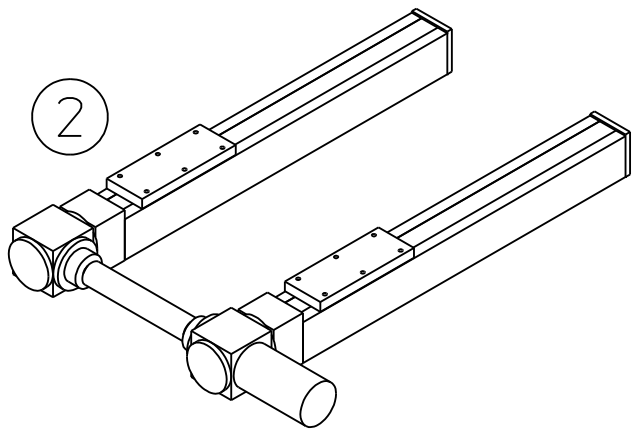
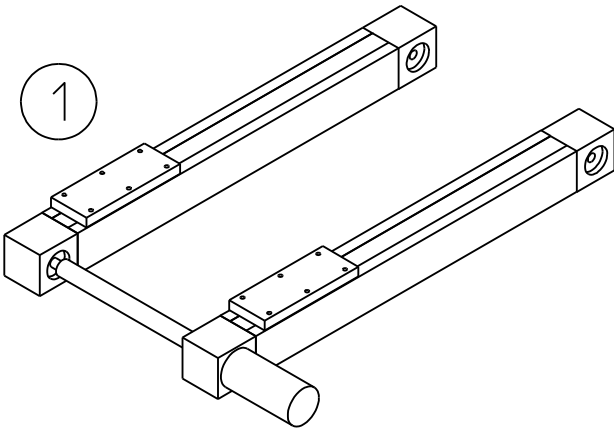

Type **HB-alpha**[®] and **HB-delta**[®]

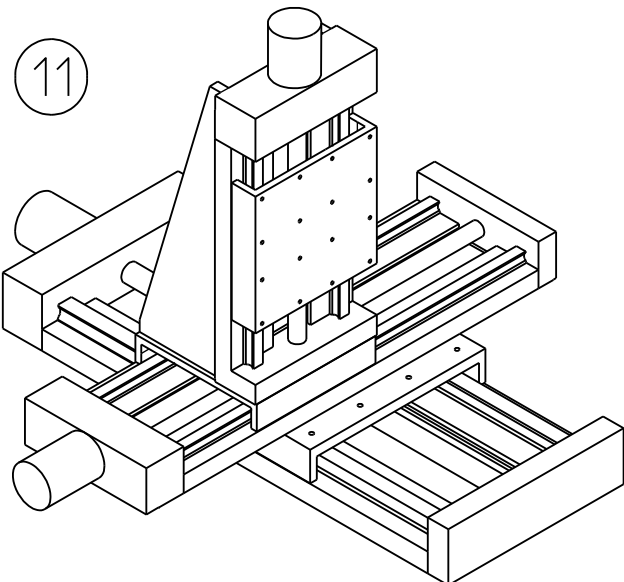
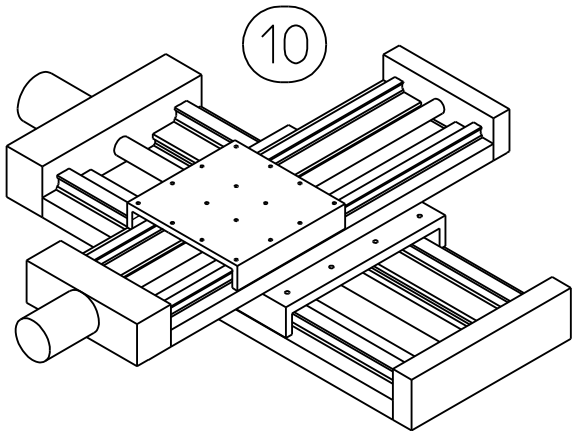
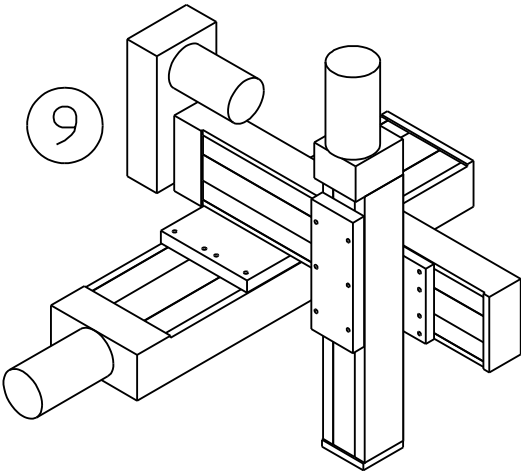
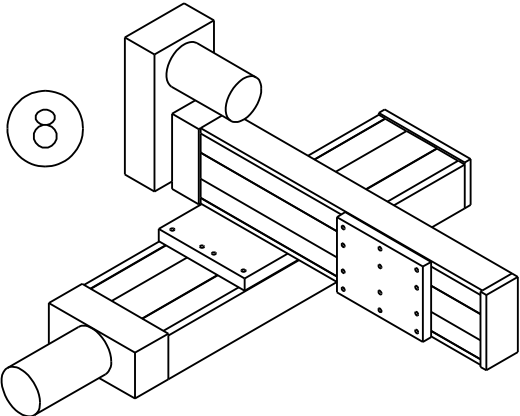
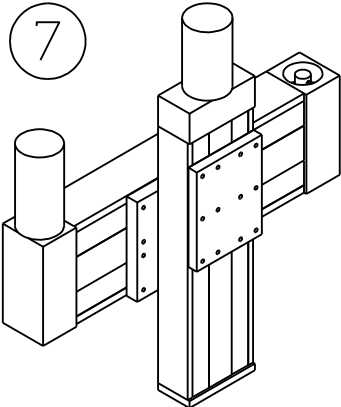

Mechanical Linear Drives



with spindle drive or toothed belt drive
with rail guide or roller guide

Compact Modules



with spindle drive or toothed belt drive
with rail guide

Linear Tables



with spindle drive
with rail guide

Portal Linear Drive



with rack-and-pinion drive or toothed belt drive
with rail guide

Portal Linear Drive



with toothed belt drive
with roller guide

Customised solutions

In accordance with customer requirements (e.g.: ex-protection according to Atex, corrosion-resistant, clean room compatible, toothed belt linear drive right/left, etc.) .

Handling systems

For the most varied of industries

Accessories

Fixing parts, proximity switches, gears, motor mountings, couplings, belt drives with various gear ratios

Selection criteria for the guide system

Roller guide

Smooth travel thanks to optimum rolling characteristics
Low noise thanks to quiet rolling
High moment acceptance thanks to optimum load transmission into profile
Large stroke lengths possible without a problem
Low maintenance due to long-life lubrication of rollers
Low-cost alternative to rail guide

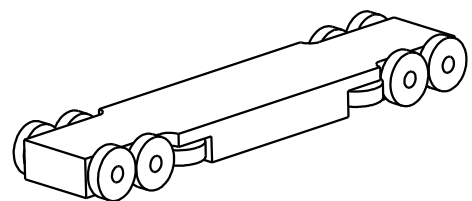

Rail guide

High load capacity of guide
Longer service life
High level of guiding accuracy

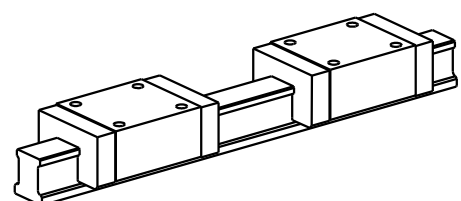

Further information regarding the performance overview

All specifications refer to the standard configuration. The values given for special designs may deviate considerably. The loads specified are the maximum single loads possible for the entire system. If there are different loads (several different forces or moments), the single permissible loads are lower. There may be elastic deformations which will influence the level of accuracy. For mechanical linear drives with roller guides, the static load rating (C_{stat}) applies for static loads.

Repeat accuracy is defined as the ability of the mechanical linear drive to once again return to the same actual position under the same conditions. Conditions such as temperature, load, speed, deceleration and direction of travel may influence the repeat accuracy.

Mechanical Linear Drives with Screw Drive

For calculating service life, the guide and screw drive load ratings are used. Please contact us for further information. The idle torques refer to the respective standard configurations (not double nut or low-backlash single nut) and are measured at a very low speed ($\approx 0 \text{ min}^{-1}$). Production and assembly tolerances vary by $\pm 20 \%$.

The permissible deflection of the linear axis is 0.2 mm/m (1 mm maximum).

For special applications trapezoidal screw drives optional stand for disposal. When used, please ask our technical sales specialists and clarify the exact use.

Mechanical Linear Drives with Toothed Belt Drive

For calculating service life, the guide load ratings are used. Please contact us for further information.

The idle torques refer to the respective standard configurations and are measured at a very low speed ($\approx 0 \text{ min}^{-1}$). Production and assembly tolerances vary by $\pm 20\%$.

The specification for load F_x is the maximum value permitted for low speeds. Please contact us for the maximum value at higher speeds.

The permissible deflection of the linear axis is 0.5 mm/m (2.5 mm maximum).

Running performance and noise

Contingent on the production tolerances in the used components (e.g. screw or toothed belt drive, guide, mounting, etc.), the running behaviour and noise development for linear drives and linear tables can vary enormously even with the same units. Using customised solutions, such as for example longer spindle supports or damping, the running behaviour can be changed for the better.

Straightness and torsion

All aluminium profiles used for the linear devices and the linear tables are extruded profiles.

The straightness and torsion of these profiles may deviate as a result of the manufacturing process.

The permissible deviations in accordance with DIN 17615 are, however, generally far from exceeded.

However, it may be necessary to align the linear drives using suitable levelling elements or

fix them to a mounting surface machined with sufficient accuracy in order to achieve the desired guiding accuracy.

Better tolerances of 0.1 mm / 1000 mm can thus be achieved.

Stroke length

The stroke length specified in the ordering code refers to the maximum permissible stroke.

Acceleration-, braking distances or possible overrun must be taken into consideration here.

We reserve the right to make technical changes to all products!

Drive Dimensions for Mechanical Linear Drives

with screw drive or toothed belt drive

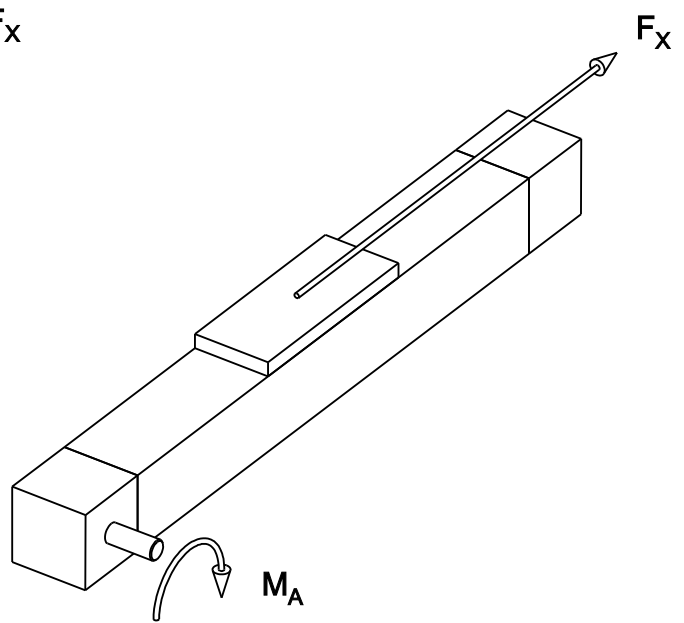
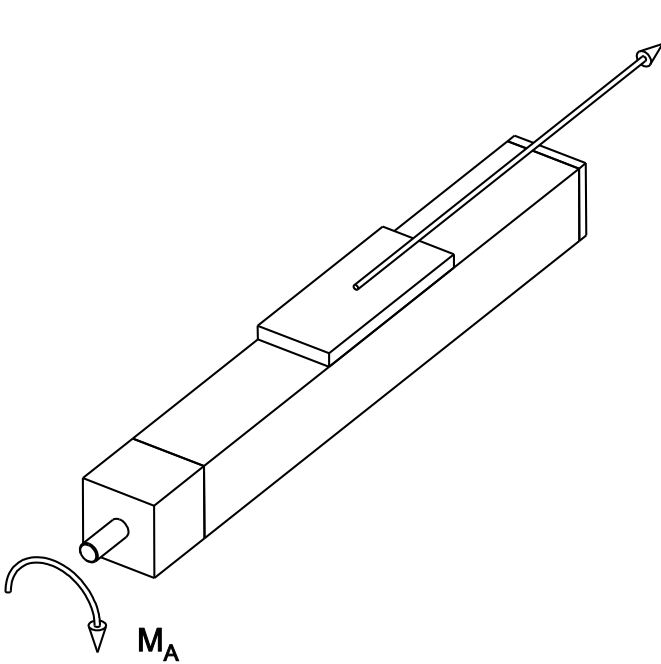

Required drive torque* M_A [Nm]:

$$M_A = M_{load} + M_{idle}$$

Definitions:

- M_A : Required drive torque [Nm]
- M_{load} : Load torque [Nm]
- M_{idle} : See data sheets [Nm]
- F_X : Feed force in horizontal application [N]
Feed force in vertical application [N]

$$M_{load} = \frac{F_x \cdot p}{2 \cdot \pi \cdot 1000}$$

$$F_X = m \cdot g \cdot \mu + m \cdot a$$

$$F_X = m \cdot (g + a)$$

- μ : Friction coefficient for linear guide $\mu = 0.05$
Friction coefficient for roller guide $\mu = 0.02$
Friction coefficient for sliding guide $\mu = 0.1$
- g : Gravitational acceleration [m/s^2] $g = 9.81 m/s^2$
- a : Acceleration [m/s^2]
- m : Transport weight [kg]
- p : Spindle pitch [mm] (screw drive) or stroke per revolution [mm] (toothed belt drive)

* (rough estimate)

Basics for Calculating the Forces and Moments

Forces (**F**) result if

a mass (**m**) being accelerated (**a**).

a mass (**m**) being accelerated due to gravity (**a**).

This means:

$$\mathbf{F_x, F_y = m \cdot a}$$

$$\mathbf{F_z = m \cdot (g + a)}$$

(vertical applications)

A moment is caused by a force (**F**) acting upon a lever arm (**l**).

This means a force is acting off-centre.

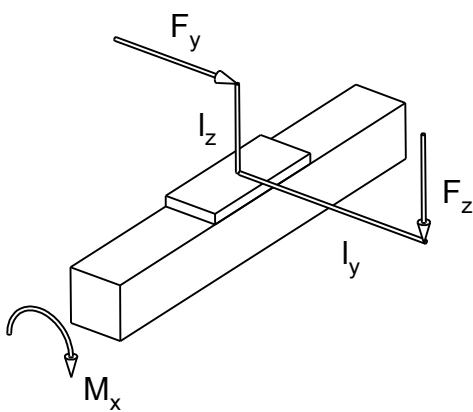

$$\mathbf{M_x = F_y \cdot l_z \text{ or } F_z \cdot l_y}$$

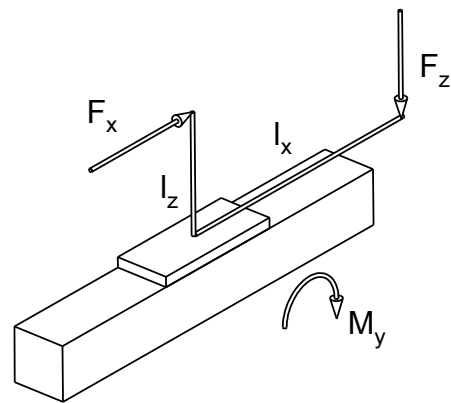

$$\mathbf{M_y = F_x \cdot l_z}$$

$$\mathbf{M_y = F_z \cdot l_x}$$

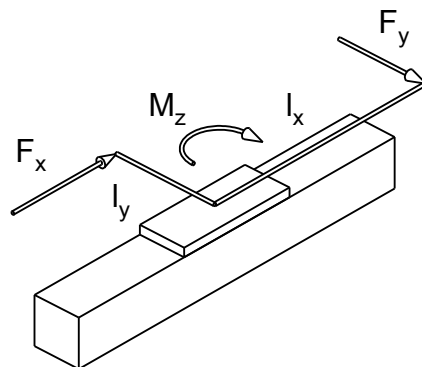

$$\mathbf{M_z = F_x \cdot l_y}$$

$$\mathbf{M_z = F_y \cdot l_x}$$

In most of the applications, there are combinations of these forces.

The resulting end forces must always be smaller than the permitted values.

For calculating service life, the actual forces are used.

(See following pages)

Forces at the roller guide

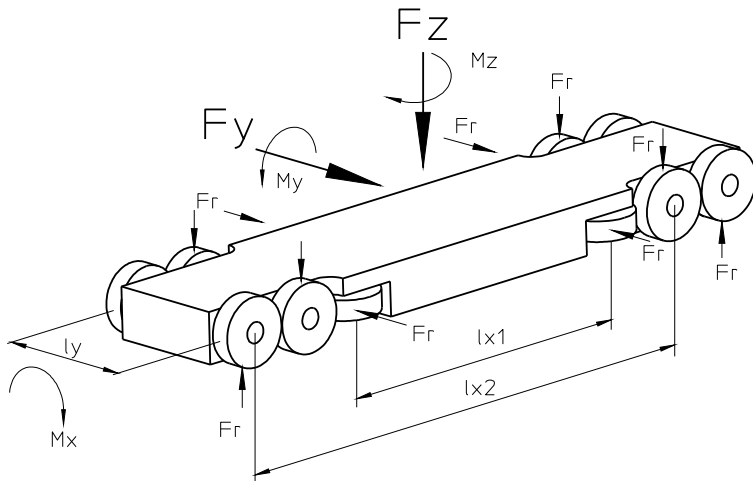

- F_x : Force in feed direction
- F_y : Force in Y direction
- F_z : Force in Z direction
- M_x : Moment for longitudinal axis (X)
- M_y : Moment for lateral axis (Y)
- M_z : Moment for vertical axis (Z)
- F_r : Force on the roller
- l_y : Guiding distance in y direction (see Table on page T11)
- l_{x1} : Guiding distance in x direction (see Table on page T11)
- l_{x2} : Guiding distance in x direction (see Table on page T11)

Direction of force F_y

F_y shared by 2 rollers

$$F_r = F_y \cdot 0.5$$

Direction of force F_z

$+F_z$ and $-F_z$ shared by 4 rollers

$$F_r = F_z \cdot 0.25$$

Moment M_x

M_x shared by 2 rollers

$$F_r = M_x / l_y \cdot 0.5$$

Moment M_y

M_y shared by 2 rollers

$$F_r = M_y / l_{x2} \cdot 0.5$$

Moment M_z

M_z shared by 1 roller

$$F_r = M_z / l_{x1} \cdot 1$$

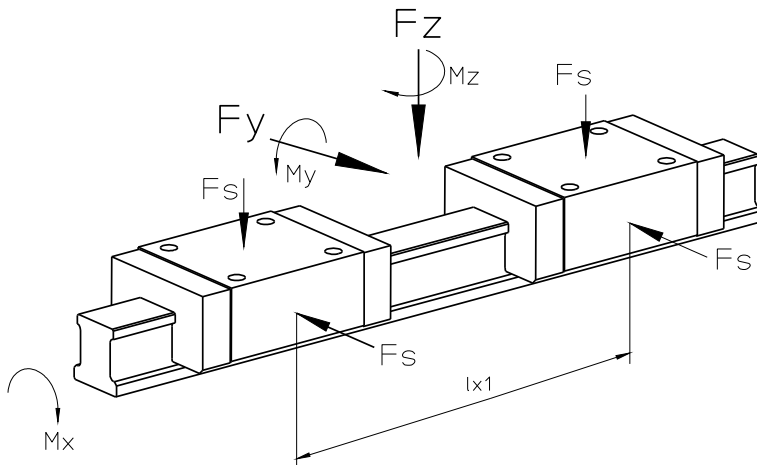

- F_x : Force in feed direction
- F_y : Force in Y direction
- F_z : Force in Z direction
- M_x : Moment for longitudinal axis (X)
- M_y : Moment for lateral axis (Y)
- M_z : Moment for vertical axis (Z)
- M_t : Permissible dynamic moment for the guide carriage
(see Table on page T12)
- C : Dynamic load rating (C_{dyn}) for the guide carriage
(see Table on page T12)
- F_s : Force on a carriage
- l_{x1} : Guiding distance in x direction
(see Table on page T12)

Direction of force F_y

F_y shared by 2 carriages

$$F_s = F_y \cdot 0.5$$

Direction of force F_z

F_z shared by 2 carriages

$$F_s = F_z \cdot 0.5$$

Moment M_x

M_x shared by 2 carriages
With combined external load (F_z and F_y)
in combination with a torsional moment

$$F_s = |F_z| + |F_y| + C \cdot (|M_x| / M_t) \cdot 0.5$$

Moment M_y

M_y shared by 2 carriages
(with opposite direction of force)

$$F_s = M_y / l_{x1} \cdot 1$$

Moment M_z

M_z shared by 2 carriages
(with opposite direction of force)

$$F_s = M_z / l_{x1} \cdot 1$$

Forces at the double rail guide

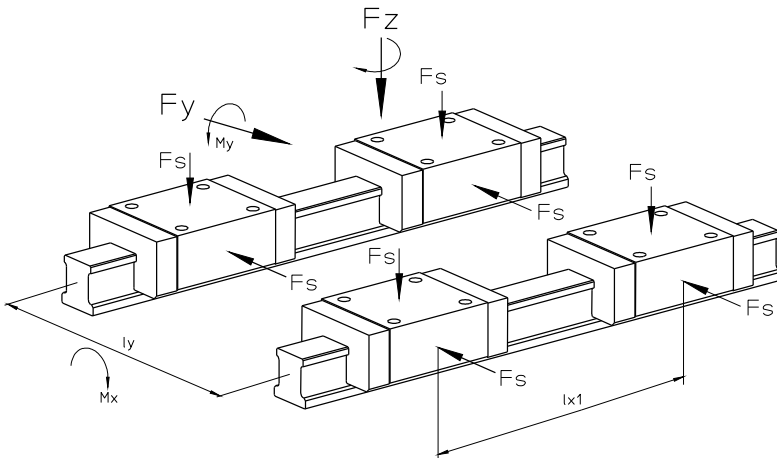

- F_x : Force in feed direction
- F_y : Force in Y direction
- F_z : Force in Z direction
- M_x : Moment for longitudinal axis (X)
- M_y : Moment for lateral axis (Y)
- M_z : Moment for vertical axis (Z)
- F_s : Force on a carriage
- l_y : Guiding distance in y direction (see Table on page T12)
- l_{x1} : Guiding distance in x direction (see Table on page T12)

Direction of force F_y

F_y shared by 4 carriages

$$F_s = F_y \cdot 0.25$$

Direction of force F_z

F_z shared by 4 carriages

$$F_s = F_z \cdot 0.25$$

Moment M_x

M_x shared by 4 carriages
(2 per opposite direction of force)

$$F_s = M_x / l_y \cdot 0.5$$

Moment M_y

M_y shared by 4 carriages
(2 per opposite direction of force)

$$F_s = M_y / l_{x1} \cdot 0.5$$

Moment M_z

M_z shared by 4 carriages
(2 per opposite direction of force)

$$F_s = M_z / l_{x1} \cdot 0.5$$

Service Life of Roller, Rail Guide and Ball Screw

It is primarily the guide values for the mechanical linear drive that are used when calculating nominal service life. The ball screw must also be taken into consideration for the drive with ball screw spindle. With the multitude of parameters crucial for the service life of the entire mechanical linear drive (forces and moments, taking into consideration directions and possible combinations, lead to a moderate load (F_m); ambient conditions, duty cycle...), the following simplified formulae only serve as an initial estimate.

1. Moderate load of the guide or ball screw

$$F_m = (F_1^3 \cdot q_1 / 100 + F_2^3 \cdot q_2 / 100 + F_n^3 \cdot q_n / 100)^{1/3}$$

2. Nominal service life of the roller guide

$$L = (C / F)^3 \cdot 10^5 \cdot R$$

$$F = F_m + F_v$$

3. Nominal service life of the sliding guide

$$L = (C / F)^3 \cdot 10^5$$

$$F = F_m + F_v$$

4. Nominal service life of the ball screw

$$L_{KGT} = (C_{KGT} / F)^3 \cdot 10^6$$

$$F = F_m + F_v \text{ (} F_v \text{ only with double nut (MM); approx. 10 \%)}$$

Definitions

F_m : Moderate load [N] of guide or ball screw

F_1, F_2, F_n : Stepped single load [N]

q_1, q_2, q_n : Stroke rate for F_1, F_2, F_n [%]

L : Nominal service life of guide [m]

C : Dynamic load rating of guide (C_{dyn}) [N] (see Table on pages T11 and T12)

R : Factor for roller guide size

Beta 50 ... Beta 80 + Sigma 70: $R = 0,625$; Beta 80-C + Sigma 90: $R = 0,75$;

Beta 100 + 110 + Sigma 120: $R = 0,87$;

Beta 120 + 140 + Sigma 160: $R = 1,1$;

Delta 90: $R = 0,595$ (Y) und $R = 0,625$ (Z)

F : Equivalent load [N] for guide or ball screw

F_v : Pretensioning [N] (3 % of C_{dyn} , 5 % for roller guide (see Table on pages T11 and T12)

L_{KGT} : Nominal service life of the ball screw [revolutions]

C_{KGT} : Dynamic load rating of the ball screw (C_{dyn}) [N] (see Table on page T13)

Technical Data for Mounted Guides

Static and dynamic load ratings of the roller guides

Unit size	Size (∅) [mm]	Number of supporting rollers for Fz	Number of supporting rollers for Fy	Load rating per roller C _{stat} [N]	Load rating per roller C _{dyn} [N]	Guide distance* in direction x [mm]		Guide distance in direction y [mm]
						lx1	lx2	ly
Beta 50-C	20	4	2	600	1500	86 (136)	86 (136)	30.5
Beta 70-C	20	4	2	600	1500	74 (124)	138.5 (188)	41
Beta 80	20	4	2	600	1500	95 (155)	156.5 (216)	41.5
Beta 80-C	24	4	-	1240	2750	-	148.5	42
		-	2	2300	4200	75	-	-
Delta 90	20	4	-	790	1830	-	100 (180)	54.5
	19	-	2	1370	2700	100 (180)	-	-
Beta 100	28	4	2	1300	3200	136 (256)	223 (343)	47
Beta 110	28	4	2	1300	3200	175 (355)	262 (424)	66
Beta 120	35	4	2	3000	6800	148 (328)	148 (328)	70
Beta 140	35	4	2	3000	6800	202 (352)	202 (389)	98
Beta 140-ARS	35	4	2	3000	6800	272	272	98
Sigma 70	20	4	4	790	1830	67 (117)	71 (121)	57
Sigma 90	24	4	4	1240	2750	76 (126)	99 (149)	77
Sigma 120	28	4	4	1300	3200	130 (260)	160 (290)	99
Sigma 160	35	4	4	3000	6800	145 (295)	177 (327)	135

The pretensioning per roller is approx. 5 %.

() = Data for long entire carriage and Sigma ARH

Technical Data for Mounted Guides

Dynamic load ratings of the rail guides (THK and Rex = Rexroth)

Unit size	Size	Number of rails	Number of guiding carriages per carriage	Load rating per carriage C_{dyn} [N] THK / Rex	Pretensioning F_v [N] THK / Rex	M_t [Nm] THK / Rex	Guide distance* in	
							direction x [mm] lx1	direction y [mm] ly
Beta 40	12	1	2	3175 / 2310	-	25 / 14	83 (163)	-
Beta 60	15	1	2	11271 / 9860	564 / 620	60 / 74	106 (156)	-
Beta 70-C	15	1	2	11271 / 9860	564 / 620	60 / 74	124 (174)	-
Beta 80	20	1	2	17700 / 23400	885 / 1500	210 / 240	128 (188)	-
Beta 80-C	25	1	2	25160 / 28600	1258 / 1820	340 / 320	122 (182)	-
Beta 100	20	1	2	17700 / 23400	885 / 1500	210 / 240	152 (272)	-
Beta 100-D-ZSS	15	2	4	11271 / 9860	564 / 620	-	150 (210)	56
Beta 100-D-ASS	15	2	4	11271 / 9860	564 / 620	-	192	56
Beta 100-D-SSS	15	2	4	11271 / 9860	564 / 620	-	150 (210)	56
Beta 110	25	1	2	25160 / 28600	1258 / 1820	340 / 320	203 (383)	-
Beta 120	25	1	2	25160 / 28600	1258 / 1820	340 / 320	144 (324)	-
Beta 120-C	30	1	2	35558 / 36500	1778 / 2540	580 / 540	184 (364)	-
Beta 140	15	2	4	11271 / 9860	564 / 620	-	180 (330)	72
Beta 140-ASS	15	2	4	11271 / 9860	564 / 620	-	242 (322)	72
Beta 140-C-ZSS	20	2	4	17700 / 23400	885 / 1500	-	220 (400)	76
Beta 140-C-ASS	20	2	4	17700 / 23400	885 / 1500	-	220 (300)	76
Beta 140-C-SSS	20	2	4	17700 / 23400	885 / 1500	-	210 (360)	76
Beta 165-ZSS	35	1	2	49448 / 51800	2472 / 3350	985 / 890	198 (398)	-
Beta 165-SSS	35	1	2	49448 / 51800	2472 / 3350	985 / 890	219 (329)	-
Beta 165-C-SSF	30L	2	4	43018 / 46000	2151 / 3200	-	280	128
Beta 180-ZSS	20	2	4	17700 / 23400	885 / 1500	-	172 (392)	84
Beta 180-ASS	20	2	4	17700 / 23400	885 / 1500	-	306	84
Beta 180-SSS	20	2	4	17700 / 23400	885 / 1500	-	247 (467)	84
Beta 180-C-ZSS	25	2	4	25160 / 28600	1258 / 1820	-	272 (492)	84
Beta 180-C-ASS	25	2	4	25160 / 28600	1258 / 1820	-	307	84
Beta 180-C-SSS	25	2	4	25160 / 28600	1258 / 1820	-	233 (453)	84
Delta 110-C	15	2	4	11271 / 9860	564 / 620	-	75 (195)	66
Delta 145-C	20	2	4	17700 / 23400	885 / 1500	-	87 (207)	87
Delta 200	25	2	4	25160 / 28600	1258 / 1820	-	144 (294)	126
Delta 240(-C)	25	2	4	25160 / 28600	1258 / 1820	-	200 (320)	150
Alpha 15B	15	2	4	11271 / 9860	564 / 620	-	94 (164)	105
Alpha 20B	20	2	4	17700 / 23400	885 / 1500	-	143 (243)	160
Alpha 30B	30	2	4	35558 / 36500	1778 / 2540	-	205 (335)	240
Alpha 35B	35L	2	4	57861 / 66700	2893 / 4450	-	286 (436)	340
Gamma 90-ZSS	15	2	4	11271 / 9860	564 / 620	-	135 (285)	73
Gamma 90-ZSSD	15	2	4	11271 / 9860	564 / 620	-	75	73
Gamma 90-ASH	15	2	4	11271 / 9860	564 / 620	-	265	73
Gamma 90-AZS.	15	2	4	11271 / 9860	564 / 620	-	255	90
Gamma 120-ZSS	20	2	4	17700 / 23400	885 / 1500	-	170 (320)	90
Gamma 120-ZSSD	20	2	4	17700 / 23400	885 / 1500	-	76	90
Gamma 120-ASH	20	2	4	17700 / 23400	885 / 1500	-	320	90
Gamma 120-AZS.	20	2	4	17700 / 23400	885 / 1500	-	320	115
Gamma 160-ZSS	25	2	4	25160 / 28600	1258 / 1820	-	208 (408)	120
Gamma 160-ZSSD	25	2	4	25160 / 28600	1258 / 1820	-	208 (408)	120
Gamma 160-ASH	25	2	4	25160 / 28600	1258 / 1820	-	408	120
Gamma 160-AZS.	25	2	4	25160 / 28600	1258 / 1820	-	408	151
Gamma 220-ZSS	25L	2	4	29208 / 37300	1460 / 2430	-	210 (390)	180
Gamma 220-ZSSD	25L	2	4	29208 / 37300	1460 / 2430	-	210 (390)	180
Gamma 220-ASS	25L	2	4	29208 / 37300	1460 / 2430	-	390	180
Gamma 220-AZS.	25L	2	4	29208 / 37300	1460 / 2430	-	440	196
Gamma 280-ZSS	35	2	4	49448 / 51800	2472 / 3350	-	275 (475)	236
Gamma 280-ZSSD	35	2	4	49448 / 51800	2472 / 3350	-	275 (475)	236
Gamma 280-AZSS	35	2	4	49448 / 51800	2472 / 3350	-	480	253

* Data in () refer to long standard carriage

Technical Data for Mounted Ball Screws

Dynamic load ratings for ball screw

Unit size		Nominal \varnothing in [mm]	Pitch in [mm]	C_{dyn} [N]
Beta 40 Beta 50-C	Delta 90	12	5 10	3800 4300
Beta 70-C	Delta 110-C	16	5 10 20 40	12800 14300 8100 8500
Beta 60 Beta 80 Beta 100-D	Delta 145-C	20	5 10 20 50	14600 13500 11500 12300
Beta 80-SGV Beta 110 Beta 140(-C)		25	5 10 25 50	16100 15100 15800 14500
Beta 110-C-SGV Beta 120-C Beta 180(-C)	Delta 200 Delta 240(-C)	32	5 10 20 40 60	26200 33100 30200 15200 14100
Beta 165 Beta 110-C-SGV		40	5 10 20 40	23800 38000 33300 35000
Beta 165-C-SGV Beta 165-C-SSF		50	10 20	68700 60000
Alpha 15B		20	5 20	14600 13500 11500 12300
Alpha 20B		25	5 10 25	16100 15100 15800 14500
Alpha 30B		32	5 10 20 40	26200 33100 30200 15200
Alpha 35B		40	5 10 20 40	29100 50000 37900 37000

(Dynamic load rating for ball screw nut in accordance with DIN 69051, 1989)

Maintenance instructions for THK and Rexroth rail guide

For all guide carriage sizes, the relubrication interval is approx. 5000 km for the carriage with ball chain or approx. 2000 km for the carriage without (Rexroth without ball chain / standard). It is dependent on several factors, i.e. operating temperature, load, degree of pollution, etc. Grease quantity depends on the guide carriage (see Table).

Size	15	20	25	30	35
Guide	THK				
Quantity [cm ³]	0.4	0.6	1.2	1.5	1.7
Guide	Rexroth				
Quantity [cm ³]	0.8	1.4	2.8	4.4	4.4

Klüberplex BE 31-102 is used for the initial lubrication. (When using other roller bearing greases, please take note of the manufacturer's instructions!) Roller bearing greases with a solid lubricant percentage (e.g. graphite or MoS₂) is not to be used.

Please refer here to our assembly and maintenance instructions.

Maintenance instructions for roller guide

The track of the roller guide should be lubricated every 5000 km. The standard oil used by our company is Febis K68 or INTERFLON fin super.

Please refer here to our assembly and maintenance instructions.

Maintenance instructions for ball screw

For ball screws, relubrication intervals depend on the pitch and the spindle diameter:

KGT 12xx to 32xx after approx. 2.5×10^7 overrolling movements

KGT 40xx and 50xx after approx. 1.5×10^7 overrolling movements

KGT-Type	[Size]	1205	1210	1605	1610	1620	1640	2005	2010	2020	2050	2505	2510	2525	2550
Quantity	[cm ³]	0,55	0,55	1,70	1,80	1,70	1,80	2,00	2,10	2,30	4,50	2,60	3,40	3,10	4,80

KGT-Type	[Size]	3205	3210	3220	3232	3240	3260	4005	4010	4020	4040	5010	5020
Quantity	[cm ³]	4,20	5,60	4,60	5,30	3,00	4,60	5,30	15,40	10,20	9,50	25,90	26,50

Klüberplex BE 31-102 is used for the initial lubrication. (When using other roller bearing greases, please take note of the manufacturer's instructions!) Roller bearing greases with a solid lubricant percentage (e.g. graphite or MoS₂) is not to be used.

In general, ball screw spindles should be protected against contamination. A cover band (standard) or a bellows can be used here.

Please refer here to our assembly and maintenance instructions.

Note: PRESSOL 12226 (125 cm³) one-hand grease gun with spout and corresponding coupler can be ordered from us.

Other maintenance instructions

The relubrication interval and the relubrication amount are generally influenced by many factors (e.g. speed, temperature, ambient conditions, etc.). For this reason, only reference values have been given here. Relubrication should take place at least every two years.

The relubrication should take place "in motion".

Note: The customer is required to carry out a basic lubrication after commissioning!

All mounted ball bearings are sealed and maintenance-free.

The toothed belt is also maintenance-free and must only be replaced if an excess load leads to the breakage or elongation of the elastic area.

Excessive dust and contamination on the toothed belt and at the cover band should be regularly removed.