



Präzisionswellen
Precision shafts



Linear-Komponenten
Linear components



Laufrollenführung
Track roller guidance system



Alle Angaben dieser Druckschrift wurden mit großer Sorgfalt erstellt und überprüft. Für eventuelle Fehler oder Unvollständigkeiten können wir jedoch keine Haftung übernehmen. Technische Änderungen behalten wir uns vor. Der Nachdruck, auch auszugsweise, nur mit unserer Genehmigung.

© EXXELLIN GmbH - 2015, September

Für Lieferungen und sonstige Leistungen im kaufmännischen Geschäftsverkehr gelten die allgemeinen Bedingungen für Lieferungen und Leistungen, die in der jeweils gültigen Preisliste und auf den Auftragsbestätigungen aufgeführt sind.

This publication has been produced with a great deal of care and attention and all data have been checked for their accuracy. However, no liability can be assumed for any incorrect or incomplete data. Due to constant development of the product range, we reserve the right to make modifications. Reproduction in whole or in part without our authorization is prohibited.

© EXXELLIN GmbH - 2015, September

The sales and delivery conditions in the relevant valid price list and on order confirmations apply for deliveries and for other commercial transactions.

Der EXXELLIN-Ansatz: Spezialisierung und Kompetenz

The EXXELLIN approach: Specialisation and competence

EXXELLIN ist ein junges Unternehmen: Es wurde 2008 gegründet und hat sich von Anfang an auf die Fertigung hochgenauer Präzisionswellen spezialisiert - ein Bereich, in dem unser Team über langjährige und umfassende Erfahrungen verfügt.

Eine hochmoderne, von EXXELLIN konzipierte und errichtete Fertigungsstätte in der Nähe von Magdeburg (Sachsen-Anhalt) bietet ein ideales Umfeld für Qualität und Effizienz.

Nachhaltigkeit als Schlüssel zum Erfolg

Als gesellschaftergeführtes Unternehmen setzt EXXELLIN auf eine nachhaltig gesunde Entwicklung.

Werte wie Einsatzbereitschaft und Loyalität spielen für unseren Erfolg eine ebenso große Rolle wie technische Kompetenz und betriebswirtschaftliches Know-how. Unseren langfristigen Unternehmenserfolg sichern wir durch nachhaltiges Handeln und einem verantwortungsvollen Umgang mit Kunden, Lieferanten, Mitarbeitern und der Umwelt.

Klar definierte Produktpalette

Unser Produktions-Portfolio umfasst Präzisionswellen, Tragschienen, Wellenböcke, Linear-Kugellager (Kugelhülsen, Kugelbüchsen), Lineargehäuse-Einheiten, Profillaufrollen. Darüber hinaus bearbeiten wir Produkte vollständig gemäß den Anforderungen unserer Kunden.

Für uns spielt es keine Rolle, ob es um kurzfristige Lieferungen ins In- und Ausland geht oder um Just-in-time-Service: Wir bieten Ihnen die passende Lösung.

Damit der Kunde wieder kommt, nicht das Produkt

Für EXXELLIN ist Qualität nicht nur ein Wort. EXXELLIN praktiziert Qualität quer durch alle Bereiche und Tätigkeiten wie Organisation, Vertrieb, Produktentwicklung, Produktion, Materialwirtschaft oder Planung. Dabei achten wir nicht nur auf die Verantwortlichkeiten, Methoden, Verfahren, Prozesse und Ressourcen: Wir kümmern uns ebenso um deren konsequente Umsetzung, ständige Verbesserung, Erfüllung und Bewertung.

Unser Ziel: Fehlerquote Null

Als Konsequenz und sichtbares Zeichen unserer Verpflichtung zur Qualität haben wir ein Qualitätsmanagementsystem aufgebaut. Um dessen Prozesse überprüfen und bestätigen zu lassen, haben wir uns im Winter 2010 nach DIN ISO 9001:2008 zertifizieren lassen.

EXXELLIN is a young company: It was established in 2008 and right from the outset specialised in the production of precision shafts - a field where our team has extensive and long-standing experience.

A state-of-the-art production plant designed and built by EXXELLIN close to Magdeburg (Saxony-Anhalt) offers an ideal environment for quality and efficiency.

Sustainability as the key to success

As a partner-managed enterprise, EXXELLIN relies on sustainably healthy development.

For our success, such values as commitment and loyalty play just as important a role as technical competence and business know-how. We secure our long-term corporate success by sustainable action and responsible dealings with our customers, suppliers, employees and the environment.

Clearly defined range of products

Our production portfolio covers precision shafts, shaft support rail units, shaft support blocks, linear ball bearings, Linear housing units, track rollers. Over and above this, we process products to fall fully in line with our customers' requirements. It doesn't matter to us whether the deliveries are on short notice for home or abroad, or whether our just-in-time service is being called on: We will offer you the appropriate solution.

Ensuring the customer returns and not the product

For EXXELLIN, quality is not merely a word. EXXELLIN practises quality across all fields and activities such as organisation, sales, product development, production, materials management and control or planning. Here, we not only pay careful attention to the responsibilities, methods, procedures, processes and resources involved: We also take equal care of their consistent realisation, constant upgrading, compliance and rating.

Our objective: A zero error rate

As an upshot and visible token of our commitment to quality, we have established a quality management system. In order to have these processes checked and confirmed, we have ourselves certified in accordance with DIN ISO 9001:2008 in winter 2010.

Präzisionswellen

Precision shafts



Produktübersicht

Product overview

Typ Type	Bezeichnung Series	Abmessungsbereich Size range	Herstelllänge Production length	Normaltoleranz Standard tolerance	Sondertoleranz Special tolerance	Werkstoff Material	Beschichtung Coating	Tabelle Table
Präzisionsstahlwellen Precision shafts	W	3 - 100 mm	6000 mm	h6	h7	z.B. / e.g. Cf53 1.1213 59 HRC min.	-	S. 17
Präzisionsstahlwellen, verchromt Precision shafts, chrome-plated	WV	6 - 100 mm	6000 mm	h7	h6	z.B. / e.g. Cf53 1.1213 59 HRC min.	Chromschicht Chrome layer 800 HV min. ca. 10 µm	S. 21
Präzisionsstahlwellen, korrosionsbeständig X90 Precision shafts, stainless steel X90	WKA	4 - 100 mm	6000 mm	h6	h7	X90CrMoV18 1.4112 54 HRC min.	-	S. 22
Präzisionsstahlwellen, korrosionsbeständig X46 Precision shafts, stainless steel X46	WKB	3 - 100 mm	6000 mm	h6	h7	X46 Cr13 1.4034 52 HRC min.	-	S. 23
Präzisionsstahlwellen, zöllig Precision shafts, inch size	WZ	¼" - 3"	6000 mm	L	S	z.B. / e.g. Cf53 1.1213 59 HRC min.	-	S. 24
Hohlwellen Hollow shafts	WH	12 - 80 mm	6000 mm	h6	h7	z.B. / e.g. C60 1.0601 59 HRC min.	-	S. 25

Allgemein

Präzisionswellen sind Maschinenelemente, die sich neben der hohen Werkstoffqualität, Oberflächenhärte und Oberflächengüte durch eine große Maß- und Formgenauigkeit auszeichnen.

Anwendung

Hierdurch sind die Präzisionswellen beispielsweise für folgende Anwendungen bestens geeignet:

- Führungswelle in Verbindung mit Linear-Kugellagern, Kurven-, Stütz- und Profillaufrollen;
- Führungsstange für Gleitlagerungen;
- Streck- und Richtwalzen;
- Wellen und Achsen im allg. Maschinenbau.

Korrosionsarme Stähle

Speziell zum Einsatz in Medizintechnik, Nahrungsmittelindustrie sowie Productronic werden Präzisionswellen aus X46 oder X90 angeboten.

Hartverchromung

Sind hohe Verschleißfestigkeit und erhöhte Korrosionsbeständigkeit gegenüber Vergütungsstahl gefordert, sind hierzu hartverchromte Präzisionswellen bestens geeignet.

Sonderbeschichtungen

Weitere Beschichtungen wie ZnFe oder Spezial-Verchromungen auf Anfrage.

General Information

Precision shafts are machine elements that in addition to high material quality, surface hardness, and surface quality are characterized by high precision in terms of dimension and shape.

Application

This makes precision shafts extremely well-suited for applications like the following:

- Guide shaft in combination with linear bearings, cam and ball bearing rollers;
- Guide shaft for mounting by plain bearing;
- Stretch and straightening rolls;
- Shafts and axles in fixture construction and automation design.

Low-corrosion steels

Precision shafts from X46 or X90 are available for use in medical technology, the food industry, and productronics.

Hard chrome plating

If high wear resistance and improved corrosion resistance compared to quenched and tempered steel are required, hard chrome plated precision shafts are perfect for the job.

Special coatings

Further coatings such as ZnFe or special chrome coatings upon request.

Materialgüte

Die zur Herstellung der Präzisionswellen verwendeten Vergütungsstähle sind generell normalisiert.

- Verfeinerung des Gefüges;
- Durch die weitgehend gleichmäßige Verteilung des Ferrit-Perlit Gefüges gute Zerspanungseigenschaften;
- Somit geringer Werkzeugverschleiß.

Randhärte tiefe

Damit Wälzlagerungen wie Linearkugellager auf den Präzisionsstahlwellen sicher funktionieren, ist bei der Auslegung der Randhärte tiefe (Rht) der Hertz'sche Spannungszustand zu beachten:

- Die Randhärte tiefe ist die Tiefe, in der noch 80% der Oberflächenhärte als Grenzhärte vorliegt;
- Unter der Oberfläche einer Laufbahn mit einer Kraft Q_c belasteten Kugel entsteht eine dreiaxiale Spannung;
- Die maximale Spannung tritt in einem bestimmten Abstand zur Laufbahnoberfläche auf;
- Der Härteverlauf (1) muss bis zu Kernbereich des Materials so verlaufen, dass die aus der Härte umwertbare Festigkeit an allen Stellen über dem Vergleichsspannungsverlauf (2) aus der dreiaxialen Spannung liegt.

Material quality

The quenched and tempered steels used for the manufacture of precision shafts are generally normalized.

- Refining of the grain structure;
- The largely even distribution of the ferrite-pearlite structure provides good chipping properties;
- This results a low tool wear.

Surface hardening depth

For rolling bearings like linear ball bearings to work reliably with precision steel shafts, the Hertzian contact stress must be considered during design of the surface hardening depth (SHD):

- The surface hardening depth is the depth of the hardened zone in which 80% of the surface hardness is present as a limit hardness;
- Under the surface of a track with a ball carrying force Q_c , there is a three-axis stress;
- The maximum stress occurs at a certain distance from the surface of the track;
- The hardness characteristic (1) must run into the core area of the material in such a way that the rigidity derived from the hardness is higher than the comparison stress curve (2) of the three-axis stress at all points.



Bild / Fig. 1: Härteverlauf / Distribution of hardness

Wellen- / Shaft- \varnothing dw [mm]	Randhärte tiefe (Rht) / Surface hardening depth (SHD) [mm]
$dw \leq 10$	0,4 min.
$10 < dw \leq 18$	0,6 min.
$18 < dw \leq 30$	0,9 min.
$30 < dw \leq 50$	1,5 min.
$50 < dw \leq 80$	2,2 min.
$80 < dw \leq 100$	3,2 min.

Tabelle / Table 1: Randhärte tiefe nach ISO 13012 / Surface hardening depth according to ISO 13012

Dauerfestigkeit

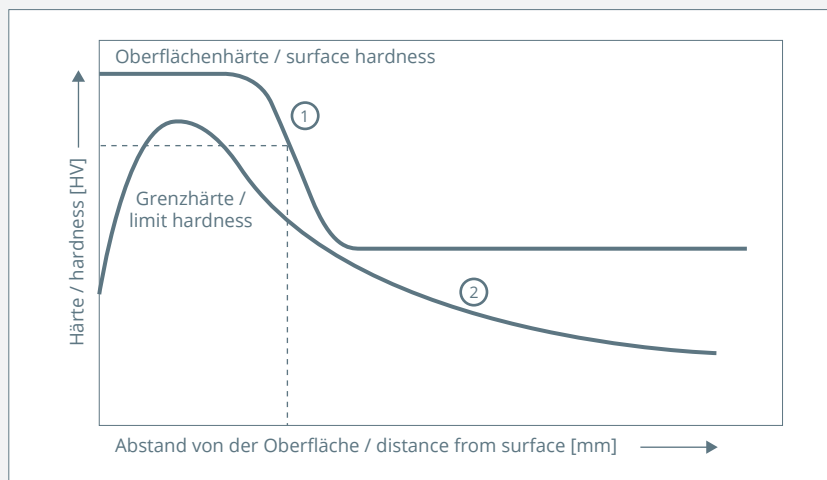
Durch das Randschichthärten werden Druckeigenspannungen im Bereich der Härtezone aufgebaut, diese führen zu einer Verbesserung der Dauerfestigkeit insbesondere bei Wechselbiegung.

Durability

Surface hardening is used to build up internal compressive stress in the hardening zone, leading to improvement in fatigue resistance, particularly in case of alternating bending.



Bild / Fig. 2: Dauerfestigkeit / Fatigue resistance

Geringere Laufbahnhärte

Werden korrosionsbeständige Präzisionswellen aus:

- X46 Cr13 / 1.4034
- X90 CrMoV18 / 1.4112

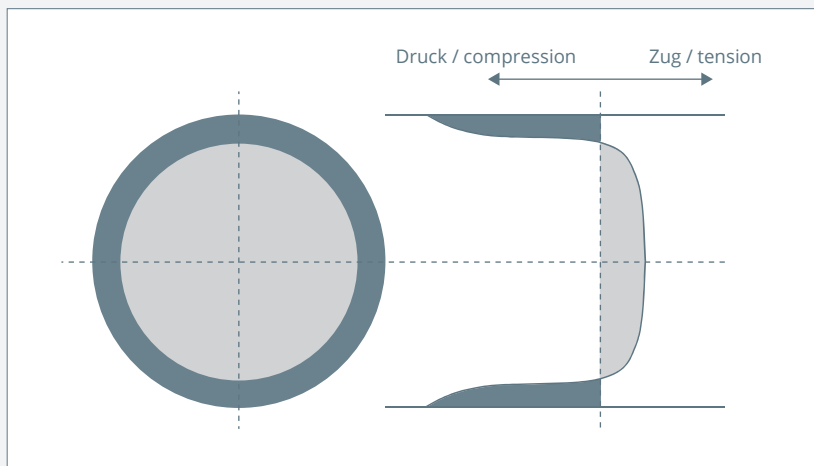
für eine Wälzlagerung verwendet, verringern sich die dynamische und statische Tragzahl C und C_0 durch die geringere Laufbahnhärte der Wellen.

Die wirksame dynamische und statische Tragzahl C_H und C_{0H} wird mittels der Härtefaktoren f_H und f_{0H} aus Bild 3 berechnet:

$$C_H = f_H \cdot C$$

$$C_{0H} = f_{0H} \cdot C_0$$

CoH, CH [N]

wirksame statische und dynamische Tragzahl bei Minderhärte der Welle

fH0, fH [-]

statischer und dynamischer Härtefaktor (Bild 3)

C0, C [N]

statische und dynamische Tragzahl des Linearlagers

Lower track hardness

If corrosion-resistant precision shafts from:

- X46 Cr13 / 1.4034
- X90 CrMoV18 / 1.4112

are used for a rolling bearing, the dynamic and static load ratings C and C_0 are reduced due to the lower track hardness of the shafts.

CoH, CH [N]

effective static and dynamic load with lower hardness

fH0, fH [-]

static and dynamic hardness factor (Fig. 3)

C0, C [N]

static and dynamic load of linear bearing



Bild / Fig. 3: Statische und dynamische Härtefaktoren bei Minderhärte der Laufbahn / Static and dynamic hardness factors for lower hardness of shaft

Hinweis

- Durch die Randschichthärtung ist die Korrosionsbeständigkeit der Präzisionswellen aus X46 und X90 an den Stirnseiten nur eingeschränkt;
- Um Ablagerungen von unedleren Metallen an der Oberfläche von korrosionsbeständigen Präzisionswellen zu vermeiden, sollte die Bearbeitung mit Vollhartmetall- oder Keramikwerkzeugen durchgeführt werden. Dadurch lässt sich Oberflächenkorrosion (Flugrost) vermeiden.

Note

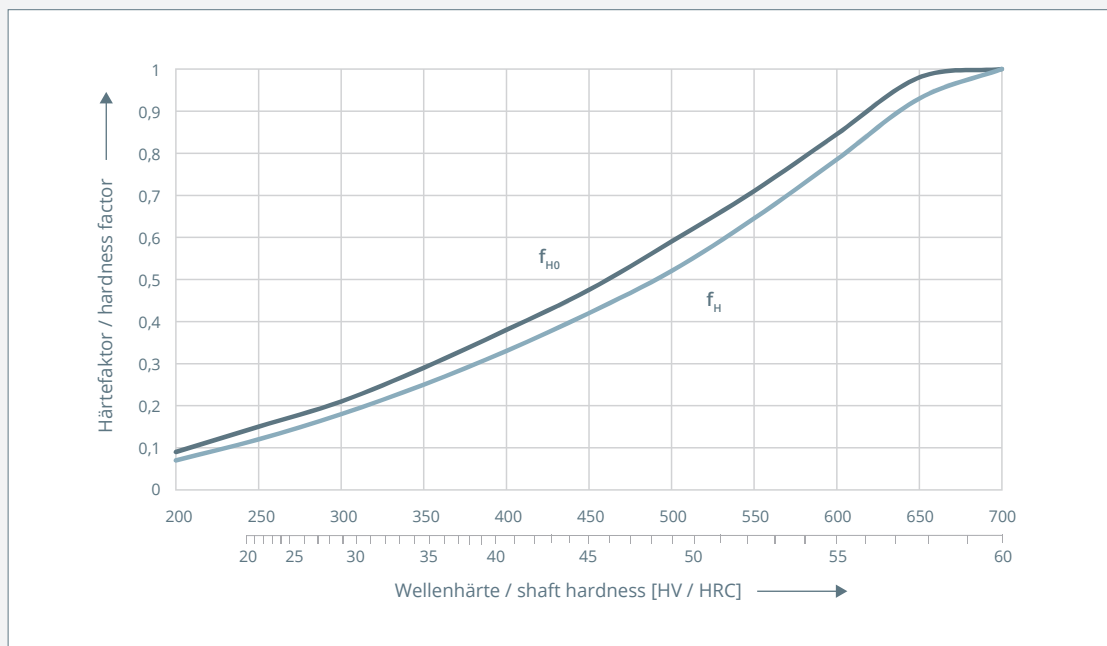
- Surface hardening only limits the corrosion resistance of X46 and X90 precision shafts on the faces;
- To avoid deposits of more base metals on the surface of corrosion-resistance precision shafts, machining should be carried out using solid carbide or ceramic tools. This allows surface corrosion (rust bloom) to be avoided.

Trennschnitt

Die Präzisionswelle wird auf Länge getrennt und die Stirnseiten durch einen manuellen Kantenbruch entgratet. Eine weitere Bearbeitung erfolgt nicht. Der Trennschnitt ist Standard (Bild 4).

Fase

Werden die Präzisionswellen als Führungswellen für Linearkugellager verwendet, müssen die Stirnseiten angefasst werden, damit beim Aufschieben der Linearkugellager keine Beschädigungen am Kugelsatz oder den Dichtringen auftritt. Hierzu gibt es:

- Die Normalfase (Bild 5), Nachsatz NF;
- Oder die Sonderfase (Bild 6), Nachsatz SF, hierbei sind Fasenwinkel α und Fasenlänge b frei wählbar.

Separating cut

The precision shaft is cut to length and the faces are deburred using a manual chamfer. No other processing is done. The separating cut is standard (Figure 4).

Chamfer

If the precision shaft are to be used as guide shafts for linear ball bearings, the faces must be chamfered to avoid damage to the ball bearings or sealing rings during insertion of the linear ball bearings. There are two options:

- A normal chamfer (Figure 5), index NF;
- Or the special chamfer (Figure 6), index SF, where the chamfer angle α and chamfer length b can be selected arbitrarily.



Bild / Fig. 4: Trennschnitt / Cut



Bild / Fig. 5: Normalfase / Standard chamfer

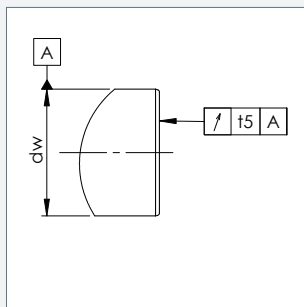

Bild / Fig. 6: Sonderfase / Special chamfer

Wellen- / Shaft- Ø dw	Planlauf t5 / Axial runout t5	Fasenlänge / Chamfer length tf
[mm]	[mm]	[mm]
$dw \leq 10$	0,2	$1,0^{+1}$
$10 < dw \leq 30$	0,3	$1,5^{+1}$
$30 < dw \leq 100$	0,5	$2,5^{+1}$

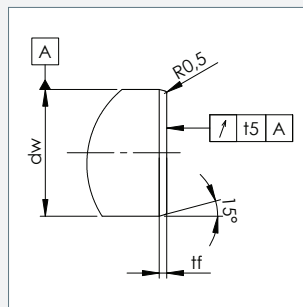
Tabelle / Table 2: Fase / Chamfer

Wellenbearbeitung Machining of shafts

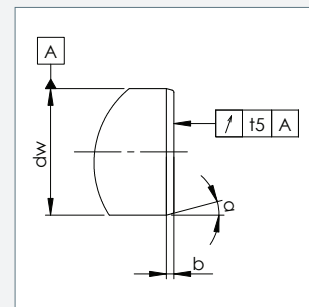
Geradheit

Die Standard-Geradheit ist vom Wellendurchmesser abhängig. Die Werte sind in Tabelle 3 angegeben.



Bild / Fig. 7: Geradheit / Straightness

Straightness

The standard straightness depends on shaft diameter. The values are shown in table 3.

Durchmesser / Diameter d_w [mm]	Geradheit / Straightness t_3 [mm]
$d_w \leq 4$	0,3
$5 < d_w \leq 8$	0,2
$10 \leq d_w$	0,1

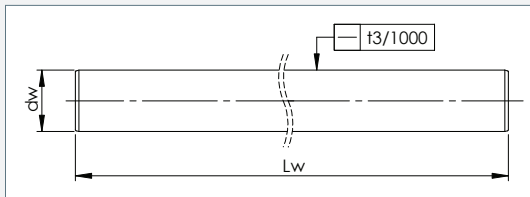
Tabelle / Table 3: Geradheit / Straightness

Geradheitsmessung nach ISO 13012

Wird eine Welle, wie dargestellt, gestützt und um 360° gedreht:

- Keine Ablesung über dem gesamten Messbereich darf die Geradheitstoleranz übersteigen;
- Die Messwerte betragen das Zweifache der tatsächlichen Geradheitstoleranz der Welle.

Straightness measurement per ISO 13012

If a shaft is supported as shown and turned by 360°:

- No measurement may exceed the straightness tolerance over the entire measurement range;
- The measured values are twice the actual straightness tolerance of the shaft.



Bild / Fig. 8: Messung Geradheit / Measuring of straightness

Längentoleranz

Die Längentoleranzen sind abhängig von der Länge der getrennten Wellen.

Length tolerance

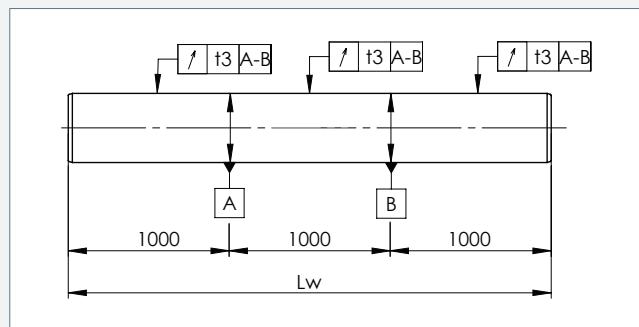
The length tolerances depend on the length of the shaft cut.

Wellenlänge / Shaft length L_w [mm]	Längentoleranz / Length tolerance [mm]
$L_w \leq 400$	$\pm 0,5$
$400 < L_w \leq 1000$	$\pm 0,8$
$1000 < L_w \leq 2000$	$\pm 1,2$
$2000 < L_w \leq 4000$	$\pm 2,0$
$4000 < L_w \leq 6000$	$\pm 3,0$

Tabelle / Table 4: Längentoleranz nach ISO 13012 / Length tolerance according to ISO 13012

Zusammengesetzte Wellen

Sind die benötigten Präzisionswellen länger als die übliche Herstelllänge, werden diese zusammengesetzt geliefert.

- Die Einzelstücke entweder verzapft (I) oder verschraubt (II);
- Die Stoßstellen sind markiert, beim Zusammenschrauben ist auf deren Übereinstimmung zu achten;
- Verzapfte Wellen müssen an der Stoßstelle grundsätzlich unterstützt werden.

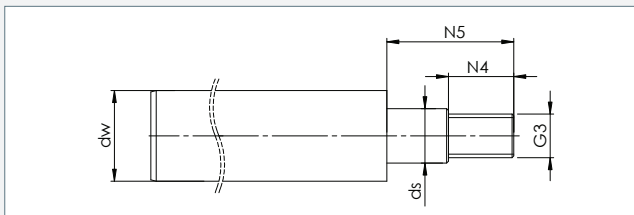
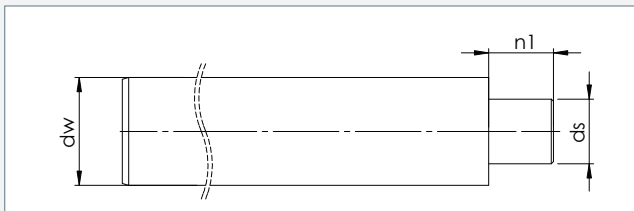

Compound shafts

If precision shaft longer than the usual manufacturing length, they are provided in a compound form.

- The individual pieces are joined either as a mortise (I) or screw connection (II);
- The joints are marked, and they must be matched up when the system is screwed together;
- Mortised shafts must always be supported at the joints.



Bild / Fig. 9: Zusammengesetzte Wellen / Compound shafts

Typ / Type	dw	ds [g6]	di [H7]	G3	N4	N5	N6	N7	n1	n2
	[mm]	[mm]	[mm]	[mm]	[mm]	[mm]	[mm]	[mm]	[mm]	[mm]
W12	12	7	7	M6	9	16	8	19	8	9
W16	16	10	10	M8	12	20	10	25	10	12
W20	20	12	12	M10	12	20	10	25	10	12
W25	25	15	15	M12	22	35	20	41	15	18
W30	30	15	15	M12	22	39	20	45	19	22
W40	40	20	20	M16	26	48	25	55	23	26
W50	50	25	25	M20	33	60	30	67	30	33
W60	60	25	25	M20	33	60	30	67	30	33
W80	80	40	40	M20	35	71	40	81	31	36

Tabelle / Table 5: Zusammengesetzte Wellen / Compound shafts

Wellenbearbeitung Machining of shafts

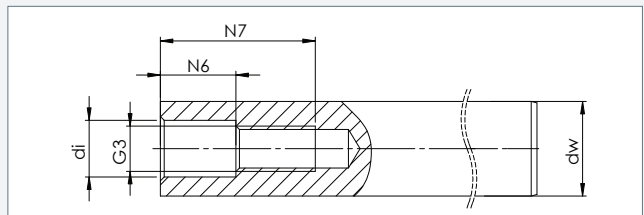
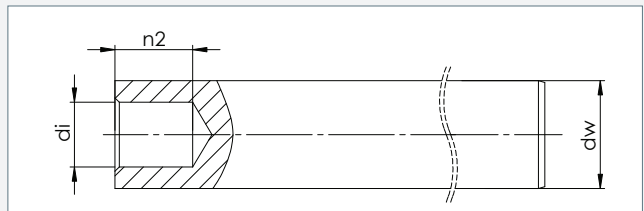
Radial- / Axialgewinde

Sollen die Präzisionswellen mit einer Wellenunterstützung kombiniert werden, sind Radialbohrungen notwendig.

- Radialbohrungen werden in die bereits gehärteten und geschliffenen Präzisionswellen eingebracht;
- Gewindegröße und Gewindetiefe sind vom Wellendurchmesser abhängig (Tabelle 6).



Bild / Fig. 10: Radialgewinde / Radial thread

Radial / axial threads

If precision shaft are to be combined with shaft support, radial holes are needed.

- Radial holes are drilled in the precision shaft after hardening and grinding;
- Thread size and depth depend on the diameter of the shaft (Table 6).

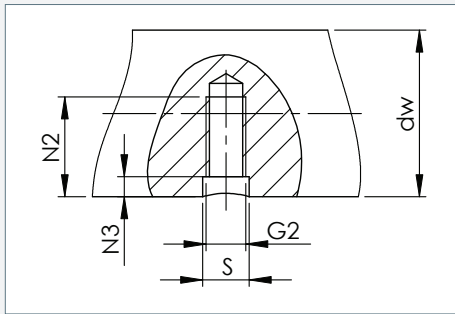

Bild / Fig. 11: Axialgewinde / Axial thread

Typ / Type	G_2 [mm]	S [mm]	N_3 [mm]	N_2 (min) [mm]
W12 - W15	M4	5	2	7 (min)
W16 - W20	M5	6	2,5	9 (min)
W20 - W25	M6	7	3	11 (min)
W25 - W30	M8	9	3	15 (min)
W30 - W40	M10	11	4	19 (min)
W40 - W50	M12	13	4	21 (min)
W50 - W60	M14	15	4	25 (min)

Tabelle / Table 6: Radialgewinde / Radial thread

Typ / Type	G_1 [mm]	$2 \times G_1$ [mm]
W8 - W10	M3	6
W10 - W12	M4	8
W12 - W14	M5	10
W14 - W20	M6	12
W15 - W25	M8	16
W18 - W40	M10	20
W24 - W50	M12	24
W30 - W80	M16	32
W50 - W80	M20	40
W60 - W80	M24	48

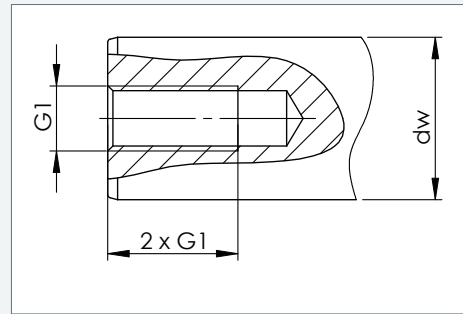
Tabelle / Table 7: Axialgewinde / Axial thread

Sonderbearbeitung

Bei Bedarf werden Sonderbearbeitungen nach Kundenwunsch durchgeführt. Hierbei ist eine große Vielfalt von Formen und Kombinationen möglich. Nachfolgend sind einige Bearbeitungsmöglichkeiten aufgeführt:

- Zapfen mit Paßfedernut
- Abflachung
- Axial- / Radialgewinde
- Außengewinde
- Einstich
- Quernut

Special processing

If necessary, special processing can be carried out according to the needs of the customer. A great variety of shapes and combinations is possible. A few processing options are listed below:

- Journal with feather key groove
- Flattening or flutes
- Axial / radial threads
- External threads
- Clearance groove
- Crosswise groove



Bild / Fig. 12: Sonderbearbeitung / Special processing

Spezielle Anwendungen Special applications

Maßstabile Präzisionswellen

Werden gehärtete Präzisionswellen in Anwendungen mit einer Umgebungstemperatur > 120 °C verwendet, besteht die Gefahr von unerwünschten Maßänderungen infolge innerer Gefügeumwandlungen.

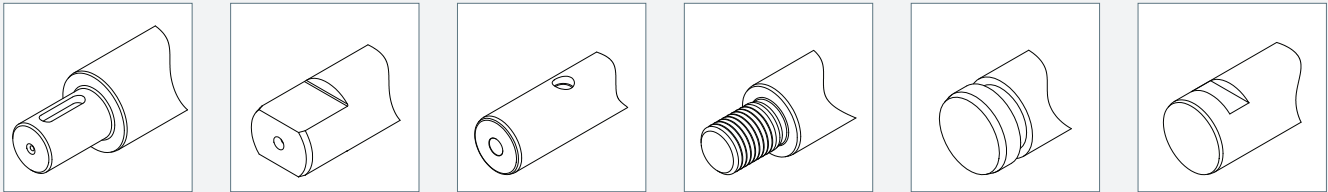
Deshalb werden auf Anfrage Wellen mit Maßstabilisierung ähnlich DIN 623-1 angeboten.

Bezeichnung / Designation	Stabilität bis / Stability up to	Härte / Hardness
	[°C]	[HRC]
S0	150	58 (min.)
S1	200	56 (min.)
S2	250	54 (min.)

Tabelle / Table 8: Maßstabile Präzisionswellen / Dimension-stable precision shaft

Die Minderhärte der Welle ist bei Lebensdauerberechnungen entsprechend zu berücksichtigen.

Erhöhte Randhärte tiefe

Sollen beispielsweise Nuten oder Profile nachträglich in die Welle geschliffen werden, sind erhöhte Randhärte tiefen sinnvoll. Diese werden auf Anfrage angeboten.

Dimension-stable precision shaft

If hardened precision shaft are used in applications with an ambient temperature > 120 °C, there is a risk of undesired changes in dimension due to internal structure changes.

For this reason, shafts are available upon request with dimensional stabilization similar to DIN 623-1.

The minimum hardness of the shafts must be taken appropriately into consideration during lifetime calculations.

Increased surface hardening depth

For example, if grooves or profiles should be ground into the shaft after processing, increased surface hardening depths are practical. These are offered upon request.

Verchromte Präzisionsstahlwellen

Chrome plated precision shafts

Prozess

Die Chromschicht wird galvanisch auf Präzisionswellen bei einer Temperatur zwischen 50 °C - 60 °C aufgetragen, weswegen keinerlei Gefügeveränderungen entstehen.

Der Verchromungsprozess läuft in einem kontinuierlichen Prozess einer Durchlauf-Verchromungsanlage ab. Dies hat im Vergleich zur konventionellen Gestell-Verchromung folgende Vorteile:

- Durch kontinuierlichen Prozess gleichmäßige Chrombeschichtung ohne stromdichteabhängige Schichtdickenunterschiede („Knocheneffekt“);
- Chrombeschichtung über die ganze Länge der Welle ohne unbeschichtete Bereiche oder Kontaktstellen bis 6 Meter;
- Hohe Prozessfähigkeit;
- Umweltschonend, da die Durchlauf-Verchromungsanlage ein geschlossenes System darstellt.



Bild / Fig. 13: Konventioneller Prozess / Conventional process

Eigenschaften der Beschichtung

- Hohe Verschleißfestigkeit
- Bei Wälzlageranwendungen Verhinderung von Riffelbildung bei Stillstandsschwingungen
- Niedriger Reibungskoeffizient
- Zusätzlicher Verschleißschutz für Wälzlager bei Mischreibung
- Anti-Haftwirkung durch geringe Adhäsionswirkung
- Gute Korrosionsbeständigkeit am Außendurchmesser

Anwendung

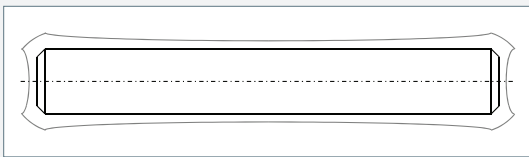
Da die Chromschicht kein Cr(VI) enthält, eignet sich diese Beschichtung für den Einsatz in der Lebensmittelindustrie, Medizintechnik, usw.

Produktkurzzeichen / Product ID	WV
Schichtdicke / Layer thickness	ca. 10 µm
Schichthärte / Layer hardness	800HV - 1100HV
Anzahl der Schichten / Number of layer	1
Korrosionsschutz / Corrosion protection	Gut, kann durch Finishen gesteigert werden / Good, can be improved by belt polishing
Verschleißschutz / Wear protection	Bei Mischreibung / Mixed friction
Max. einteilige Länge / Max. single length	6000 mm / L > 6000 mm auf Anfrage / L > 6000 mm upon request
Cr(VI) frei / free	Ja / yes

Tabelle / Table 9: Zusammenfassung / Summary

Prozess

The chrome layer is galvanically applied to precision shafts at a temperature between 50 °C and 60 °C, do that no structural changes occur.

The chrome plating process takes place as a continuous process in a chrome plating system. This has the following advantages over conventional frame chrome plating:

- The continuous process provides an even coating of chrome, without flow density dependent differences in coating thickness (“bone effect”);
- Chrome coating over the entire length of the shaft without uncoated areas or contact points for up to 6 meters;
- High processing capability;
- Environmentally friendly, since the continuous chrome plating system is a closed system.



Bild / Fig. 14: Kontinuierlicher Prozess / Continuous process

Properties of the coating

- High wear resistance
- In roller bearing applications, prevention of formation of false brinelling under vibration while stationary
- Low coefficient of friction
- Additional wear protection for roller bearings subject to mixed friction
- Anti-stick effect due to low adhesion effect
- Good corrosion resistance to outer diameter

Application

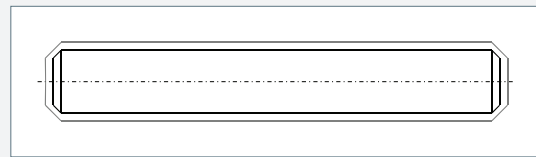
Since chrome layer does not contain Cr(VI), this coating is suitable for use in the food industry, medical technology, etc.

Präzisionswellen W

Precision shafts W

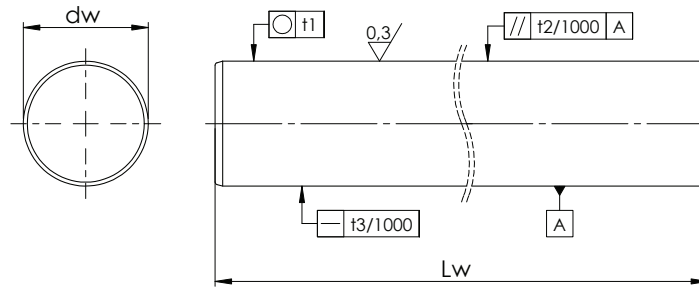

Abmessungen Dimensions (mm)		Gewicht Weight		Toleranz Tolerance	Rundheit Circularity	Parallelität ¹⁾ Parallelism	Geradheit ²⁾ Straightness	Rht (min) ³⁾ SHD (min)
Typ Type	dw	Lw	Gew kg/m	ISO h6 µm	t1 µm	t2 µm	t3 mm	ISO 13012 mm
W3	3	2000	0,055	0 / -6	3	4	0,3	0,4 ⁴⁾
W4	4	2000	0,098	0 / -8	4	5	0,3	0,4 ⁴⁾
W5	5	3000	0,154	0 / -8	4	5	0,2	0,4 ⁴⁾
W6	6	6000	0,222	0 / -8	4	5	0,2	0,4
W8	8	6000	0,394	0 / -9	4	6	0,2	0,4
W10	10	6000	0,616	0 / -9	4	6	0,1	0,4
W12	12	6000	0,888	0 / -11	5	8	0,1	0,6
W14	14	6000	1,208	0 / -11	5	8	0,1	0,6
W15	15	6000	1,387	0 / -11	5	8	0,1	0,6
W16	16	6000	1,578	0 / -11	5	8	0,1	0,6
W18	18	6000	1,997	0 / -11	5	8	0,1	0,6
W20	20	6000	2,466	0 / -13	6	9	0,1	0,9
W22	22	6000	2,980	0 / -13	6	9	0,1	0,9
W24	24	6000	3,551	0 / -13	6	9	0,1	0,9
W25	25	6000	3,853	0 / -13	6	9	0,1	0,9
W28	28	6000	4,833	0 / -13	6	9	0,1	0,9
W30	30	6000	5,549	0 / -13	6	9	0,1	0,9
W32	32	6000	6,313	0 / -16	7	11	0,1	1,5
W35	35	6000	7,552	0 / -16	7	11	0,1	1,5
W40	40	6000	9,864	0 / -16	7	11	0,1	1,5
W45	45	6000	12,520	0 / -16	7	11	0,1	1,5
W50	50	6000	15,413	0 / -16	7	11	0,1	1,5
W60	60	6000	22,195	0 / -19	8	13	0,1	2,2
W70	70	6000	30,210	0 / -19	8	13	0,1	2,2
W80	80	6000	39,458	0 / -19	8	13	0,1	2,2

- ¹⁾ Durchmesserdifferenzmessung
- ²⁾ Messung analog DIN ISO 13012
- ³⁾ Randhärtetiefe
- ⁴⁾ Durchgehärtet möglich

- Werkstoff: z.B. Vergütungsstahl Cf53 / 1.1213
- Oberflächenhärte: 59 HRC min.

- 1) Diameter differential measurement
- 2) Measurement analog DIN ISO 13012
- 3) Surface hardening depth
- 4) Through-hardened possible

- Material: e.g. quenched and tempered steel Cf53 / 1.1213
- Surface hardness: 59 HRC min.

Präzisionswellen W (Empfohlene Gewindebohrungen)
Precision shafts W (Recommended threaded holes)

W

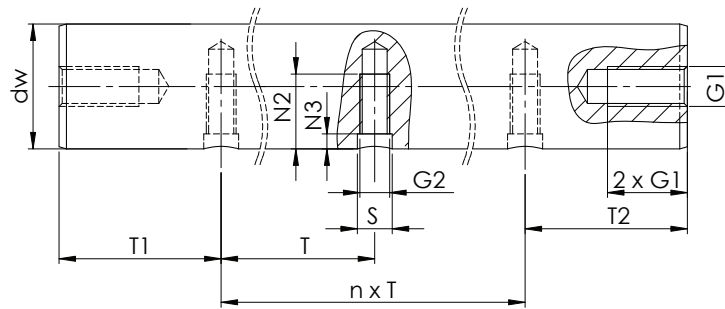

Abmessungen
 Dimensions (mm)

Typ Type	Radialgewinde Radial thread G2									Axialgewinde Axial thread G1									
	T			T1min / T2min		G2	N2	N3	S										
				Ziffer / code															
				01 ¹⁾	02 ²⁾	G2	N2	N3	S										
W8	-	-	-	-	-	-	-	-	-	M3	-	-	-	-	-	-	-	-	-
W10	-	-	-	-	-	-	-	-	-	M3	M4	-	-	-	-	-	-	-	-
W12	75	-	120	10	3xG1+G2	M4	7	2	5	-	M4	M5	-	-	-	-	-	-	
W14	-	-	-	-	-	-	-	-	-	-	M4	M5	M6	-	-	-	-	-	
W15	-	-	-	-	-	-	-	-	-	-	-	M5	M6	M8	-	-	-	-	
W16	75	100	150	15	3xG1+G2	M5	9	2,5	6	-	-	M5	M6	M8	-	-	-	-	
W18	-	-	-	-	-	-	-	-	-	-	-	-	M6	M8	M10	M12	-	-	
W20	-	-	150	15	3xG1+G2	M5	9	2,5	6	-	-	-	-	-	-	-	-	-	
W20	75	100	150	15	3xG1+G2	M6	11	3	7	-	-	-	M6	M8	M10	M12	-	-	
W24	-	-	-	-	-	-	-	-	-	-	-	-	-	M8	M10	M12	-	-	
W25	-	-	150	15	3xG1+G2	M6	11	3	7	-	-	-	-	-	-	-	-	-	
W25	75	120	150	15	3xG1+G2	M8	15	3	9	-	-	-	-	-	M10	M12	-	-	
W30	-	-	150	15	3xG1+G2	M6	11	3	7	-	-	-	-	-	-	-	-	-	
W30	100	150	200	20	3xG1+G2	M10	17	3,5	11	-	-	-	-	-	M10	M12	M16	-	
W32	-	-	-	-	-	-	-	-	-	-	-	-	-	-	M10	M12	M16	-	
W40	150	200	300	20	3xG1+G2	M10	19	4	11	-	-	-	-	-	M10	M12	M16	-	
W40	100	-	-	20	3xG1+G2	M12	21	4	13	-	-	-	-	-	M10	M12	M16	-	
W50	-	-	150	20	3xG1+G2	M10	19	4	11	-	-	-	-	-	-	-	-	-	
W50	-	200	300	20	3xG1+G2	M12	21	4	13	-	-	-	-	-	-	M12	M16	M20	
W50	100	-	-	20	3xG1+G2	M14	25	4	15	-	-	-	-	-	-	M12	M16	M20	
W60	-	-	-	-	-	-	-	-	-	-	-	-	-	-	-	-	M16	M20	M24
W80	-	-	-	-	-	-	-	-	-	-	-	-	-	-	-	-	M16	M20	M24

- 1) Welle ohne Axialgewinde
- 2) Welle mit Axialgewinde

- 1) Shaft without axial thread
- 2) Shaft with axial thread

Präzisionswellen, vorgebohrt

Precision shafts, predrilled

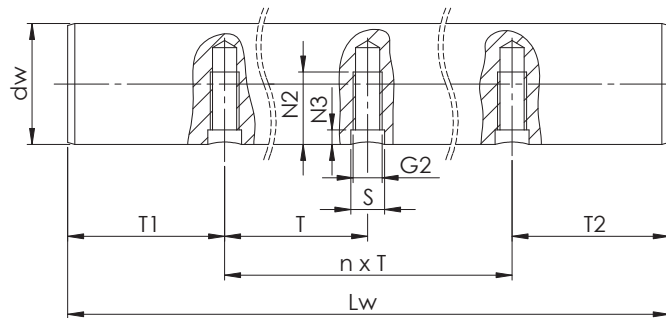

Abmessungen Dimensions (mm)		Anzahl Gewinde No. of threads							
Typ Type	dw	Lw	T	T1	G2	N2	N3	S	
W12A	12	6000	75	37,5	M4	7	2	5	80
W12B	12	6000	120	60	M4	7	2	5	50
W12C	12	6000	150	75	M4	7	2	5	40
W16A	16	6000	75	37,5	M5	9	2,5	6	80
W16B	16	6000	100	50	M5	9	2,5	6	60
W16C	16	6000	150	75	M5	9	2,5	6	40
W20A	20	6000	75	37,5	M6	11	3	7	80
W20B	20	6000	100	50	M6	11	3	7	60
W20C	20	6000	150	75	M6	11	3	7	40
W20D	20	6000	150	75	M5	9	2,5	6	40
W25A	25	6000	75	37,5	M8	15	3	9	80
W25B	25	6000	120	60	M8	15	3	9	50
W25C	25	6000	200	100	M8	15	3	9	30
W25D	25	6000	150	75	M6	11	3	7	40

- 1) Längtoleranz: ± 3 mm, Trennschnitt entgratet
- 2) Abstandstoleranz: $\pm 0,2$ mm, $T1 = T2$
- 3) Positionstoleranz Gewinde \varnothing ($\pm 0,2$ mm)

- 1) Length tolerance: ± 3 mm, separating cut deburred
- 2) Distance tolerance $\pm 0,2$ mm, $T1 = T2$
- 3) Positional tolerance of thread \varnothing ($\pm 0,2$ mm)

- Vorgebohrte Präzisionswellen in Fixlänge
- Speziell zum Einsatz für Tragschienen
- Verchromt oder korrosionsbeständig X90 / X46 siehe Bestellbeispiel:

WV16 mit Teilung 100 und Gewinde M5: WV16B
WKA25 mit Teilung 75 und Gewinde M8: WKA25A

- Predrilled precision shafts in fixed length
- Available for applications in shaft support rail units
- Chrome plated or stainless steel X90 / X46 see ordering designation:

WV16 with pitch 100 and thread M5: WV16B
WKA25 with pitch 75 and thread M8: WKA25A

Präzisionswellen, vorgebohrt Precision shafts, predrilled

W

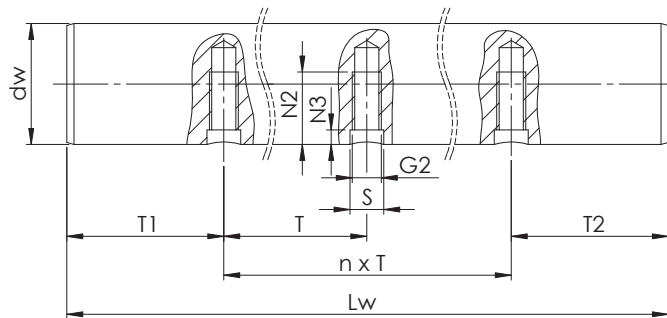

Abmessungen Dimensions (mm)

Anzahl Gewinde No. of threads

Typ Type	dw	Lw	T	T1	G2	N2	N3	S	
W30A	30	6000	100	50	M10	17	3,5	11	60
W30B	30	6000	150	75	M10	17	3,5	11	40
W30C	30	6000	200	100	M10	17	3,5	11	30
W30D	30	6000	150	75	M6	11	3	7	40
W40A	40	6000	150	75	M10	19	4	11	40
W40B	40	6000	200	100	M10	19	4	11	30
W40C	40	6000	300	150	M10	19	4	11	20
W40D	40	6000	100	50	M12	21	4	13	60
W50A	50	6000	150	75	M10	19	4	11	40
W50B	50	6000	200	100	M12	21	4	13	30
W50C	50	6000	300	150	M12	21	4	13	20
W50D	50	6000	100	50	M14	25	4	15	60
W60A	60	6000	300	150	M14	25	4	15	20
W80A	80	6000	300	150	M16	28	4	17	20

- 1) Längentoleranz: ± 3 mm, Trennschnitt entgratet
- 2) Abstandstoleranz: $\pm 0,2$ mm, $T1 = T2$
- 3) Positionstoleranz Gewinde \varnothing ($\pm 0,2$ mm)

- 1) Length tolerance: ± 3 mm, separating cut deburred
- 2) Distance tolerance $\pm 0,2$ mm, $T1 = T2$
- 3) Positional tolerance of thread \varnothing ($\pm 0,2$ mm)

- Vorgebohrte Präzisionswellen in Fixlänge
- Speziell zum Einsatz für Tragschienen
- Verchromt oder korrosionsbeständig X90 / X46 siehe Bestellbeispiel:

WV16 mit Teilung 100 und Gewinde M5: WV16B
WKA25 mit Teilung 75 und Gewinde M8: WKA25A

- Predrilled precision shafts in fixed length
- Available for applications in shaft support rail units
- Chrome plated or stainless steel X90 / X46 see ordering designation:

WV16 with pitch 100 and thread M5: WV16B
WKA25 with pitch 75 and thread M8: WKA25A

Präzisionswellen WV, verchromt

Precision shafts WV, chrome plated

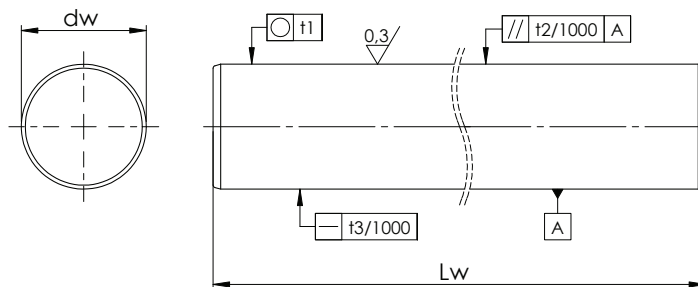

Abmessungen Dimensions (mm)		Gewicht Weight	Toleranz Tolerance	Rundheit Circularity	Parallelität ¹⁾ Parallelism	Geradheit ²⁾ Straightness	Rht (min) ³⁾ SHD (min)	
Typ Type	dw	Lw	Gew kg/m	ISO h7 µm	t1 µm	t2 µm	t3 mm	DIN ISO 13012 mm
WV6	6	6000	0,222	0 / -12	5	8	0,2	0,4
WV8	8	6000	0,394	0 / -15	6	9	0,2	0,4
WV10	10	6000	0,616	0 / -15	6	9	0,1	0,4
WV12	12	6000	0,888	0 / -18	8	11	0,1	0,6
WV14	14	6000	1,208	0 / -18	8	11	0,1	0,6
WV15	15	6000	1,387	0 / -18	8	11	0,1	0,6
WV16	16	6000	1,578	0 / -18	8	11	0,1	0,6
WV18	18	6000	1,997	0 / -18	8	11	0,1	0,6
WV20	20	6000	2,466	0 / -21	9	13	0,1	0,9
WV22	22	6000	2,980	0 / -21	9	13	0,1	0,9
WV24	24	6000	3,551	0 / -21	9	13	0,1	0,9
WV25	25	6000	3,853	0 / -21	9	13	0,1	0,9
WV28	28	6000	4,833	0 / -21	9	13	0,1	0,9
WV30	30	6000	5,549	0 / -21	9	13	0,1	0,9
WV32	32	6000	6,313	0 / -25	11	16	0,1	1,5
WV35	35	6000	7,552	0 / -25	11	16	0,1	1,5
WV40	40	6000	9,864	0 / -25	11	16	0,1	1,5
WV45	45	6000	12,520	0 / -25	11	16	0,1	1,5
WV50	50	6000	15,413	0 / -25	11	16	0,1	1,5
WV60	60	6000	22,195	0 / -30	13	19	0,1	2,2
WV70	70	6000	30,210	0 / -30	13	19	0,1	2,2
WV80	80	6000	39,458	0 / -30	13	19	0,1	2,2

- 1) Durchmesserdifferenzmessung
- 2) Messung analog DIN ISO 13012
- 3) Randhärte tiefe

- Werkstoff: z.B. Vergütungsstahl Cf53 / 1.1213
- Oberflächenhärte: 59 HRC min.
- Dicke Chromschicht: ca. 10 µm
- Schichthärte: ≥ 800 HV

- 1) Diameter differential measurement
- 2) Measurement analog DIN ISO 13012
- 3) Surface hardening depth

- Material: e.g. quenched and tempered steel Cf53 / 1.1213
- Surface hardness: 59 HRC min.
- Chrome layer thickness: approx. 10 µm
- Layer hardness: ≥ 800 HV

Präzisionswellen WKA, korrosionsbeständig X90

Precision shafts WKA, stainless steel X90

WKA

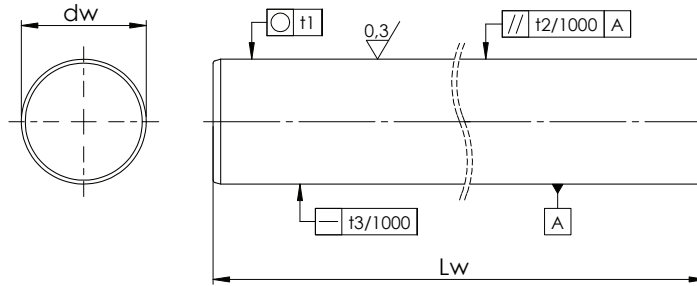

Abmessungen Dimensions (mm)		Gewicht Weight		Toleranz Tolerance	Rundheit Circularity	Parallelität ¹⁾ Parallelism	Geradheit ²⁾ Straightness	Rht (min) ³⁾ SHD (min)
Typ Type	dw	Lw	Gew kg/m	ISO h6 µm	t1 µm	t2 µm	t3 mm	DIN ISO 13012 mm
WKA4	4	2000	0,098	0 / -8	4	5	0,3	0,4 ⁴⁾
WKA5	5	3000	0,154	0 / -8	4	5	0,2	0,4 ⁴⁾
WKA6	6	6000	0,222	0 / -8	4	5	0,2	0,4
WKA8	8	6000	0,394	0 / -9	4	6	0,2	0,4
WKA10	10	6000	0,616	0 / -9	4	6	0,1	0,4
WKA12	12	6000	0,888	0 / -11	5	8	0,1	0,6
WKA14	14	6000	1,208	0 / -11	5	8	0,1	0,6
WKA15	15	6000	1,387	0 / -11	5	8	0,1	0,6
WKA16	16	6000	1,578	0 / -11	5	8	0,1	0,6
WKA18	18	6000	1,997	0 / -11	5	8	0,1	0,6
WKA20	20	6000	2,466	0 / -13	6	9	0,1	0,9
WKA22	22	6000	2,980	0 / -13	6	9	0,1	0,9
WKA24	24	6000	3,551	0 / -13	6	9	0,1	0,9
WKA25	25	6000	3,853	0 / -13	6	9	0,1	0,9
WKA28	28	6000	4,833	0 / -13	6	9	0,1	0,9
WKA30	30	6000	5,549	0 / -13	6	9	0,1	0,9
WKA32	32	6000	6,313	0 / -16	7	11	0,1	1,5
WKA35	35	6000	7,552	0 / -16	7	11	0,1	1,5
WKA40	40	6000	9,864	0 / -16	7	11	0,1	1,5
WKA45	45	6000	12,520	0 / -16	7	11	0,1	1,5
WKA50	50	6000	15,413	0 / -16	7	11	0,1	1,5
WKA60	60	6000	22,195	0 / -19	8	13	0,1	2,2

- 1) Durchmesserdifferenzmessung
- 2) Messung analog DIN ISO 13012
- 3) Randhärte tiefe
- 4) Durchgehärtet möglich

- Werkstoff: X90CrMoV18 / 1.4112
- Oberflächenhärte: 54 HRC min.
- Tragzahlminderung für Linearkugellager durch Minderhärte der Welle

- 1) Diameter differential measurement
- 2) Measurement analog DIN ISO 13012
- 3) Surface hardening depth
- 4) Through-hardened possible

- Material: X90CrMoV18 / 1.4112
- Surface hardness: 54 HRC min.
- Reduction of load rating for linear ball bearing because of less hardness

Präzisionswellen WKB, korrosionsbeständig X46
 Precision shafts WKB, stainless steel X46

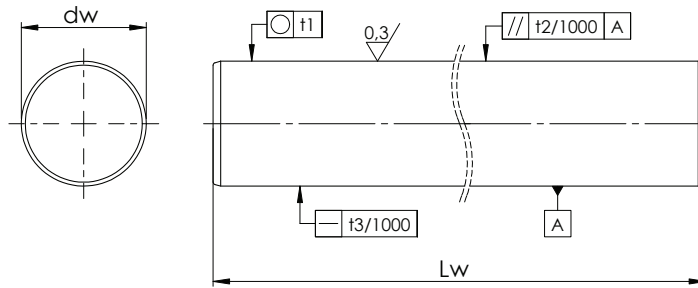

Abmessungen Dimensions (mm)		Gewicht Weight	Toleranz Tolerance	Rundheit Circularity	Parallelität ¹⁾ Parallelism	Geradheit ²⁾ Straightness	Rht (min) ³⁾ SHD (min)	
Typ Type	d_w	Lw	Gew kg/m	ISO h6 μm	t1 μm	t2 μm	t3 mm	DIN ISO 13012 mm
WKB3	3	2000	0,055	0 / -6	3	4	0,3	0,4 ⁴⁾
WKB4	4	2000	0,098	0 / -8	4	5	0,3	0,4 ⁴⁾
WKB5	5	3000	0,154	0 / -8	4	5	0,2	0,4 ⁴⁾
WKB6	6	6000	0,222	0 / -8	4	5	0,2	0,4
WKB8	8	6000	0,394	0 / -9	4	6	0,2	0,4
WKB10	10	6000	0,616	0 / -9	4	6	0,1	0,4
WKB12	12	6000	0,888	0 / -11	5	8	0,1	0,6
WKB14	14	6000	1,208	0 / -11	5	8	0,1	0,6
WKB15	15	6000	1,387	0 / -11	5	8	0,1	0,6
WKB16	16	6000	1,578	0 / -11	5	8	0,1	0,6
WKB18	18	6000	1,997	0 / -11	5	8	0,1	0,6
WKB20	20	6000	2,466	0 / -13	6	9	0,1	0,9
WKB22	22	6000	2,980	0 / -13	6	9	0,1	0,9
WKB24	24	6000	3,551	0 / -13	6	9	0,1	0,9
WKB25	25	6000	3,853	0 / -13	6	9	0,1	0,9
WKB28	28	6000	4,833	0 / -13	6	9	0,1	0,9
WKB30	30	6000	5,549	0 / -13	6	9	0,1	0,9
WKB32	32	6000	6,313	0 / -16	7	11	0,1	1,5
WKB35	35	6000	7,552	0 / -16	7	11	0,1	1,5
WKB40	40	6000	9,864	0 / -16	7	11	0,1	1,5
WKB45	45	6000	12,520	0 / -16	7	11	0,1	1,5
WKB50	50	6000	15,413	0 / -16	7	11	0,1	1,5
WKB60	60	6000	22,195	0 / -19	8	13	0,1	2,2

- 1) Durchmesserdiffferenzmessung
- 2) Messung analog DIN ISO 13012
- 3) Randhärte tiefe
- 4) Durchgehärtet

- Werkstoff: X46Cr13 / 1.4034
- Oberflächenhärte: 52 HRC min.
- Tragzahlminderung für Linearkugellager durch Minderhärte der Welle (siehe S. 7)

- 1) Diameter differential measurement
- 2) Measurement analog DIN ISO 13012
- 3) Surface hardening depth
- 4) Through-hardened

- Material: X46Cr13 / 1.4034
- Surface hardness: 52 HRC min.
- Reduction of load rating for linear ball bearing because of less hardness (see p. 7)

Präzisionswellen WZ, zöllig

Precision shafts WZ, inch

WZ

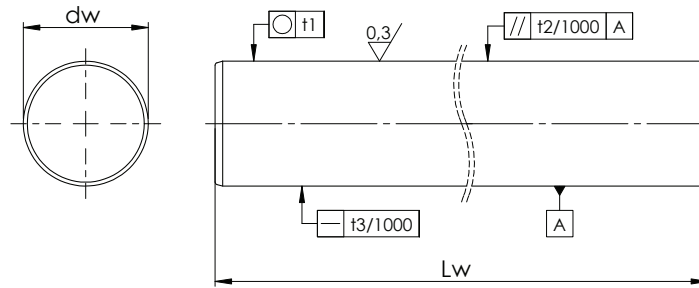

Abmessungen Dimensions (mm)			Gewicht Weight	Toleranz Tolerance	Rundheit Circularity	Parallelität ¹⁾ Parallelism	Geradheit ²⁾ Straightness	Rht (min) ³⁾ SHD (min)
Typ Type	dw	Lw	Gew kg/m	L µm	t1 µm	t2 µm	t3 mm	DIN ISO 13012 mm
WZ1/4	6,35	6000	0,249	-13 / -25	4	5	0,2	0,4
WZ3/8	9,525	6000	0,559	-13 / -25	4	6	0,2	0,4
WZ1/2	12,7	6000	0,994	-13 / -25	5	8	0,1	0,6
WZ5/8	15,875	6000	1,554	-13 / -25	5	8	0,1	0,6
WZ3/4	19,05	6000	2,237	-13 / -25	6	9	0,1	0,9
WZ7/8	22,225	6000	3,045	-13 / -25	6	9	0,1	0,9
WZ1	25,4	6000	3,978	-13 / -25	6	9	0,1	0,9
WZ1-1/8	28,575	6000	5,034	-13 / -25	6	9	0,1	0,9
WZ1-1/4	31,75	6000	6,215	-13 / -25	7	11	0,1	1,5
WZ1-3/8	34,925	6000	7,520	-15 / -28	7	11	0,1	1,5
WZ1-1/2	38,1	6000	8,950	-15 / -28	7	11	0,1	1,5
WZ2	50,8	6000	15,911	-15 / -33	7	11	0,1	1,5
WZ2-1/2	63,5	6000	24,860	-18 / -38	8	13	0,1	2,2
WZ3	76,2	6000	35,799	-20 / -43	8	13	0,1	2,2

- 1) Durchmesserdifferenzmessung
- 2) Messung analog DIN ISO 13012
- 3) Randhärte tiefe

- Werkstoff: z.B. Vergütungsstahl Cf53 / 1.1213
- Oberflächenhärte: 59 HRC min.
- Verchromt oder korrosionsbeständig X90 / X46 auf Anfrage

- 1) Diameter differential measurement
- 2) Measurement analog DIN ISO 13012
- 3) Surface hardening depth

- Material: e.g. quenched and tempered steel e.g. Cf53 / 1.1213
- Surface hardness: 59 HRC min.
- Chrome plated or stainless steel X90 / X46 upon request

Präzisionshohlwellen WH
Precision hollow shafts WH

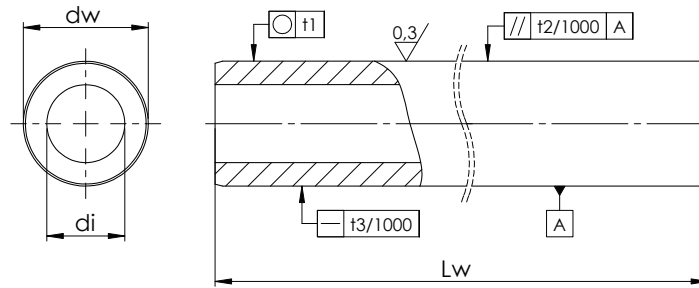

Abmessungen Dimensions (mm)			Gewicht Weight	Toleranz Tolerance	Rundheit Roundness	Parallelität ¹⁾ Parallelism	Geradheit ²⁾ Straightness	Rht (min) ³⁾ SHD (min)	
Typ Type	dw	Lw	di	Gew kg/m	ISO h6 µm	t1 µm	t2 µm	t3 mm	DIN ISO 13012 mm
WH12	12	6000	4	0,79	0 / -11	5	8	0,3	0,6
WH16	16	6000	7	1,28	0 / -11	5	8	0,3	0,6
WH20	20	6000	14	1,25	0 / -13	6	9	0,2	0,9
WH25	25	6000	15,6	2,35	0 / -13	6	9	0,2	0,9
WH30	30	6000	18,3	3,5	0 / -13	6	9	0,2	0,9
WH40	40	6000	28	4,99	0 / -16	7	11	0,1	1,5
WH50	50	6000	29,7	9,91	0 / -16	7	11	0,1	1,5
WH60	60	6000	36	14,2	0 / -19	8	13	0,1	2,2
WH80	80	6000	57	19,4	0 / -19	8	13	0,1	2,2

- 1) Durchmesserdifferenzmessung
- 2) Messung analog DIN ISO 13012
- 3) Randhärtetiefe

- Werkstoff: z.B. Vergütungsstahl C60 / 1.1221
- Oberflächenhärte: 59 HRC min.
- Toleranz h7 auf Anfrage

- 1) Diameter differential measurement
- 2) Measurement analog DIN ISO 13012
- 3) Surface hardening depth

- Material: e.g. quenched and tempered steel C60 / 1.1221
- Surface hardness: 59 HRC min.
- Tolerance h7 on request

	$w(x) = \frac{Fl^3}{3EI} \left[1 - \frac{3}{2} \cdot \frac{x}{l} + \frac{1}{2} \left(\frac{x}{l} \right)^3 \right]$ $f = \frac{Fl^3}{3EI} \quad \tan \alpha = \frac{Fl^2}{2EI}$ $F_B = F$
	$w(x) = \frac{ql^4}{8EI} \left[1 - \frac{4}{3} \cdot \frac{x}{l} + \frac{1}{3} \left(\frac{x}{l} \right)^4 \right]$ $f = \frac{ql^4}{8EI} \quad \tan \alpha = \frac{ql^3}{6EI}$ $F_B = q \cdot l$
	$w(x) = \frac{q_0 l^4}{120EI} \left[4 - 5 \cdot \frac{x}{l} + \left(\frac{x}{l} \right)^5 \right]$ $f = \frac{q_0 l^4}{30EI} \quad \tan \alpha = \frac{q_0 l^3}{24EI}$ $F_B = \frac{q_0 \cdot l}{2}$
	$w(x) = \frac{Fl^3}{16EI} \cdot \frac{x}{l} \left[1 - \frac{4}{3} \left(\frac{x}{l} \right)^2 \right] \quad x \leq \frac{l}{2}$ $f = \frac{Fl^3}{48EI} \quad \tan \alpha = \frac{Fl^2}{16EI}$ $F_A = F_B = \frac{F}{2}$
	$w_1(x_1) = \frac{Fl^3}{6EI} \cdot \frac{a}{l} \left(\frac{b}{l} \right)^2 \frac{x_1}{l} \left(1 + \frac{l}{b} - \frac{x_1^2}{ab} \right) \quad x_1 \leq a \quad f = \frac{Fl^3}{3EI} \left(\frac{a}{l} \right)^2 \left(\frac{b}{l} \right)^2 \quad \tan \alpha_1 = \frac{f}{2a} \left(1 + \frac{l}{b} \right)$ $w_2(x_2) = \frac{Fl^3}{6EI} \cdot \frac{b}{l} \left(\frac{a}{l} \right)^2 \frac{x_2}{l} \left(1 + \frac{l}{a} - \frac{x_2^2}{ab} \right) \quad x_2 \leq b \quad f_{\max} = f \frac{l+b}{3b} \sqrt{\frac{l+b}{3a}} \quad \tan \alpha_2 = \frac{f}{2b} \left(1 + \frac{l}{a} \right)$ $F_A = F \frac{b}{l} \quad F_B = F \frac{a}{l}$ <p>$x_{1\max} = a \sqrt{(l+b)/3a}$ für $a > b$ a und b für $a < b$ vertauschen</p>
	$w(x) = \frac{Fl^3}{2EI} \cdot \frac{x}{l} \left[\frac{a}{l} \left(1 - \frac{a}{l} \right) - \frac{1}{3} \left(\frac{x}{l} \right)^2 \right] \quad f = \frac{Fl^3}{2EI} \left(\frac{a}{l} \right)^2 \left(1 - \frac{4}{3} \cdot \frac{a}{l} \right) \quad \tan \alpha_1 = \frac{Fl^2}{2EI} \cdot \frac{a}{l} \left(1 - \frac{a}{l} \right)$ $x \leq a < l/2$ $w(x) = \frac{Fl^3}{2EI} \cdot \frac{a}{l} \left[\frac{x}{l} \left(1 - \frac{x}{l} \right) - \frac{1}{3} \left(\frac{a}{l} \right)^2 \right] \quad f_m = \frac{Fl^3}{8EI} \cdot \frac{a}{l} \left[1 - \frac{4}{3} \left(\frac{a}{l} \right)^2 \right] \quad \tan \alpha_2 = \frac{Fl^2}{2EI} \cdot \frac{a}{l} \left(1 - 2 \cdot \frac{a}{l} \right)$ $a \leq x \leq l/2$ $F_A = F_B = F$
	$w_1(x_1) = \frac{Fl^3}{2EI} \left[\frac{1}{3} \left(\frac{x_1}{l} \right)^3 - \frac{a}{l} \left(1 + \frac{a}{l} \right) \frac{x_1}{l} + \left(\frac{a}{l} \right)^2 \left(1 + \frac{2}{3} \cdot \frac{a}{l} \right) \right]$ $x_1 \leq a \quad f = \frac{Fl^3}{2EI} \left(\frac{a}{l} \right)^2 \left(1 + \frac{2}{3} \cdot \frac{a}{l} \right) \quad \tan \alpha_1 = \frac{Fl^2}{2EI} \cdot \frac{a}{l} \left(1 + \frac{a}{l} \right)$ $w_2(x_2) = \frac{Fl^3}{2EI} \cdot \frac{a}{l} \cdot \frac{x_2}{l} \left(1 - \frac{x_2}{l} \right) \quad x_2 \leq l \quad f_m = \frac{Fl^3}{8EI} \cdot \frac{a}{l} \quad \tan \alpha_2 = \frac{Fl^2}{2EI} \cdot \frac{a}{l}$ $F_A = F_B = F$
	$w_1(x_1) = \frac{Fl^3}{6EI} \cdot \frac{a}{l} \cdot \frac{x_1}{l} \left[1 - \left(\frac{x_1}{l} \right)^2 \right] \quad x_1 \leq l \quad f = \frac{Fl^3}{3EI} \left(\frac{a}{l} \right)^2 \left(1 + \frac{a}{l} \right) \quad \tan \alpha_A = \frac{Fl^2}{6EI} \cdot \frac{a}{l}$ $w_2(x_2) = \frac{Fl^3}{6EI} \cdot \frac{x_2}{l} \left[\frac{2a}{l} + \frac{3a}{l} \cdot \frac{x_2}{l} - \left(\frac{x_2}{l} \right)^2 \right] \quad x_2 \leq a \quad f_{\max} = \frac{Fl^3}{9\sqrt{3}EI} \cdot \frac{a}{l} \quad \tan \alpha_B = 2 \tan \alpha_A$ $F_A = F \frac{a}{l} \quad F_B = F \left(1 + \frac{a}{l} \right) \quad \tan \alpha = \frac{Fl^2}{6EI} \cdot \frac{a}{l} \left(2 + 3 \cdot \frac{a}{l} \right)$ <p>$x_{1\max} = l/\sqrt{3}$</p>
	$w(x) = \frac{ql^4}{24EI} \cdot \frac{x}{l} \left[1 - 2 \left(\frac{x}{l} \right)^2 + \left(\frac{x}{l} \right)^3 \right] \quad 0 \leq x \leq l \quad f_m = \frac{5ql^4}{384EI} \quad \tan \alpha = \frac{ql^3}{24EI}$ $F_A = \frac{q \cdot l}{2} \quad F_B = \frac{q \cdot l}{2}$
<p>$f, f_{\max}, f_m, w, w_1, w_2$ Durchbiegung / Bending (mm) $a, b, l, x_1, x_{1\max}, x_2$ Längen / Lengths (mm) E Elastizitätsmodul / Elasticity modulus (N/mm²) q, q_0 Streckenlast / Distributed load (N/mm)</p> <p>$\alpha, \alpha_1, \alpha_2, \alpha_A, \alpha_B$ Winkel / Angle (°) F, F_A, F_B Kräfte / Forces (N) I Flächenmoment 2. Grades / 2nd moment of area (mm⁴)</p>	

Linear-Komponenten

Linear Components

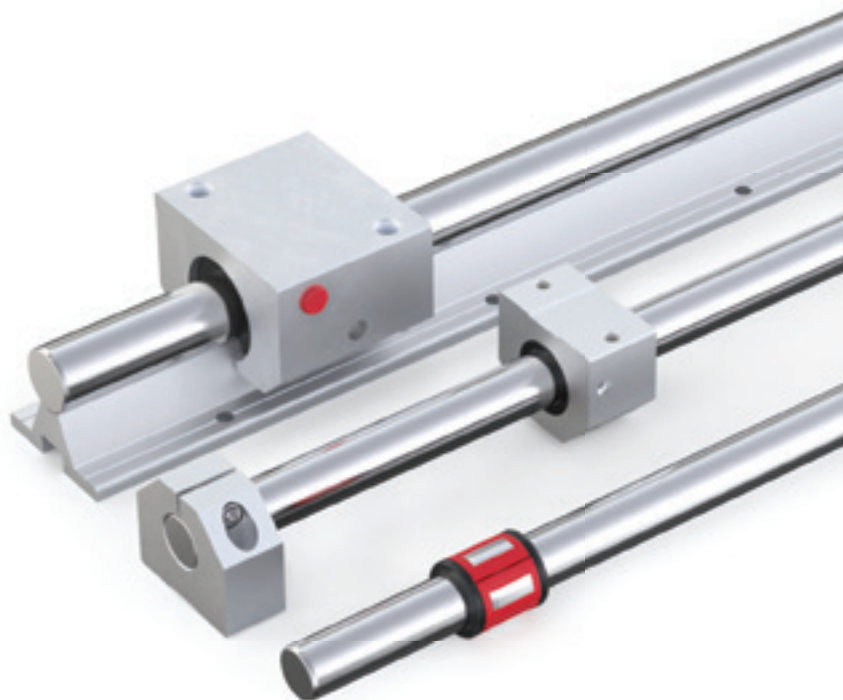





Produktübersicht

Product overview



LINEAR-KUGELLAGER / LINEAR BALL BEARINGS

Chapter A

	KH s. / p. 31	Linear-Kugellager, Kompakt-Baureihe Linear ball bearing, compact series		EXC / EXCE s. / p. 32	Linear-Kugellager, Kompakt-Baureihe mit/ohne Fluchtungsfehlerausgleich Linear ball bearing, compact series with / without self-alignment
	SBE s. / p. 33	Linear-Kugellager, Economy mit Fluchtungsfehlerausgleich Linear ball bearing, economy series with self alignment		SPM s. / p. 34	Linear-Kugellager, mit Fluchtungsfehlerausgleich Linear ball bearing, with self alignment
	MM s. / p. 35	Linear-Kugellager, Miniatur-Baureihe Linear ball bearing, miniature Series		SSEM s. / p. 36	Linear-Kugellager, mit Fluchtungsfehlerausgleich, hohe Tragzahl Linear ball bearing, with self alignment, high load capacity
	LME s. / p. 37	Linear-Kugellager, Standard-Baureihe, mit Kunststoffkäfig Linear ball bearing, standard series, plastic ball retainer		VD s. / p. 38	Vorsatz-Dichtungen Front wipers
	LMEF.. LMEF..L s. / p. 39-40	Linear-Kugellager, Rundflansch (..L : lange Ausführung) Linear ball bearing, round flange (..L : long type)		LMEK.. LMEK..L s. / p. 41-42	Linear-Kugellager, Quadratflansch (..L : lange Ausführung) Linear ball bearing, square flange (..L : long type)

LAUFROLLEN / TRACK ROLLERS

Chapter B

	LFR s. / p. 43	Profillaufrollen Track rollers		LFZ / LFE s. / p. 44	Zapfen, zentrisch und exzentrisch Bolts, concentric and excentric
---	--------------------------	--	---	--------------------------------	---

LINEARGEHÄUSE-EINHEITEN / LINEAR HOUSING UNITS





Chapter C

	EGC s. / p. 45	Lineargehäuse-Einheit, Kompakt-Ausführung, Einzel geschlossen Linear housing unit, compact series, single closed		ETGC s. / p. 46	Lineargehäuse-Einheit, Kompakt-Ausführung, Tandem geschlossen Linear housing unit, compact series, tandem closed
	EALGS s. / p. 47	Lineargehäuse-Einheit, Standard geschlossen Linear housing unit, standard closed		EALGSO s. / p. 48	Lineargehäuse-Einheit, Standard offen Linear housing unit, standard open
	EG s. / p. 49	Lineargehäuse-Einheit, Einzel geschlossen Linear housing unit, single closed		EGE s. / p. 50	Lineargehäuse-Einheit, Einzel geschlossen, einstellbar Linear housing unit, single open, adjustable
	EGO s. / p. 51	Lineargehäuse-Einheit, Einzel offen Linear housing unit, single open		EGOE s. / p. 52	Lineargehäuse-Einheit, Einzel offen, einstellbar Linear housing unit, single open, adjustable
	EGS s. / p. 53	Lineargehäuse-Einheit, Seitlich offen Linear housing unit, side open		EGSE s. / p. 54	Lineargehäuse-Einheit, Seitlich offen, einstellbar Linear housing unit, side open, adjustable
	ETG s. / p. 55	Lineargehäuse-Einheit, Tandem geschlossen Linear housing unit, tandem closed		ETGE s. / p. 56	Lineargehäuse-Einheit, Tandem geschlossen, einstellbar Linear housing unit, tandem closed, adjustable

	ETGO s. / p. 57	Lineargehäuse-Einheit, Tandem offen Linear housing unit, tandem open		ETGOE s. / p. 58	Lineargehäuse-Einheit, Tandem offen, einstellbar Linear housing unit, tandem open, adjustable
	ETGI s. / p. 59	Lineargehäuse-Einheit, Tandem geschlossen, vier Befestigungsbohrungen Linear housing unit, tandem closed, four fixing bores		ETGOI s. / p. 60	Lineargehäuse-Einheit, Tandem offen, vier Befestigungsbohrungen Linear housing unit, tandem open, four fixing bores
	EQSG s. / p. 61	Lineargehäuse-Einheit, Quattro geschlossen Linear housing unit, Quattro closed		EQSO s. / p. 62	Lineargehäuse-Einheit, Quattro offen Linear housing unit, Quattro open
	EFG s. / p. 63	Lineargehäuse-Einheit, Einzel Flansch Linear housing unit, single flange		ETFG s. / p. 64	Lineargehäuse-Einheit, Tandem Flansch Linear housing unit, tandem flange



WELLENBÖCKE / SHAFT SUPPORT BLOCKS

Chapter D

	EGWA s. / p. 65	Wellenbock, Standard-Baureihe Shaft support block, standard series		EGWH s. / p. 66	Wellenbock, Kompaktausführung Shaft support block, compact series
	EGWN s. / p. 67	Wellenbock Shaft support block		EFWB s. / p. 68	Flanschwellenbock Shaft support block with flange
	ETAC s. / p. 69	Wellenbock, Tandem, Kompaktausführung Shaft support block, tandem, compact series		ETA s. / p. 70	Wellenbock, Tandem, fest Shaft support block, tandem, fixed
	ETB s. / p. 71	Wellenbock, Tandem, beweglich Shaft support block, tandem, movable			

TRAGSCHIENEN / SHAFT SUPPORT RAIL UNITS



Chapter E

	ETSU s. / p. 72	Tragschienen, niedrige Ausführung Shaft support rail units, thin series		ETSN s. / p. 73	Tragschienen Shaft support rail units
	ETSS s. / p. 74	Tragschienen, Flache Ausführung Shaft support rail units, flat series			

NADELROLLEN-FLACHKÄFIGE / NEEDLE ROLLER FLAT CAGES

WEITERE PRODUKTE / FURTHER PRODUCTS

Chapter F

	R, R..ZW, RW s. / p. 75-77	Nadelrollen-Flachkäfige, Nadelrollen-Winkelflachkäfige Needle roller flat cages, Angular needle roller flat cages		Weitere Produkte Further products s. / p. 78	Anhang Appendix
---	--------------------------------------	---	---	---	--------------------

Linear-Kugellager Kompakt-Baureihe

Linear ball bearing Compact series

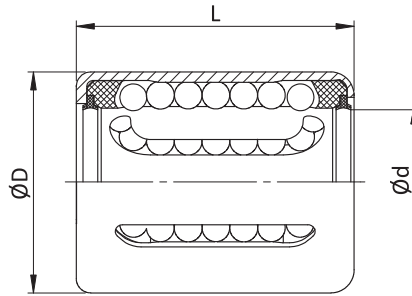

Abmessungen Dimensions (mm)

Gewicht Weight

Tragzahlen Load capacity

Typ Type	$\varnothing d$	$\varnothing D$	L	Gew g	dyn. C N	stat. C ₀ N
KH0622	6	12	22	7	400	239
KH0824	8	15	24	12	435	280
KH1026	10	17	26	14,5	500	370
KH1228	12	19	28	18,5	620	510
KH1428	14	21	28	20,5	620	520
KH1630	16	24	30	27,5	800	620
KH2030	20	28	30	32,5	950	790
KH2540	25	35	40	66	1990	1670
KH3050	30	40	50	95	2800	2700
KH4060	40	52	60	182	4400	4450
KH5070	50	62	70	252	5500	6300

Bestellbeispiel / Ordering designation



- die Tragzahlen gelten nur bei Einsatz von gehärteten (min. 670 HV) und geschliffenen Wellenlaufbahnen
- the load capacities are valid only if hardened (min. 670 HV) and ground shaft raceways are used



Linear-Kugellager mit / ohne Fluchtungsfehlerausgleich

Kompakt-Baureihe

EXC / EXCE

Linear ball bearing with / without self-alignment

compact series

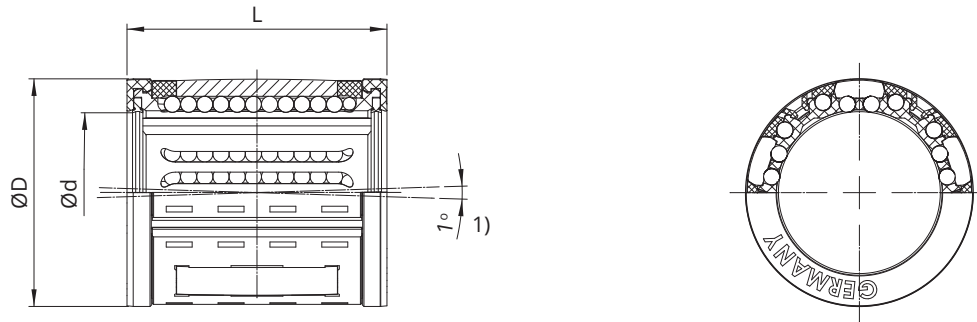

Abmessungen Dimensions (mm)

Tragzahlen Load capacity

Gewicht Weight

Typ Type	Ød	ØD	L	dyn. C N	stat. C ₀ N	Gew g
EXC12	12	19	28	866	757	11,4
EXC16	16	24	30	1224	1086	17,9
EXCE20	20	28	30	1094	855	14,8
EXC20	20	28	30	1362	1204	20,7
EXCE25	25	35	40	2061	1675	30,5
EXC25	25	35	40	2575	2397	44,3
EXCE30	30	40	50	2539	2221	39,8
EXC30	30	40	50	3423	3541	68,7

Bestellbeispiel / Ordering designation



- die Tragzahlen gelten nur bei Einsatz von gehärteten (min. 670 HV) und geschliffenen Wellenlaufbahnen
- 1) nur bei EXC(E) .. F
- the load capacities are valid only if hardened (min. 670 HV) and ground shaft raceways are used
- 1) only for EXC(E) .. F



Bild 1 / Fig. 1

Linear-Kugellager mit Fluchtungsfehlerausgleich

Economy-Baureihe, geschlossen und offen

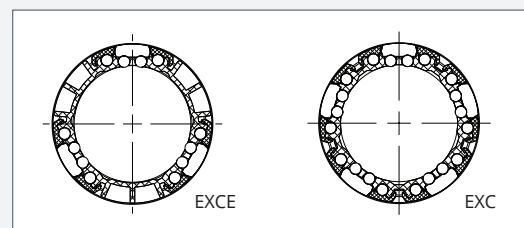

Linear ball bearing with self-alignment

Economy series, closed and open type

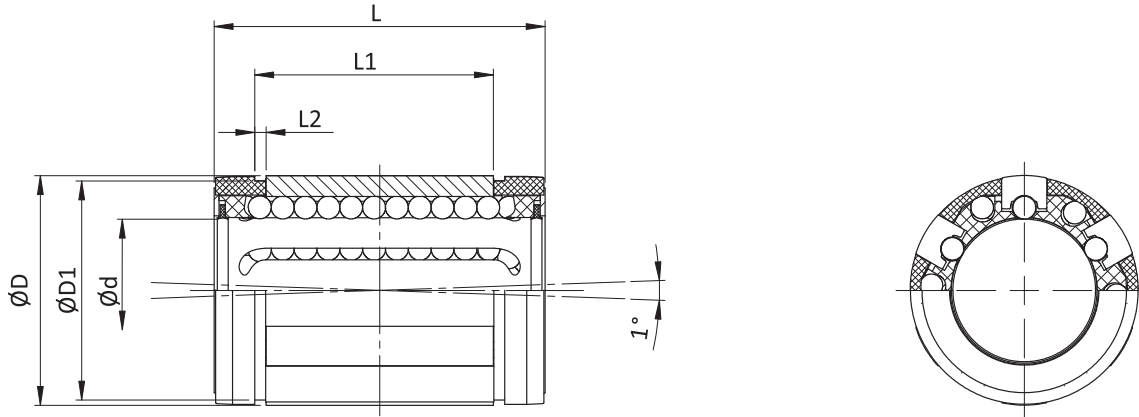

Abmessungen
Dimensions (mm)

Tragzahlen
Load capacity

Gewicht
Weight

Typ Type	Ød	ØD	L	L1	L2	ØD1	W	(°)	G	J	dyn. C N	stat. C ₀ N	Gew kg
SBE16	16	26	36	24,6	1,3	24,9	9,0	68	-	1,0	1140	710	0,028
SBE20	20	32	45	31,2	1,6	30,5	9,0	55	-	1,0	2280	1400	0,061
SBE25	25	40	58	43,7	1,85	38,5	11,5	57	1,5	1,5	4280	2740	0,122
SBE30	30	47	68	51,7	1,85	44,5	14,0	57	2,0	2,2	5020	3365	0,185
SBE40	40	62	80	60,3	2,15	58,5	19,5	56	1,5	2,7	8980	5460	0,360
SBE50	50	75	100	77,3	2,65	71,5	22,5	54	2,5	2,3	12965	7940	0,580

Bestellbeispiel / Ordering designation

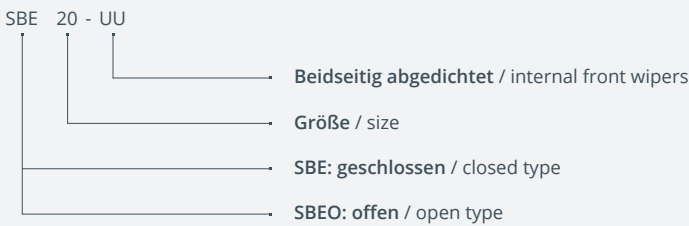

- die Tragzahlen gelten nur bei Einsatz von gehärteten (min. 670 HV) und geschliffenen Wellenlaufbahnen
- dyn. C auf Basis 50km
- the load capacities are valid only if hardened (min. 670 HV) and ground shaft raceways are used
- dyn. C based on 50km

SBE016, SBE020

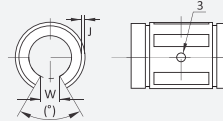

SBE25

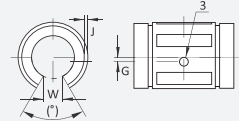

SBE30, SBE40

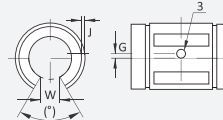

SBE50

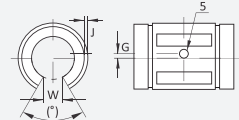



Linear-Kugellager mit Fluchtungsfehlerausgleich

Geschlossen und offen



Linear ball bearing with self-alignment

Closed and open type

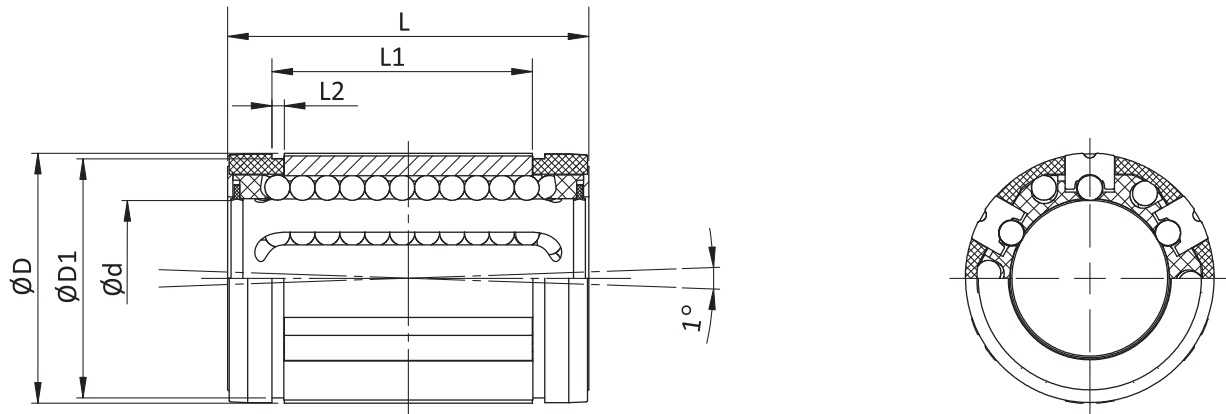

Abmessungen
Dimensions (mm)

Tragzahlen
Load capacity

Gewicht
Weight

Typ Type	Ød	ØD	L	L1	L2	ØD1	W	(°)	G	J	dyn. C N	stat. C ₀ N	Gew kg
SPM12	12	22	32	22,3	1,3	21,0	7,0	70	-	0,7	1060	1170	0,02
SPM16	16	26	36	24,6	1,3	24,9	9,8	70	-	1,0	1280	1410	0,03
SPM20	20	32	45	31,2	1,6	30,3	10,5	58	-	1,0	2100	2310	0,06
SPM25	25	40	58	43,7	1,85	37,5	13	60	1,5	1,5	4130	4540	0,13
SPM30	30	47	68	51,7	1,85	44,5	15,3	60	2,0	2,2	5020	5520	0,19
SPM40	40	62	80	60,3	2,15	59,0	21,4	58	1,5	2,7	8620	9480	0,36
SPM50	50	75	100	77,3	2,65	71,5	24	55	2,5	2,7	12060	13270	0,66

Bestellbeispiel / Ordering designation

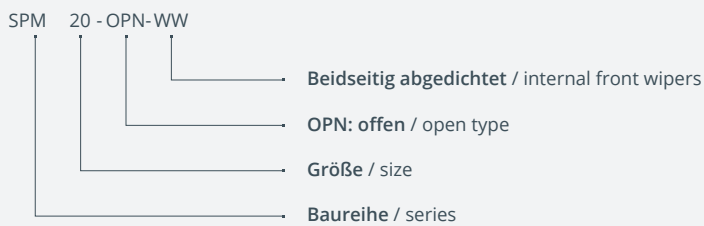

- die Tragzahlen gelten nur bei Einsatz von gehärteten (min. 670 HV) und geschliffenen Wellenlaufbahnen
- the load capacities are valid only if hardened (min. 670 HV) and ground shaft raceways are used

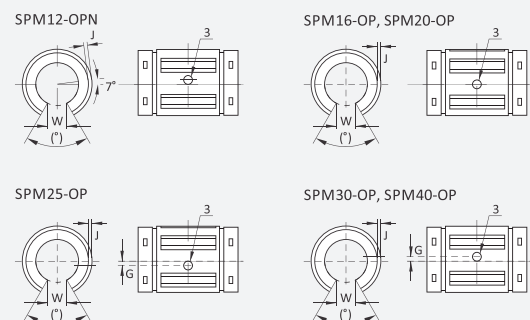

MM

Linear-Kugellager

Miniatur-Baureihe

Linear ball bearing
Miniature Series

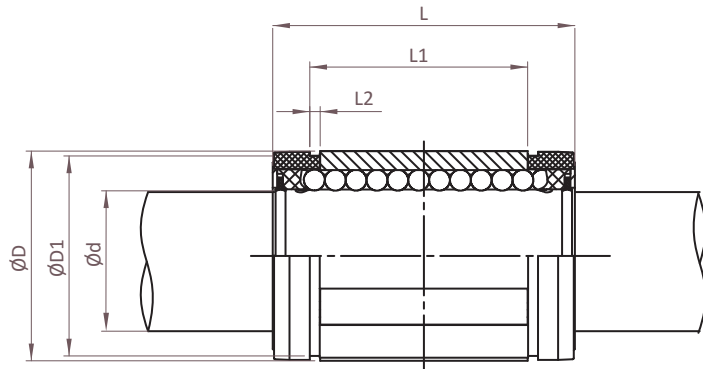
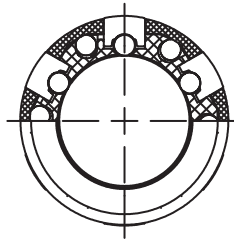

Abmessungen Dimensions (mm)

Kugelreihen No. of ball tracks

Tragzahlen Load capacity

Gewicht Weight

Typ Type	Ød	ØD	L	L1	L2 min.	n	dyn. C N	stat. C ₀ N	Gew kg
MM03	3	7	10	-	-	4	45	50	0,001
MM05	5	12	22	14,2	1,10	4	170	190	0,010
MM08	8	16	25	16,2	1,10	4	310	340	0,020
MM12	12	22	32	22,6	1,30	5	650	715	0,030

Bestellbeispiel / Ordering designation



- die Tragzahlen gelten nur bei Einsatz von gehärteten (min. 670 HV) und geschliffenen Wellenlaufbahnen
- Korrosionsbeständige Ausführung auf Anfrage
- Type MM03 nur ohne Abdichtung erhältlich
- the load capacities are valid only if hardened (min. 670 HV) and ground shaft raceways are used
- corrosion resistant types on request
- type MM03 without wipers only

THOMSON
Autorisierter Händler
Authorised Distributor

Linear-Kugellager mit Fluchtungsfehlerausgleich

Hohe Tragzahl, geschlossen und offen

SSEM

Linear ball bearing with self-alignment
High load capacity, closed and open type

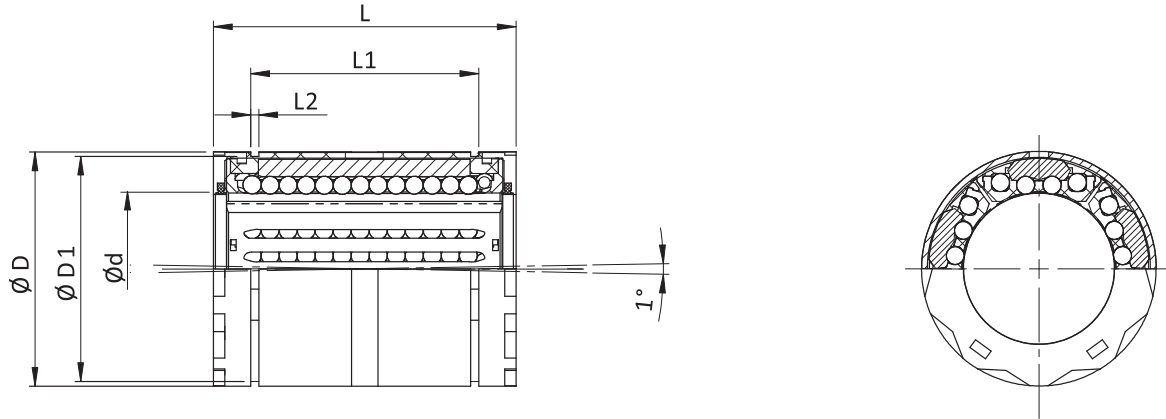

Abmessungen Dimensions (mm)

Tragzahlen Load capacity

Gewicht Weight

Typ Type	Ød	ØD	L	L1	L2	W	(°)	G	dyn. C N	stat. C ₀ N	Gew kg
SSEM16	16	26	36	24,6	1,3	9,0	70	0	2200	2400	0,03
SSEM20	20	32	45	31,2	1,6	10,0	50	0	4000	4400	0,07
SSEM25	25	40	58	43,7	1,85	12,5	60	1,5	6700	7300	0,13
SSEM30	30	47	68	51,7	1,85	13,7	55	2,0	8300	9100	0,21
SSEM40	40	62	80	60,3	2,15	19,0	54	1,5	13700	15000	0,39

Bestellbeispiel / Ordering designation



- die Tragzahlen gelten nur bei Einsatz von gehärteten (min. 670 HV) und geschliffenen Wellenlaufbahnen
- the load capacities are valid only if hardened (min. 670 HV) and ground shaft raceways are used

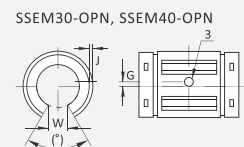
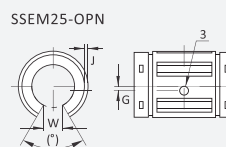
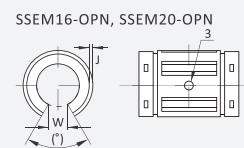

THOMSON
Autorisierter Händler
Authorised Distributor

Linear-Kugellager

Standard-Baureihe, mit Kunststoffkäfig



Linear ball bearing
Standard series, plastic ball retainer

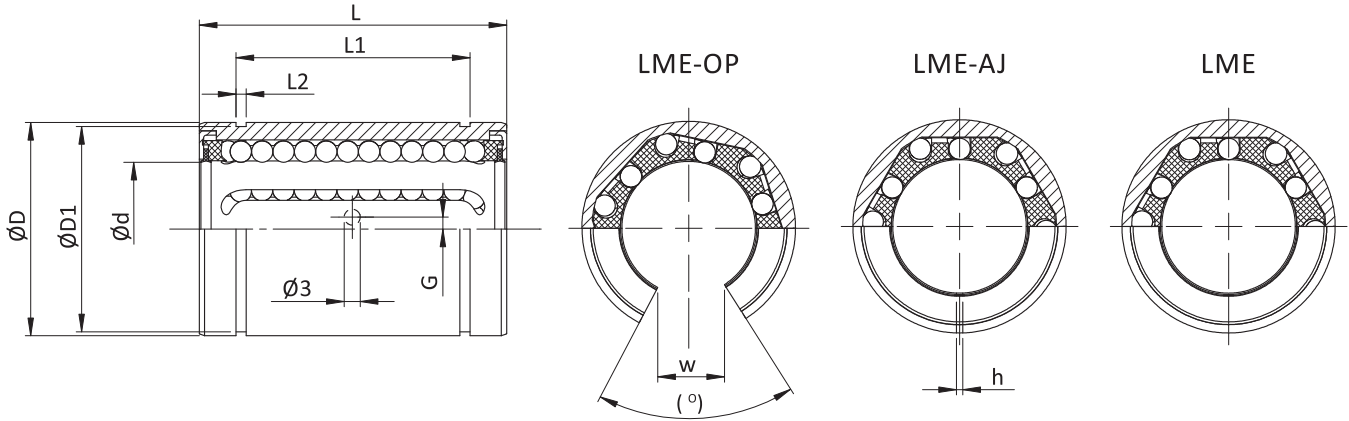

Abmessungen
Dimensions (mm)

Typ Type	Ød	ØD	L	L1	L2	ØD1	h	W	(°)	G	Tragzahlen Load capacity		Gewicht Weight
											dyn. C N	stat. C ₀ N	Gew kg
LME05	5	12	22	14,5	1,1	11,5	1,0	-	-	-	270	270	0,01
LME08	8	16	25	16,5	1,1	15,2	1,0	-	-	-	350	410	0,02
LME12	12	22	32	22,9	1,3	21,0	1,5	7,5	78	0	555	800	0,04
LME16	16	26	36	24,9	1,3	24,9	1,5	10,0	78	0	1045	910	0,06
LME20	20	32	45	31,5	1,6	30,3	2,0	10,0	60	0	1170	1400	0,09
LME25	25	40	58	44,1	1,85	37,5	2,0	12,5	60	1,5 ¹⁾	1330	1600	0,21
LME30	30	47	68	52,1	1,85	44,5	2,0	12,5	50	2,0	2120	2800	0,32
LME40	40	62	80	60,6	2,15	59,0	3,0	16,8	50	1,5	2920	4100	0,70
LME50	50	75	100	77,6	2,65	72,0	3,0	21,0	50	2,5	5195	8100	1,13
LME60	60	90	125	101,7	3,15	86,5	3,0	27,2	54	0 ²⁾	6390	10200	2,05

Bestellbeispiel / Ordering designation

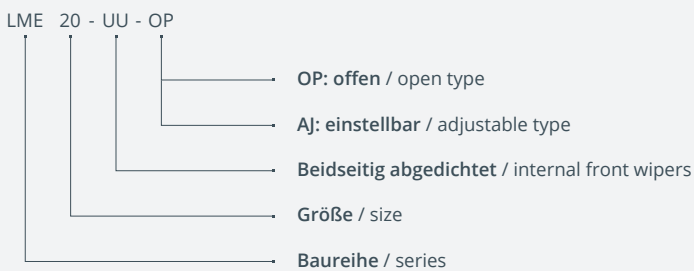

- die Tragzahlen gelten nur bei Einsatz von gehärteten (min. 670 HV) und geschliffenen Wellenlaufbahnen
- 1) die Fixierbohrung Ø 3 mm befindet sich unterhalb der Mitte
- 2) Fixierbohrung Ø 5 mm
- the load capacities are valid only if hardened (min. 670 HV) and ground shaft raceways are used
- 1) fixing bore Ø 3 mm below the middle line
- 2) fixing bore Ø 5 mm

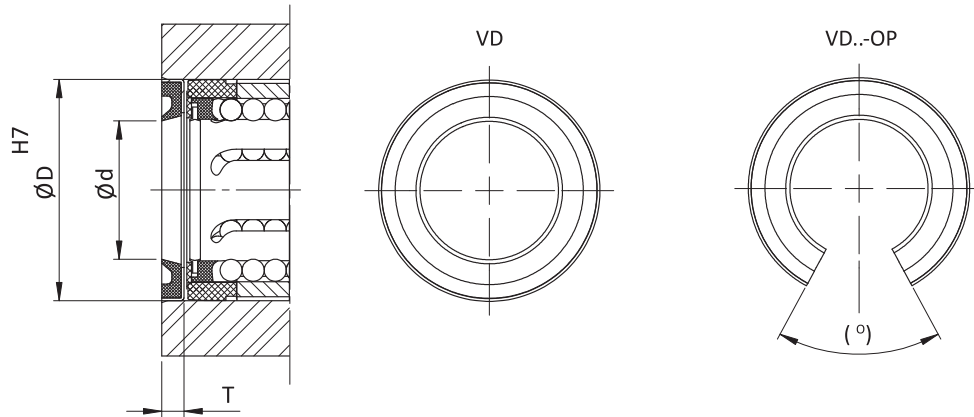

Abmessungen Dimensions (mm)

Typ Type	Ød	ØD	T	(°)
VD12	12	22	3,0	66
VD16	16	26	3,0	68
VD20	20	32	4,0	55
VD25	25	40	4,0	57
VD30	30	47	5,0	57
VD40	40	62	5,0	56
VD50	50	75	5,0	56

Bestellbeispiel / Ordering designation

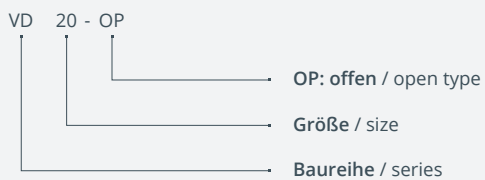

Linear-Kugellager

Rundflansch

Linear ball bearing

Round flange

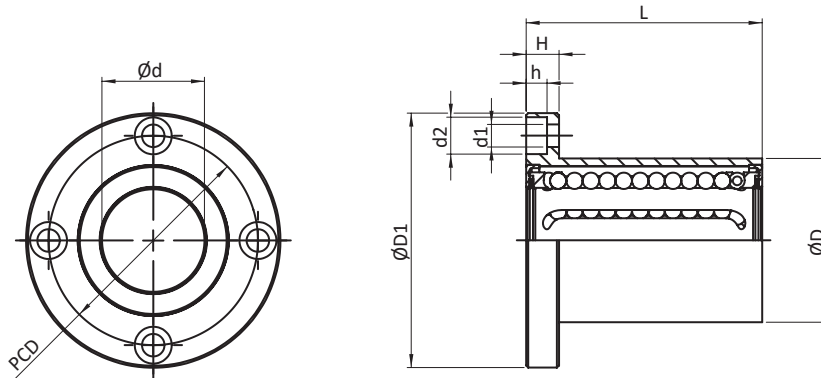

Abmessungen

Dimensions (mm)

Typ Type	Ød	ØD	ØD1	L ±0,3	H	PCD	d1xd2xh	Tragzahlen Load capacity		Gewicht Weight
								dyn. C N	stat. C ₀ N	Gew kg
LMEF-08	8	16	32	25	5	24	3,5x6x3,1	265	402	0.05
LMEF-12	12	22	42	32	6	32	4,5x7,5x4,1	510	784	0.08
LMEF-16	16	26	46	36	6	36	4,5x7,5x4,1	578	892	0.11
LMEF-20	20	32	54	45	8	43	5,5x9x5,1	862	1,370	0.19
LMEF-25	25	40	62	58	8	51	5,5x9x5,1	980	1,570	0.34
LMEF-30	30	47	76	68	10	62	6,6x11x6,1	1,570	2,740	0.56
LMEF-40	40	62	98	80	13	80	9x14x8,1	2,160	4,020	1.18
LMEF-50	50	75	112	100	13	94	9x14x8,1	3,820	7,940	1.75
LMEF-60	60	90	134	125	18	112	11x17x11,1	4,700	9,800	3.22

Bestellbeispiel / Ordering designation



- die Tragzahlen gelten nur bei Einsatz von gehärteten (min. 670 HV) und geschliffenen Wellenlaufbahnen

- the load capacities are valid only if hardened (min. 670 HV) and ground shaft raceways are used



Linear-Kugellager Rundflansch, lange Ausführung

LMEF..L

Linear ball bearing Round flange, long type

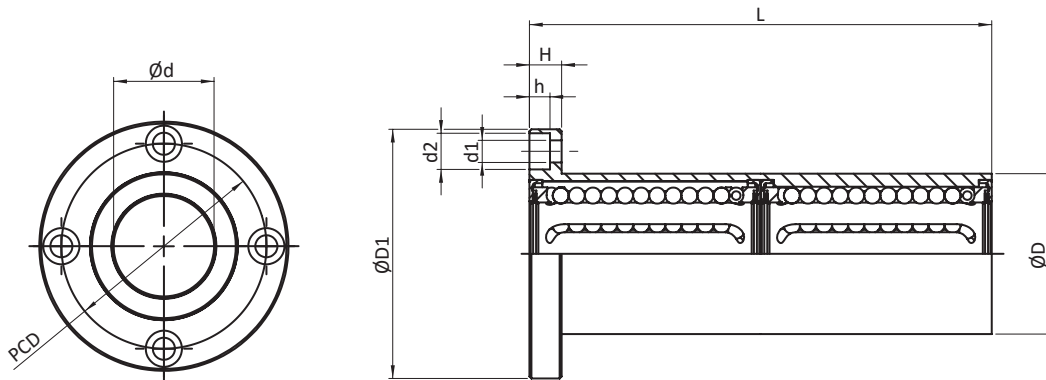

Abmessungen Dimensions (mm)

Typ Type	Ød	ØD	ØD1	L ±0,3	H	PCD	d1xd2xh	Tragzahlen Load capacity		Gewicht Weight
								dyn. C N	stat. C ₀ N	
LMEF-08-L	8	16	32	46	5	24	3,5x6x3,1	421	804	0.06
LMEF-12-L	12	22	42	61	6	32	4,5x7,5x4,1	813	1,570	0.11
LMEF-16-L	16	26	46	68	6	36	4,5x7,5x4,1	921	1,780	0.16
LMEF-20-L	20	32	54	80	8	43	5,5x9x5,1	1,370	2,740	0.26
LMEF-25-L	25	40	62	112	8	51	5,5x9x5,1	1,570	3,140	0.54
LMEF-30-L	30	47	76	123	10	62	6,6x11x6,1	2,500	5,490	0.82
LMEF-40-L	40	62	98	151	13	80	9x14x8,1	3,430	8,040	1.81
LMEF-50-L	50	75	112	192	13	94	9x14x8,1	6,080	15,900	2.82
LMEF-60-L	60	90	134	209	18	112	11x17x11,1	7,550	20,000	4.92

Bestellbeispiel / Ordering designation

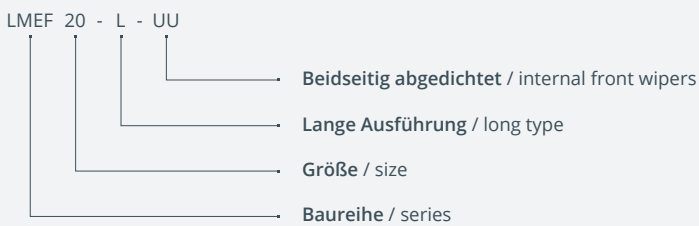

- die Tragzahlen gelten nur bei Einsatz von gehärteten (min. 670 HV) und geschliffenen Wellenlaufbahnen
- the load capacities are valid only if hardened (min. 670 HV) and ground shaft raceways are used

Linear-Kugellager
 Quadratflansch

Linear ball bearing
 Square flange

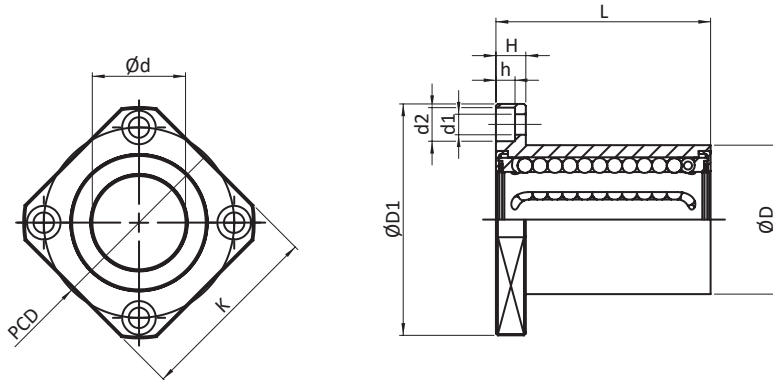

Abmessungen

Dimensions (mm)

Typ Type	$\varnothing d$	$\varnothing D$	K	L $\pm 0,3$	H	PCD	d1xd2xh	Tragzahlen Load capacity		Gewicht Weight
								dyn. C N	stat. C ₀ N	Gew kg
LMEK-08	8	16	25	25	5	24	3,5x6x3,1	265	402	0.05
LMEK-12	12	22	32	32	6	32	4,5x7,5x4,1	510	784	0.08
LMEK-16	16	26	35	36	6	36	4,5x7,5x4,1	578	892	0.11
LMEK-20	20	32	42	45	8	43	5,5x9x5,1	862	1,370	0.19
LMEK-25	25	40	50	58	8	51	5,5x9x5,1	980	1,570	0.34
LMEK-30	30	47	60	68	10	62	6,6x11x6,1	1,570	2,740	0.56
LMEK-40	40	62	75	80	13	80	9x14x8,1	2,160	4,020	1.18
LMEK-50	50	75	88	100	13	94	9x14x8,1	3,820	7,940	1.75
LMEK-60	60	90	106	125	18	112	11x17x11,1	4,700	9,800	3.22

Bestellbeispiel / Ordering designation

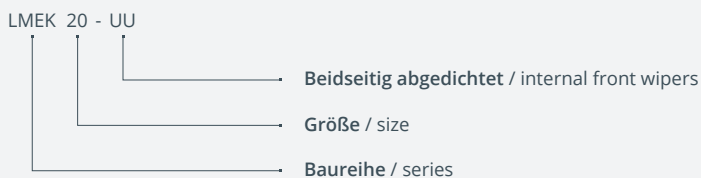

- die Tragzahlen gelten nur bei Einsatz von gehärteten (min. 670 HV) und geschliffenen Wellenlaufbahnen
- the load capacities are valid only if hardened (min. 670 HV) and ground shaft raceways are used



Linear-Kugellager Quadratflansch, lange Ausführung

LMEK..L

Linear ball bearing
Square flange, long type

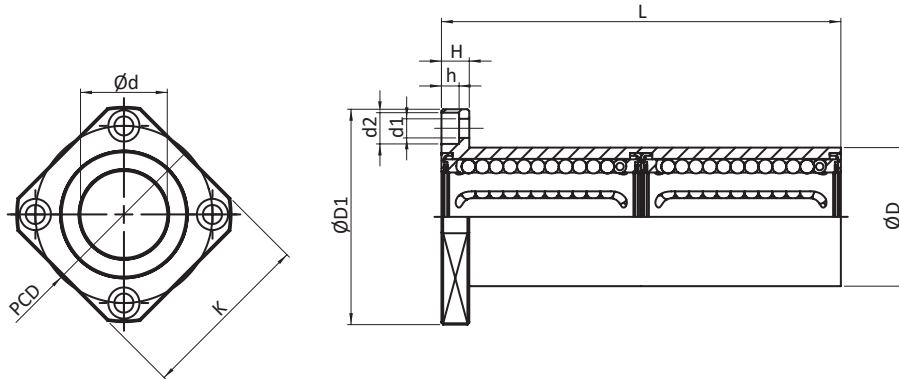

Abmessungen Dimensions (mm)

Tragzahlen Load capacity

Gewicht Weight

Typ Type	$\varnothing d$	$\varnothing D$	K	L $\pm 0,3$	H	PCD	d1xd2xh	dyn. C N	stat. C ₀ N	Gew kg
LMEK-08-L	8	16	25	46	5	24	3,5x6x3,1	421	804	0.06
LMEK-12-L	12	22	32	61	6	32	4,5x7,5x4,1	813	1,570	0.11
LMEK-16-L	16	26	35	68	6	36	4,5x7,5x4,1	921	1,780	0.16
LMEK-20-L	20	32	42	80	8	43	5,5x9x5,1	1,370	2,740	0.26
LMEK-25-L	25	40	50	112	8	51	5,5x9x5,1	1,570	3,140	0.54
LMEK-30-L	30	47	60	123	10	62	6,6x11x6,1	2,500	5,490	0.82
LMEK-40-L	40	62	75	151	13	80	9x14x8,1	3,430	8,040	1.81
LMEK-50-L	50	75	88	192	13	94	9x14x8,1	6,080	15,900	2.82
LMEK-60-L	60	90	106	209	18	112	11x17x11,1	7,550	20,000	4.92

Bestellbeispiel / Ordering designation

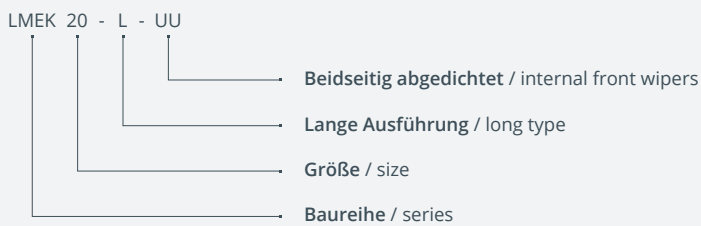

- die Tragzahlen gelten nur bei Einsatz von gehärteten (min. 670 HV) und geschliffenen Wellenlaufbahnen
- the load capacities are valid only if hardened (min. 670 HV) and ground shaft raceways are used

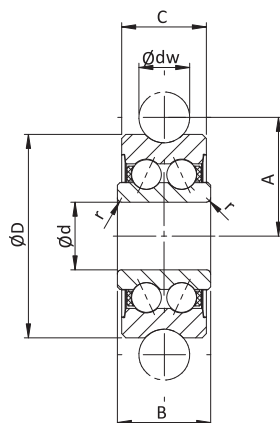
Abmessungen
 Dimensions (mm)

Gewicht
 Weight

Tragzahlen
 Load capacity

Max. Belastung
 Limit loads

empfohlene Zapfen
 suggested bolts

Typ Type	dw	d	D	C	B -0.12	A	r	Gew g	C_w N	C_{0w} N	F_{rz} N	F_{0rz} N	
LFR50/5-4 KDD	4	5	16	7	8	9	0,20	9	1.200	860	1.300	1.780	LFZ5, LFE5
LFR50/5-6 KDD	6	5	17	7	8	10,5	0,20	10	1.270	820	1.300	1.780	LFZ5, LFE5
LFR50/8-6 KDD	6	8	24	11	11	14	0,30	20	3.670	2.280	1.300	4.560	LFZ8, LFE8
LFR5201-10 KDD	10	12	35	15,9	15,9	20,65	0,30	66	8.500	5.100	5.100	10.200	LFZ12, LFE12
LFR5301-10 KDD	10	12	42	19	19	24	0,60	135	13.000	7.700	7.500	14.200	LFZ12/M12, LFE12/M12
LFR5302-10 KDD	10	15	47	19	19	26,65	1,00	170	16.200	9.200	6.200	18.400	LFZ15, LFE15
LFR5201-12 KDD	12	12	35	15,9	15,9	21,75	0,30	66	8.400	5.000	5.100	10.000	LFZ12x45A1, LFE12x45A1
LFR5204-16 KDD	16	20	52	20,6	22,6	31,5	0,60	195	16.800	9.500	12.100	16.600	LFZ20x67A1, LFE20x67A1
LFR5206-20 KDD	20	25	72	23,8	25,8	41	0,60	435	29.500	16.600	20.700	33.200	LFZ25x82A1, LFE25x82A1
LFR5206-25 KDD	25	25	72	23,8	25,8	43,5	0,60	425	29.200	16.400	23.100	32.800	LFZ25x82A1, LFE25x82A1
LFR5207-30 KDD	30	30	80	27	29	51	1,00	600	38.000	20.800	21.400	36.200	LFZ30x95A1, LFE30x95A1
LFR5208-40 KDD	40	40	98	36	38	62,5	1,00	1100	54.800	29.000	55.000	58.000	LFZ40x105A1, LFE40x105A1
LFR5308-50 KDD	50	40	110	46	46	72,5	1,10	1250	53.000	39.500	69.000	79.000	LFZ40x115A1, LFE40x115A1

Bestellbeispiel / Ordering designation

LFR 5201 - 10 - KDD



- Außendurchmesser ≥ 52 mm : Schmierbohrung im Innenring
- weitere Typen auf Anfragen
- outer diameter ≥ 52 mm : lubrication hole on inner ring
- other types on request



Zapfen Zentrisch und Exzentrisch

LFZ / LFE

Bolts Concentric and excentric

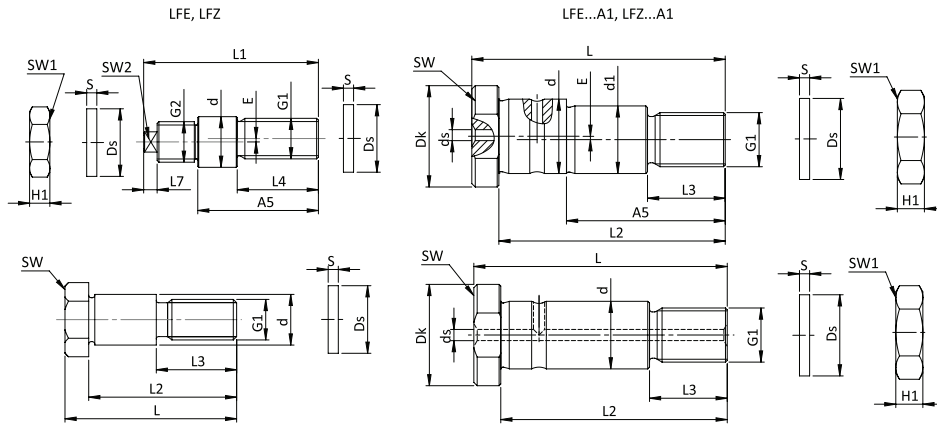

Abmessungen Dimensions (mm)

Gewicht Weight

Typ Type	L	L1	L2	L3	L4	L7	A5	d	d1	Dk	G1	G2	H1	S	Ds	ds	E	SW	SW1	SW2	Gew g
LFZ5, LFE5	19,5	20,5	16	9,5	9	-	15	5	-	-	M4	M4	2,9	-	-	-	0,5	3	7	2	10
LFZ8, LFE8	28,3	33,2	24,3	15	13,7	3,5	22	8	-	-	M8	M8x0,75	4	1	14	-	1	12	13	5	20
LFZ12, LFE12	43	50	36	22	19,5	5	33,5	12	-	-	M10	M10	8,4	1,8	21	-	1	17	17	6	40
LFZ12/M12, LFE12/M12	50,8	57	43,8	24	24	5	41	12	-	-	M12	M12	6,5	1,8	19	-	1	17	17	6	60
LFZ15, LFE15	50,8	57	43,8	26	24	5	41	15	-	-	M12	M12	6,5	1,8	21	-	1	19	19	6	60
LFZ12x45A1, LFE12x45A1	50	-	45	16	-	-	30	12	10	20	M10x1,5	-	8	2	21	5,9	0,75	17	17	-	40
LFZ20x67A1, LFE20x67A1	75	-	67	23	-	-	45	20	17	30	M16x1,5	-	13	3	30	5,9	1	27	24	-	200
LFZ25x82A1, LFE25x82A1	92	-	82	30	-	-	57	25	22	40	M20x1,5	-	16	3	37	5,9	1	36	30	-	400
LFZ30x95A1, LFE30x95A1	107	-	95	32	-	-	67	30	27	45	M24x1,5	-	19	4	44	5,9	1	41	36	-	620
LFZ40x107A1, FE40x107A1	117	-	107	42	-	-	72	40	36	55	M30x1,5	-	24	4	56	5,9	1	46	46	-	1100
LFZ40x115A1, LFE40x115A1	125	-	115	42	-	-	72	40	36	55	M30x1,5	-	24	4	56	5,9	1	46	46	-	1200

Lineargehäuse-Einheit

Kompaktausführung, einzel geschlossen

Linear housing unit

Compact series, single closed

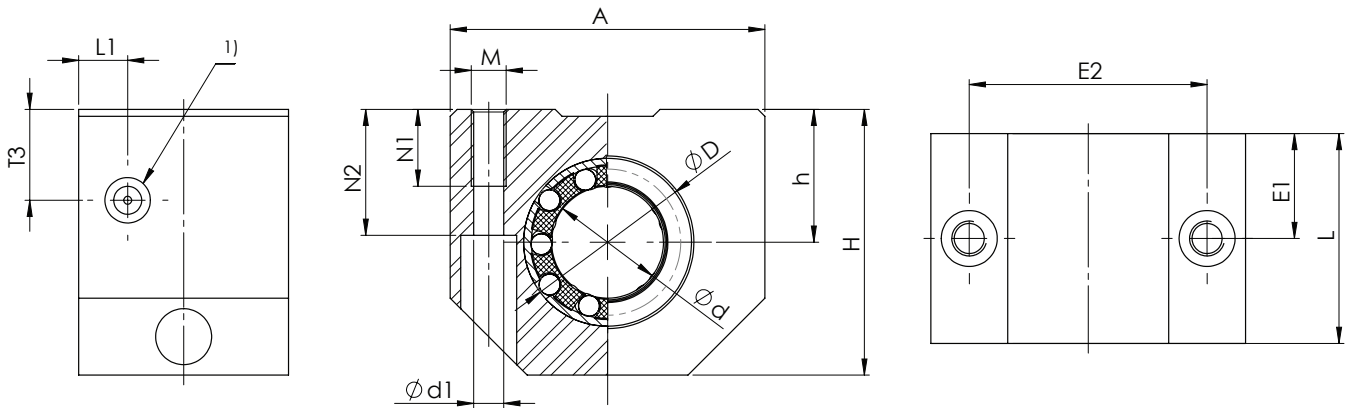

Abmessungen Dimensions (mm)

Gewicht Weight

Typ Type	Ød	ØD	H	h +0,01 -0,02	A	L	L1	T3	E1	E2 ±0,15	N1	N2	Ød1	M	Gew kg
EGC06	6	12	27	13	32	22	4	9	11	23	9	13	3,4	M4	0,04
EGC08	8	15	27	14	32	24	6	9	12	23	9	13	3,4	M4	0,05
EGC10	10	17	33	16	40	26	6	11	13	29	11	16	4,3	M5	0,07
EGC12	12	19	33	17	40	28	6	11	14	29	11	16	4,3	M5	0,09
EGC14	14	21	36,5	18	43	28	6	13	14	34	11	18	4,3	M5	0,10
EGC16	16	24	38	19	45	30	7	13	15	34	11	18	4,3	M5	0,13
EGC20	20	28	45	23	53	30	7	15	15	40	13	22	5,3	M6	0,15
EGC25	25	35	54	27	62	40	8	17,5	20	48	18	26	6,6	M8	0,30
EGC30	30	40	60	30	67	50	8	18	25	53	18	29	6,6	M8	0,46
EGC40	40	52	76	39	87	60	9	23	30	69	22	38	8,4	M10	0,88
EGC50	50	62	92	47	103	70	9	28	35	82	26	46	10,5	M12	1,25

Bestellbeispiel / Ordering designation

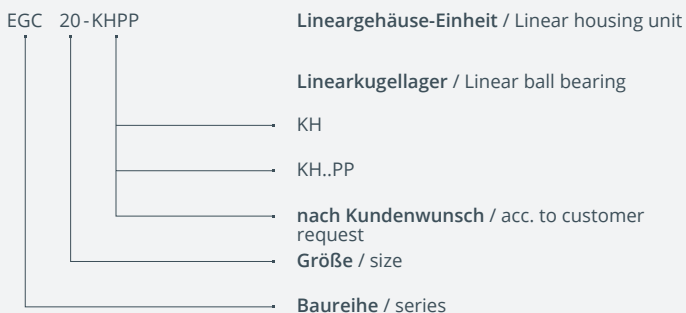

- Befestigungsschrauben DIN 912-8.8, Federring DIN 7980
- Gewichtsangabe mit Linearkugellager
- Tragzahlen nach Spezifikation des Linearkugellagers
- Schmierbohrung M8x1
- 1) Schmiernippel DIN 3405
- fixing screws acc. DIN 912-8.8, spring washers acc. DIN 7980
- weight including linear ball bearing
- load ratings according to the specification of the linear ball bearing
- lubrication bore M8x1
- 1) Grease nipple DIN 3405



Lineargehäuse-Einheit

Kompaktausführung, Tandem geschlossen

ETGC

Linear housing unit

Compact series, tandem closed

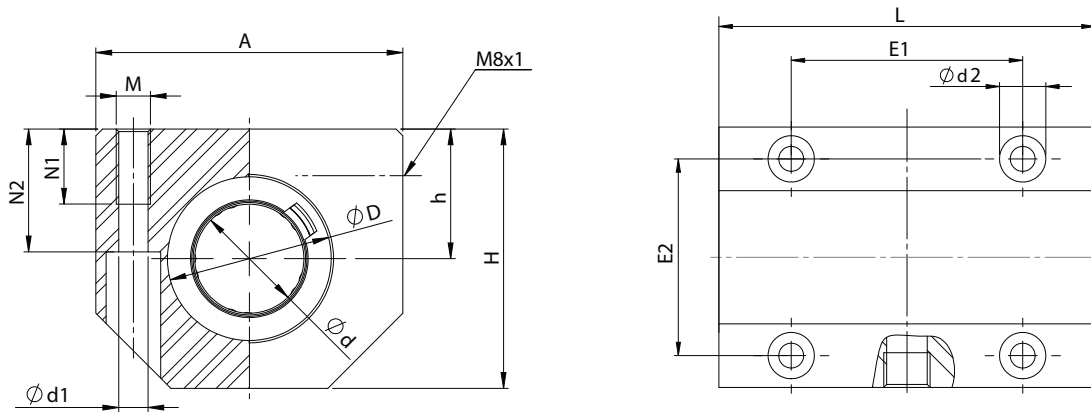

Abmessungen

Dimensions (mm)

Gewicht

Weight

Typ Type	Ød	ØD	H	h +0,01 -0,02	A	L	E1 ±0,15	E2 ±0,15	E3	N1	N2	Ød1	M	Gew kg
ETGC12	12	19	33	17	40	60	35	29	30,0	11	16	4,3	M5	0,18
ETGC16	16	24	38	19	45	65	40	34	32,5	11	18	4,3	M5	0,27
ETGC20	20	28	45	23	53	65	45	40	32,5	13	22	5,3	M6	0,32
ETGC25	25	35	54	27	62	85	55	48	42,5	18	26	6,6	M8	0,66
ETGC30	30	40	60	30	67	105	70	53	52,5	18	29	6,6	M8	0,95
ETGC40	40	52	76	39	87	125	85	69	62,5	22	38	8,4	M10	1,82
ETGC50	50	62	92	47	103	145	100	82	72,5	26	46	10,5	M12	2,52

Bestellbeispiel / Ordering designation

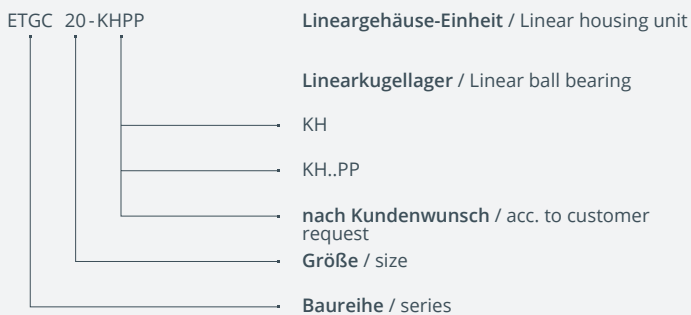

- Befestigungsschrauben DIN 912-8.8, Federring DIN 7980
- Gewichtsangabe mit Linearballlager
- Tragzahlen nach Spezifikation des Linearballagers
- Schmierbohrung M8x1
- fixing screws acc. DIN 912-8.8, spring washers acc. DIN 7980
- weight including linear ball bearing
- load ratings according to the specification of the linear ball bearing
- lubrication bore M8x1



Lineargehäuse-Einheit

Standard offen

EALGSO

Linear housing unit

Standard open

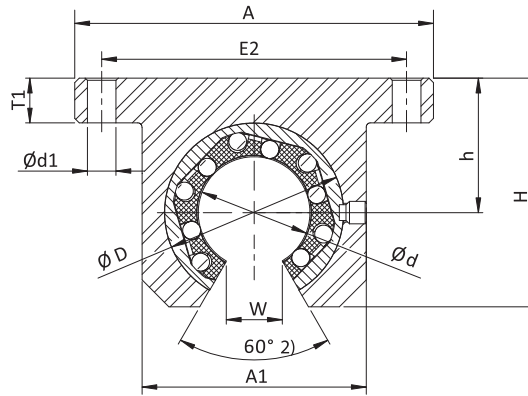
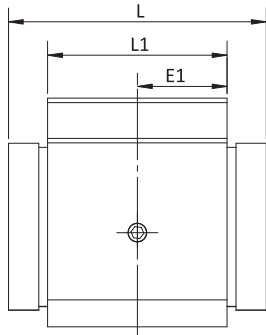

Abmessungen Dimensions (mm)

Gewicht Weight

Typ Type	Ø d	Ø D	H	h ±0,015	A	A1	L	L1	T1	E1	E2 ±0,15	W 1)	Ø d1	Gew kg
EALGSO12	12	22	28	18	52	30	32	20	6	10	42	7,5	5,3	0,09
EALGSO16	16	26	33,5	22	56	34	36	22	7	11	46	10	5,3	0,12
EALGSO20	20	32	42	25	70	40	45	28	8	14	58	10	6,4	0,25
EALGSO25	25	40	51	30	80	50	58	40	10	20	68	12,5	6,4	0,49
EALGSO30	30	47	60	35	88	58	68	48	10	24	76	12,5	6,4	0,78
EALGSO40	40	62	77	45	108	74	80	56	12	28	94	16,8	8,4	1,28
EALGSO50	50	75	93	50	135	96	100	72	12	36	116	21	10,5	1,70

Bestellbeispiel / Ordering designation

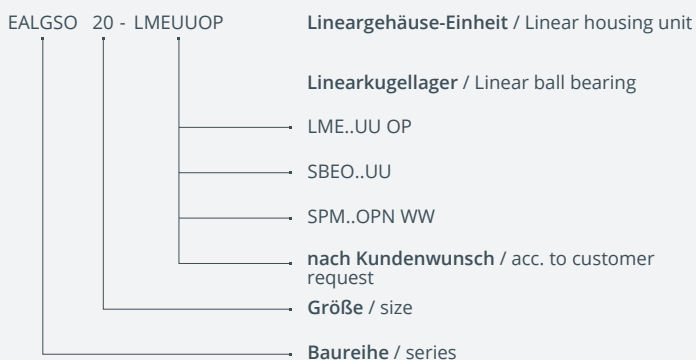

- Befestigungsschrauben DIN 912-8.8, Federring DIN 7980
- Befestigung des Lagers im Gehäuse mit Fixierschraube
- Gewichtsangabe mit Linearkugellager
- Tragzahlen nach Spezifikation des Linearkugellagers
- 1) Werte der Baureihe LME..UUOP
- 2) Winkel des Gehäuses; Winkel des verwendeten Linearkugellagers beachten
- fixing screws acc. DIN 912-8.8, spring washers acc. DIN 7980
- bearing fixing in the housing by fixing screw
- weight including linear ball bearing
- load ratings according to the specification of the linear ball bearing
- 1) values of series LME..UUOP
- 2) angle of the housing; angle of the used linear ball bearing to be considered

Lineargehäuse-Einheit

Einzel geschlossen

Linear housing unit

Single closed

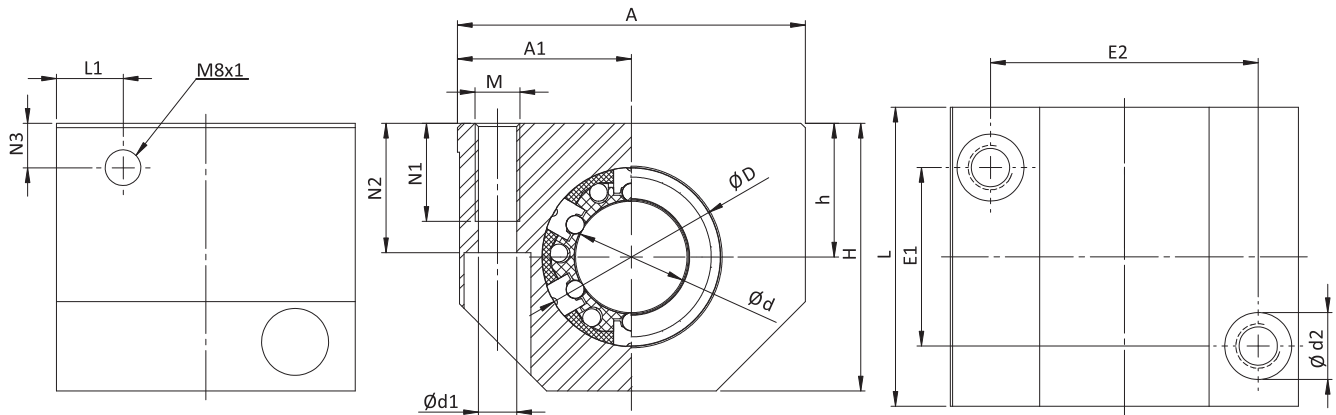

Abmessungen Dimensions (mm)

Gewicht Weight

Typ Type	Ød	ØD	H	h +0,01 -0,02	A	A1 ±0,02	L	N1	N2	N3	L1	E1 ±0,15	E2 ±0,15	Ød1	Ød2	M	Gew kg
EG12	12	22	35	18	43	21,5	39	13	16,5	10	10,5	23	32	4,2	8	M5	0,13
EG16	16	26	42	22	53	26,5	43	13	21	10	11,5	26	40	5,2	10	M6	0,20
EG20	20	32	50	25	60	30	54	18	24	10	13,5	32	45	6,8	11	M8	0,34
EG25	25	40	60	30	78	39	67	22	29	10	15	40	60	8,6	15	M10	0,65
EG30	30	47	70	35	87	43,5	79	22	34	11,5	16	45	68	8,6	15	M10	0,97
EG40	40	62	90	45	108	54	91	26	44	14	18	58	86	10,3	18	M12	1,80
EG50	50	75	105	50	132	66	115	34	49	12,5	22	50	108	14	20	M16	2,40

Bestellbeispiel / Ordering designation

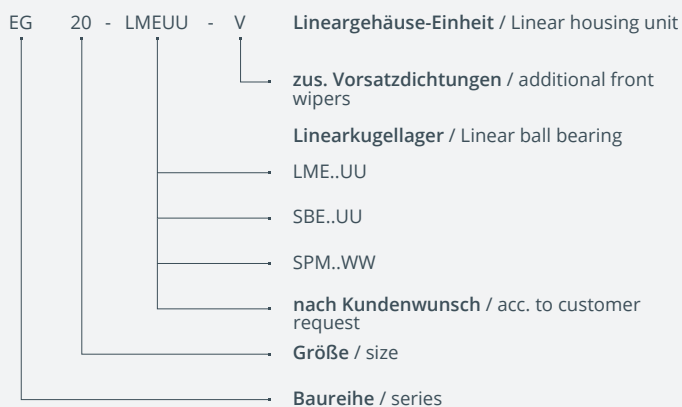

- Befestigungsschrauben DIN 912-8.8, Federring DIN 7980
- Befestigung des Lagers im Gehäuse mit Sicherungsringen nach DIN 472
- Gewichtsangabe mit Linearkugellager
- Tragzahlen nach Spezifikation des Linearkugellagers
- Schmierbohrung M8x1
- Produkt kann vom Bild / Zeichnungsdarstellung etwas abweichen
- fixing screws acc. DIN 912-8.8, spring washers acc. DIN 7980
- bearing fixing in the housing by circlips acc. DIN 472
- weight including linear ball bearing
- load ratings according to the specification of the linear ball bearing
- lubrication bore M8x1
- product may slightly vary from the photo / drawing shape



Lineargehäuse-Einheit

Einzel geschlossen, einstellbar

EGE

Linear housing unit

Single closed, adjustable

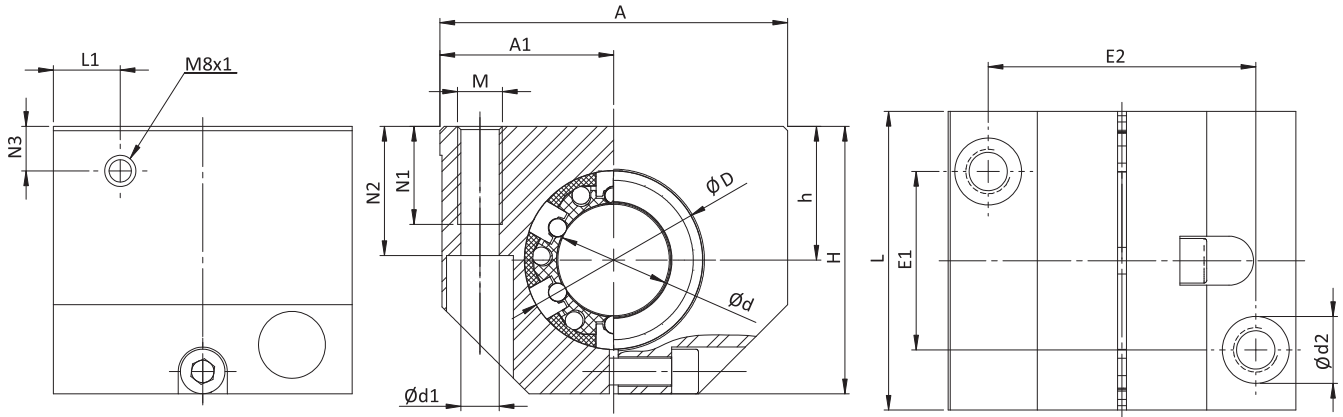

Abmessungen

Dimensions (mm)

Gewicht

Weight

Typ Type	Ø d	Ø D	H	h +0,01 -0,02	A	A1 ±0,02	L	N1	N2	N3	L1	E1 ±0,15	E2 ±0,15	Ød1	Ød2	M	Gew kg
EGE12	12	22	35	18	43	21,5	39	13	16,5	10	10,5	23	32	4,2	8	M5	0,13
EGE16	16	26	42	22	53	26,5	43	13	21	10	11,5	26	40	5,2	10	M6	0,20
EGE20	20	32	50	25	60	30	54	18	24	10	13,5	32	45	6,8	11	M8	0,34
EGE25	25	40	60	30	78	39	67	22	29	10	15	40	60	8,6	15	M10	0,65
EGE30	30	47	70	35	87	43,5	79	22	34	11,5	16	45	68	8,6	15	M10	0,97
EGE40	40	62	90	45	108	54	91	26	44	14	18	58	86	10,3	18	M12	1,80
EGE50	50	75	105	50	132	66	113	34	49	12,5	22	50	108	14	20	M16	2,40

Bestellbeispiel / Ordering designation

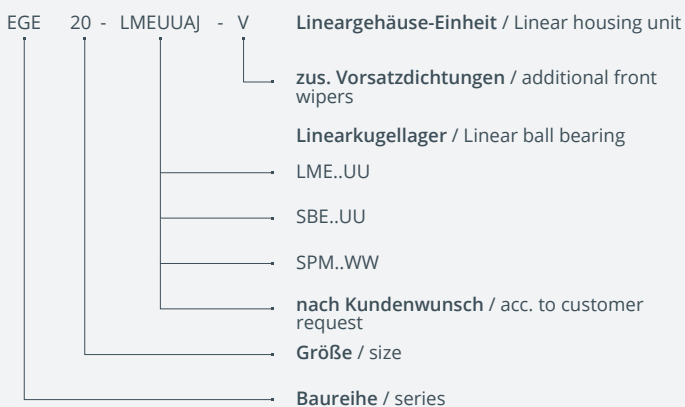

- Befestigungsschrauben DIN 912-8.8, Federring DIN 7980
- Befestigung des Lagers im Gehäuse mit Sicherungsringen nach DIN 472
- Gewichtsangabe mit Linearkugellager
- Tragzahlen nach Spezifikation des Linearkugellagers
- Schmierbohrung M8x1
- Produkt kann vom Bild / Zeichnungsdarstellung etwas abweichen
- fixing screws acc. DIN 912-8.8, spring washers acc. DIN 7980
- bearing fixing in the housing by circlips acc. DIN 472
- weight including linear ball bearing
- load ratings according to the specification of the linear ball bearing
- lubrication bore M8x1
- product may slightly vary from the photo / drawing shape

Lineargehäuse-Einheit

Einzel offen

Linear housing unit

Single open

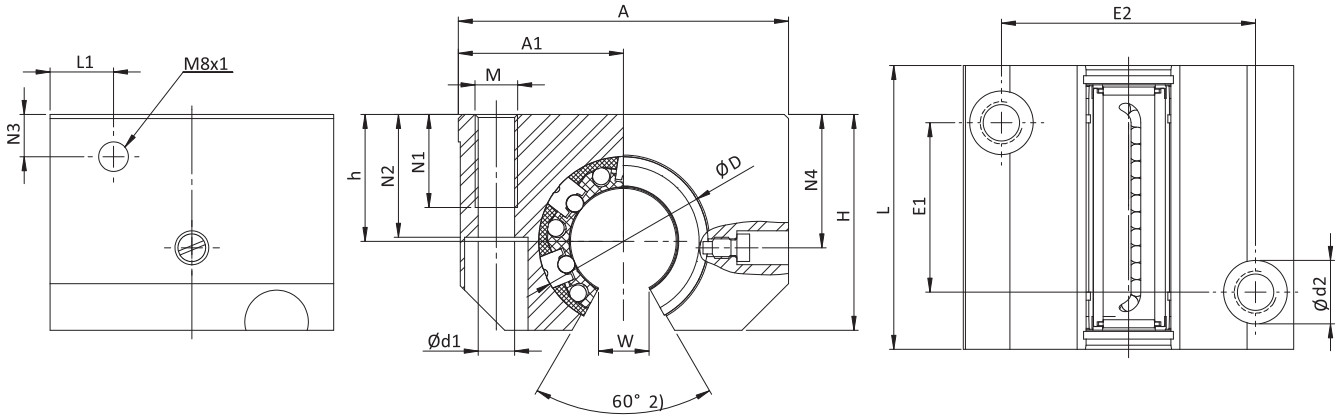

Abmessungen
Dimensions (mm)

Gewicht
Weight

Typ Type	Ød	ØD	H	h +0,01 -0,02	A	A1 ±0,02	L	E1 ±0,15	E2 ±0,15	N1	N2	N3	L1	N4	Ød1	Ød2	M	W 1)	Gew kg
EGO12	12	22	28	18	43	21,5	39	23	32	11	16,5	10	10,5	16,65	4,2	8	M5	7,5	0,11
EGO16	16	26	35	22	53	26,5	43	26	40	13	21	10	11,5	22	5,2	10	M6	10	0,17
EGO20	20	32	42	25	60	30	54	32	45	18	24	10	13,5	25	6,8	11	M8	10	0,30
EGO25	25	40	51	30	78	39	67	40	60	22	29	10	15	31,5	8,6	15	M10	12,5	0,57
EGO30	30	47	60	35	87	43,5	79	45	68	22	34	1,5	16	33	8,6	15	M10	12,5	0,86
EGO40	40	62	77	45	108	54	91	58	86	26	44	14	18	43,5	10,3	18	M12	16,8	1,60
EGO50	50	75	88	50	132	66	113	50	108	34	49	12,5	22	47,5	14	20	M16	21	2,20

Bestellbeispiel / Ordering designation

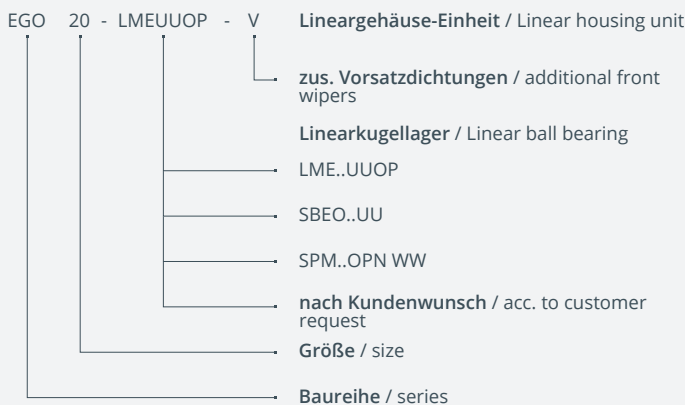

- Befestigungsschrauben DIN 912-8.8, Federring DIN 7980
- Befestigung des Lagers im Gehäuse mit Fixierschraube
- Gewichtsangabe mit Linearkugellager
- Tragzahlen nach Spezifikation des Linearkugellagers
- Schmierbohrung M8x1
- 1) Werte der Baureihe LME..UUOP
- 2) Winkel des Gehäuses; Winkel des verwendeten Linearkugellagers beachten
- Produkt kann vom Bild / Zeichnungsdarstellung etwas abweichen
- fixing screws acc. DIN 912-8.8, spring washers acc. DIN 7980
- bearing fixing in the housing by fixing screw
- weight including linear ball bearing
- load ratings according to the specification of the linear ball bearing
- lubrication bore M8x1
- 1) values of series LME..UUOP
- 2) angle of the housing; angle of the used linear ball bearing to be considered
- product may slightly vary from the photo / drawing shape

Lineargehäuse-Einheit

Einzel offen, einstellbar

EGOE

Linear housing unit

Single open, adjustable

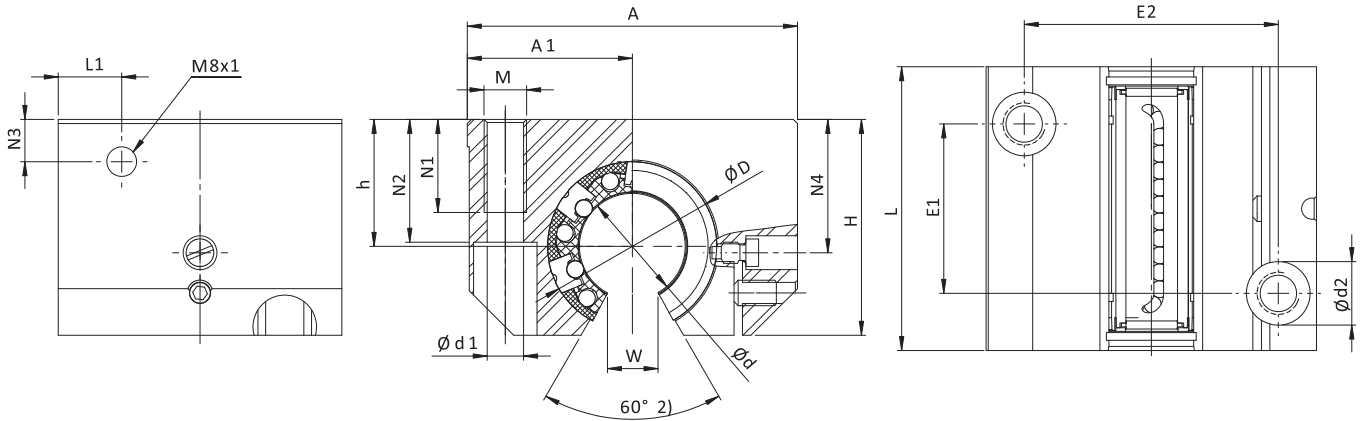

Abmessungen Dimensions (mm)

Gewicht Weight

Typ Type	Ød	ØD	H	h +0,01 -0,02	A	A1 ±0,02	L	E1 ±0,15	E2 ±0,15	N1	N2	N3	L1	N4	Ød1	Ød2	M	W 1)	Gew kg
EGOE12	12	22	28	18	43	21,5	39	23	32	11	16,5	10	10,5	16,65	4,2	8	M5	7,5	0,11
EGOE16	16	26	35	22	53	26,5	43	26	40	13	21	10	11,5	22	5,2	10	M6	10	0,17
EGOE20	20	32	42	25	60	30	54	32	45	18	24	10	13,5	25	6,8	11	M8	10	0,30
EGOE25	25	40	51	30	78	39	67	40	60	22	29	10	15	31,5	8,6	15	M10	12,5	0,57
EGOE30	30	47	60	35	87	43,5	79	45	68	22	34	1,5	16	33	8,6	15	M10	12,5	0,86
EGOE40	40	62	77	45	108	54	91	58	86	26	44	14	18	43,5	10,3	18	M12	16,8	1,60
EGOE50	50	75	88	50	132	66	113	50	108	34	49	12,5	22	47,5	14	20	M16	21	2,20

Bestellbeispiel / Ordering designation

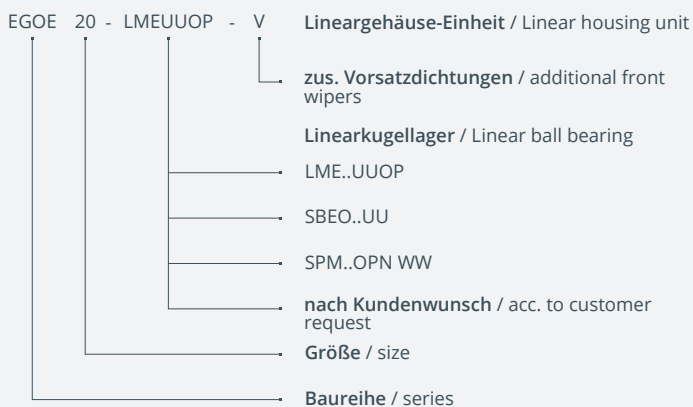

- Befestigungsschrauben DIN 912-8.8, Federring DIN 7980
- Befestigung des Lagers im Gehäuse mit Fixierschraube
- Gewichtsangabe mit Linearkugellager
- Tragzahlen nach Spezifikation des Linearkugellagers
- Schmierbohrung M8x1
- 1) Werte der Baureihe LME..UUOP
- 2) Winkel des Gehäuses; Winkel des verwendeten Linearkugellagers beachten
- Produkt kann vom Bild / Zeichnungsdarstellung etwas abweichen
- fixing screws acc. DIN 912-8.8, spring washers acc. DIN 7980
- bearing fixing in the housing by fixing screw
- weight including linear ball bearing
- load ratings according to the specification of the linear ball bearing
- lubrication bore M8x1
- 1) values of series LME..UUOP
- 2) angle of the housing; angle of the used linear ball bearing to be considered
- product may slightly vary from the photo / drawing shape

Lineargehäuse-Einheit

Seitlich offen

Linear housing unit

Side open

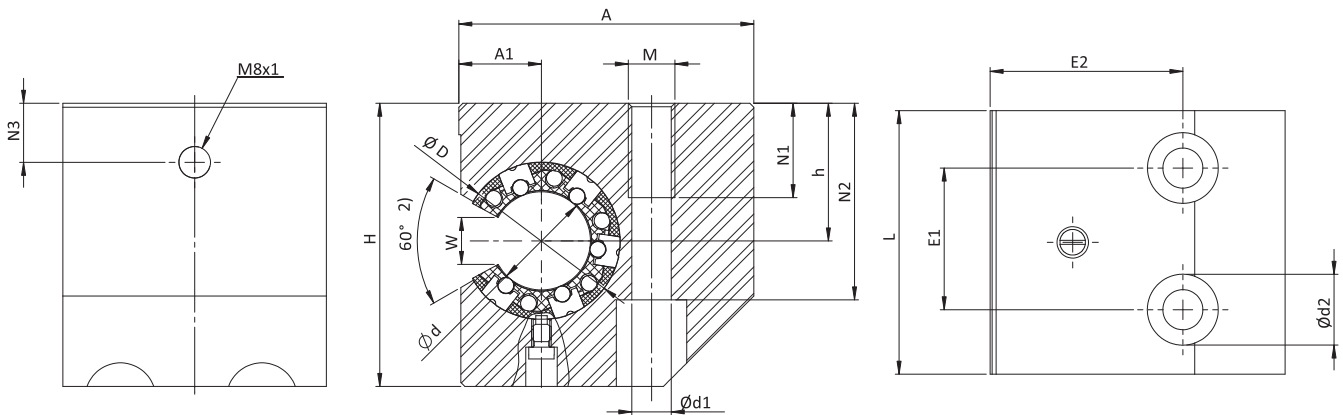
Abmessungen
Dimensions (mm)Gewicht
Weight

Typ Type	Ød	ØD	H	h ±0,015	A	A1 ±0,02	L	E1	E2	N1	N2	N3	Ød1	Ød2	M	W 1)	Gew kg
EGS20	20	32	60	30	60	17	54	30	39	22	42	30	8,6	15	M10	10	0,42
EGS25	25	40	72	35	75	21	67	36	49	26	50	35	10,3	18	M12	12,5	0,80
EGS30	30	47	82	40	86	25	79	42	59	34	55	40	13,5	20	M16	12,5	1,20
EGS40	40	62	100	45	110	32	91	48	75	43	67	45	17,5	26	M20	16,8	2,00

Bestellbeispiel / Ordering designation

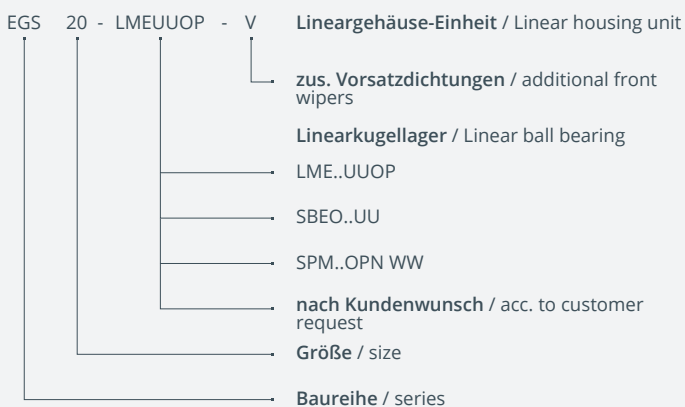

- Befestigungsschrauben DIN 912-8.8, Federring DIN 7980
- Befestigung des Lagers im Gehäuse mit Fixierschraube
- Gewichtsangabe mit Linearkugellager
- Tragzahlen nach Spezifikation des Linearkugellagers
- Schmierbohrung M8x1
- 1) Werte der Baureihe LME..UUOP
- 2) Winkel des Gehäuses; Winkel des verwendeten Linearkugellagers beachten
- fixing screws acc. DIN 912-8.8, spring washers acc. DIN 7980
- bearing fixing in the housing by fixing screw
- weight including linear ball bearing
- load ratings according to the specification of the linear ball bearing
- lubrication bore M8x1
- 1) values of series LME..UUOP
- 2) angle of the housing; angle of the used linear ball bearing to be considered



Lineargehäuse-Einheit

Seitlich offen, einstellbar

EGSE

Linear housing unit

Side open, adjustable

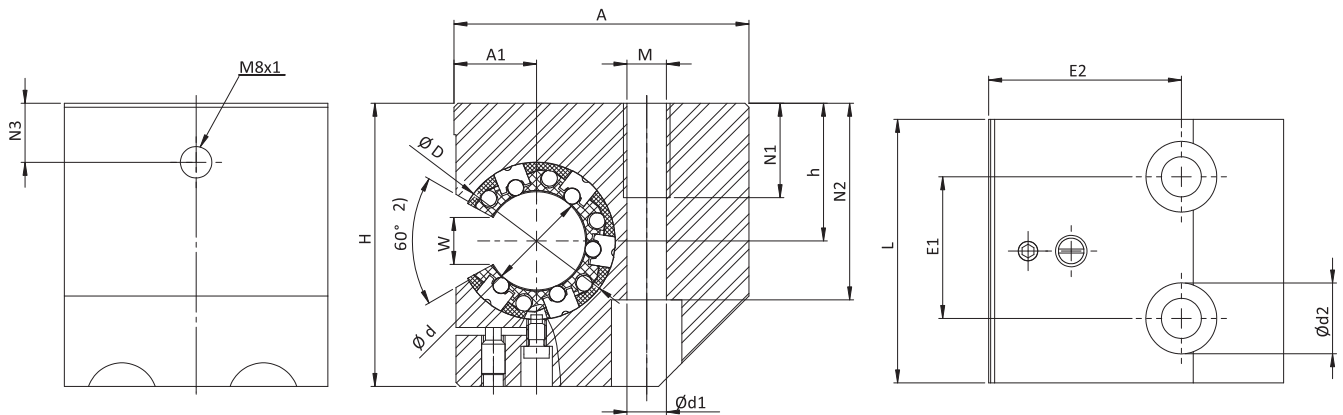

Abmessungen Dimensions (mm)

Gewicht Weight

Typ Type	Ød	ØD	H	h ±0,015	A	A1 ±0,02	L	E1	E2	N1	N2	N3	Ø d1	Ød2	M	W 1)	Gew kg
EGSE20	20	32	60	30	60	17	54	30	39	22	42	30	8,6	15	M10	10	0,42
EGSE25	25	40	72	35	75	21	67	36	49	26	50	35	10,3	18	M12	12,5	0,80
EGSE30	30	47	82	40	86	25	79	42	59	34	55	40	13,5	20	M16	12,5	1,20
EGSE40	40	62	100	45	110	32	91	48	75	43	67	45	17,5	26	M20	16,8	2,00

Bestellbeispiel / Ordering designation

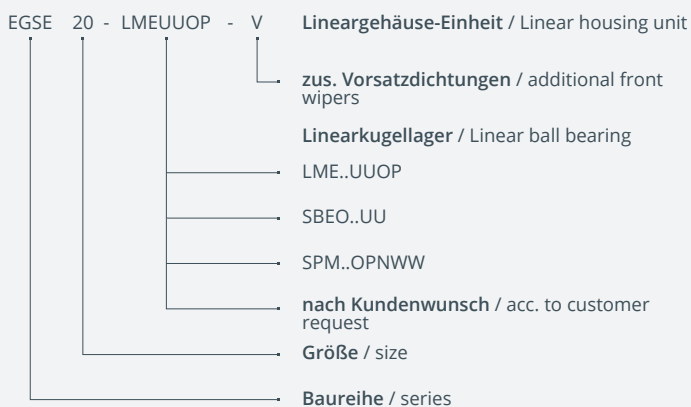

- Befestigungsschrauben DIN 912-8.8, Federring DIN 7980
- Befestigung des Lagers im Gehäuse mit Fixierschraube
- Gewichtsangabe mit Linearkugellager
- Tragzahlen nach Spezifikation des Linearkugellagers
- Schmierbohrung M8x1
- 1) Werte der Baureihe LME..UUOP
- 2) Winkel des Gehäuses; Winkel des verwendeten Linearkugellagers beachten
- fixing screws acc. DIN 912-8.8, spring washers acc. DIN 7980
- bearing fixing in the housing by fixing screw
- weight including linear ball bearing
- load ratings according to the specification of the linear ball bearing
- lubrication bore M8x1
- 1) values of series LME..UUOP
- 2) angle of the housing; angle of the used linear ball bearing to be considered

Lineargehäuse-Einheit

Tandem geschlossen

Linear housing unit

Tandem closed

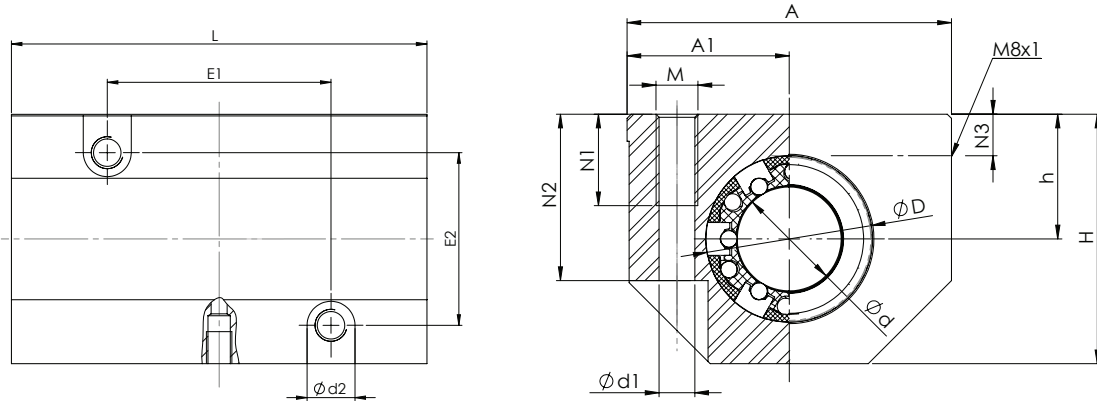

Abmessungen
Dimensions (mm)

Gewicht
Weight

Typ Type	Ød	ØD	H	h +0,01 -0,02	A	A1 ±0,02	L	E1 ±0,15	E2 ±0,15	N1	N2	N3	Ød1	Ød2	M	Gew kg
ETG08	8	16	28	13	35	17,5	62	35	25	11	19,5	8	4,2	8	M5	0,15
ETG12	12	22	35	18	43	21,5	76	40	30	13	25	10	5,2	10	M6	0,27
ETG16	16	26	42	22	53	26,5	84	45	36	13	30	12	5,2	10	M6	0,41
ETG20	20	32	50	25	60	30	104	55	45	18	34	13	6,8	11	M8	0,72
ETG25	25	40	60	30	78	39	130	70	54	22	40	15	8,6	15	M10	1,35
ETG30	30	47	70	35	87	43,5	152	85	62	26	48	16	10,3	18	M12	2,01
ETG40	40	62	90	45	108	54	176	100	80	34	60	20	14	20	M16	3,67
ETG50	50	75	105	50	132	66	224	125	100	34	49	20	14	20	M16	4,7

Bestellbeispiel / Ordering designation

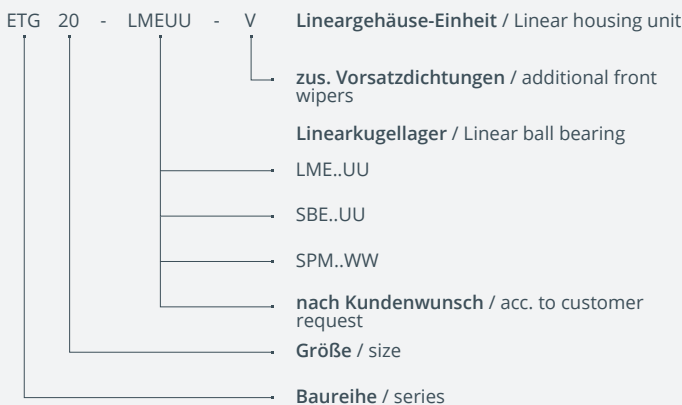

- Befestigungsschrauben DIN 912-8.8, Federring DIN 7980
- Befestigung des Lagers im Gehäuse mit Sicherungsringen nach DIN 472
- Gewichtsangabe mit Linearkugellager
- Tragzahlen nach Spezifikation des Linearkugellagers
- Schmierbohrung M8x1
- Produkt kann vom Bild / Zeichnungsdarstellung etwas abweichen
- fixing screws acc. DIN 912-8.8, spring washers acc. DIN 7980
- bearing fixing in the housing by circlips acc. DIN 472
- weight including linear ball bearing
- load ratings according to the specification of the linear ball bearing
- lubrication bore M8x1
- product may slightly vary from the photo / drawing shape



Lineargehäuse-Einheit

Tandem geschlossen, einstellbar

ETGE

Linear housing unit
Tandem closed, adjustable

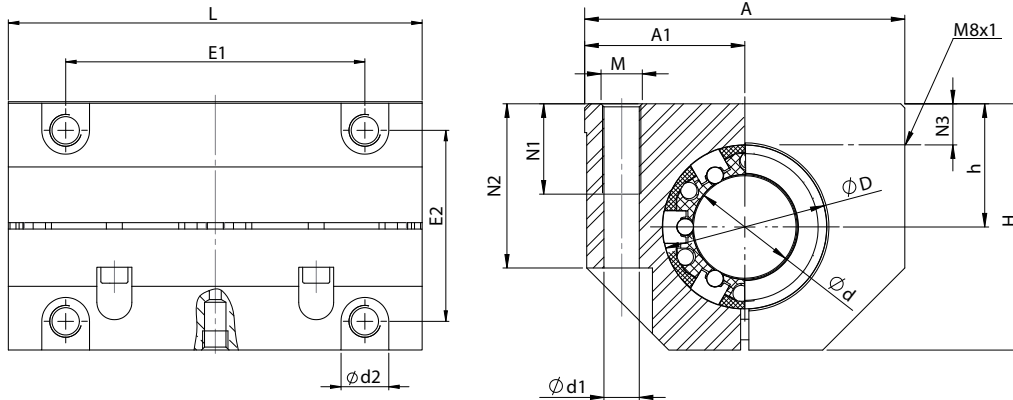

Abmessungen Dimensions (mm)

Gewicht Weight

Typ Type	Ø d	Ø D	H	h +0,01 -0,02	A	A1 ±0,02	L	E1 ±0,15	E2 ±0,15	N1	N2	N3	Ød1	Ød2	M	Gew kg
ETGE08	8	16	28	13	35	17,5	62	50	25	11	19,5	8	4,2	8	M5	0,15
ETGE12	12	22	35	18	43	21,5	76	56	32	11	25	10	4,2	8	M5	0,27
ETGE16	16	26	42	22	53	26,5	84	64	40	13	30	12	5,2	10	M6	0,41
ETGE20	20	32	50	25	60	30	104	76	45	18	34	13	6,8	11	M8	0,72
ETGE25	25	40	60	30	78	39	130	94	60	22	40	15	8,6	15	M10	1,35
ETGE30	30	47	70	35	87	43,5	152	106	68	22	48	16	8,6	15	M10	2,01
ETGE40	40	62	90	45	108	54	176	124	86	26	60	20	10,3	18	M12	3,67
ETGE50	50	79	105	50	132	66	224	160	108	34	49	20	14	20	M16	4,7

Bestellbeispiel / Ordering designation

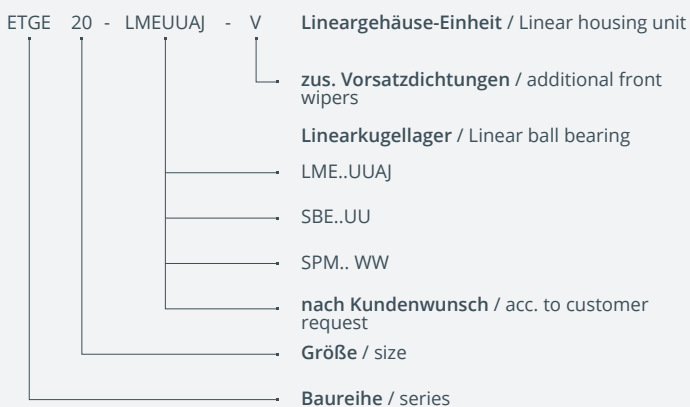

- Befestigungsschrauben DIN 912-8.8, Federring DIN 7980
- Befestigung des Lagers im Gehäuse mit Sicherungsringen nach DIN 472
- Gewichtsangabe mit Linearkugellager
- Tragzahlen nach Spezifikation des Linearkugellagers
- Schmierbohrung M8x1
- Produkt kann vom Bild / Zeichnungsdarstellung etwas abweichen
- fixing screws acc. DIN 912-8.8, spring washers acc. DIN 7980
- bearing fixing in the housing by circlips acc. DIN 472
- weight including linear ball bearing
- load ratings according to the specification of the linear ball bearing
- lubrication bore M8x1
- product may slightly vary from the photo / drawing shape

Lineargehäuse-Einheit

Tandem offen

Linear housing unit

Tandem open

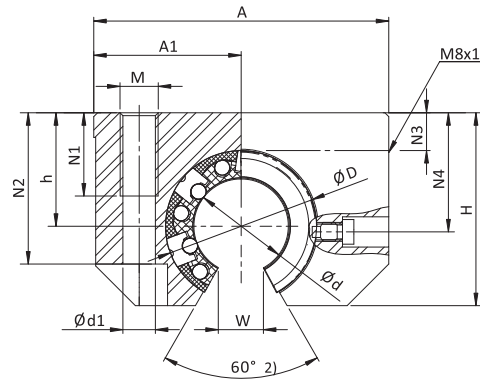
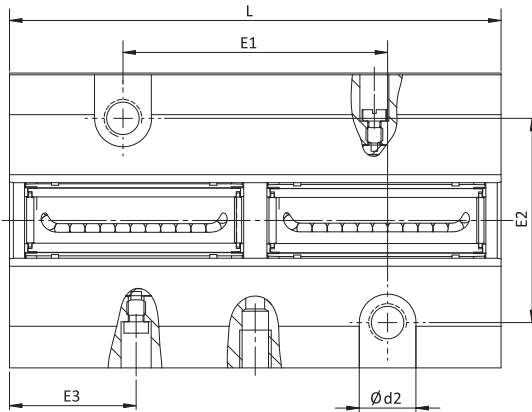

Abmessungen
Dimensions (mm)

Gewicht
Weight

Typ Type	Ød	ØD	H	h +0,01 -0,02	A	A1 ±0,02	L	E1 ±0,15	E2 ±0,15	E3 ±0,2	N1	N2	N3	N4	Ød1	Ød2	M	W 1)	Gew kg
ETGO12	12	22	30	18	43	21,5	76	40	30	19,5	13	25	10	16,65	5,2	10	M6	7,5	0,22
ETGO16	16	26	35	22	53	26,5	84	45	36	21,5	13	30	12	22	5,2	10	M6	10	0,34
ETGO20	20	32	42	25	60	30	104	55	45	27	18	34	13	25	6,8	11	M8	10	0,62
ETGO25	25	40	51	30	78	39	130	70	54	33,5	22	40	15	31,5	8,6	15	M10	12,5	1,17
ETGO30	30	47	60	35	87	43,5	152	85	62	39,5	26	48	16	33	10,3	18	M12	12,5	1,68
ETGO40	40	62	77	45	108	54	176	100	80	45	34	60	20	43,5	14	20	M16	16,8	3,15
ETGO50	50	75	88	50	132	66	224	125	100	56,5	34	49	20	47,5	14	20	M16	21	3,9

Bestellbeispiel / Ordering designation

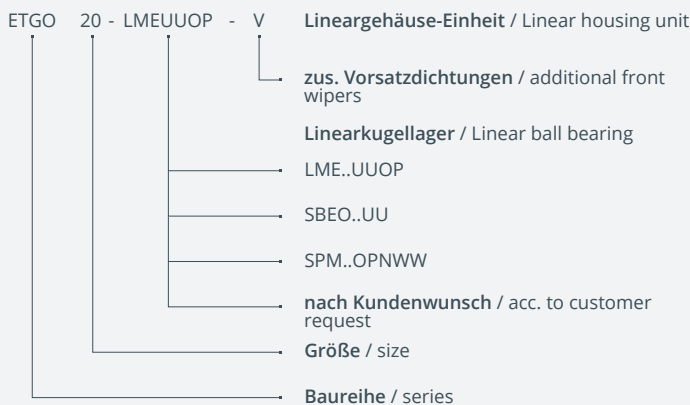

- Befestigungsschrauben DIN 912-8.8, Federring DIN 7980
- Befestigung des Lagers im Gehäuse mit Fixierschraube
- Gewichtsangabe mit Linearkugellager
- Tragzahlen nach Spezifikation des Linearkugellagers
- Schmierbohrung M8x1
- Produkt kann vom Bild / Zeichnungsdarstellung etwas abweichen
- 1) Werte der Baureihe LME..UUOP
- 2) Winkel des Gehäuses; Winkel des verwendeten Linearkugellagers beachten
- fixing screws acc. DIN 912-8.8, spring washers acc. DIN 7980
- bearing fixing in the housing by fixing screw
- weight including linear ball bearing
- load ratings according to the specification of the linear ball bearing
- lubrication bore M8x1
- product may slightly vary from the photo / drawing shape
- 1) values of series LME..UUOP
- 2) angle of the housing; angle of the used linear ball bearing to be considered



Lineargehäuse-Einheit

Tandem offen, einstellbar

ETGOE

Linear housing unit

Tandem open, adjustable

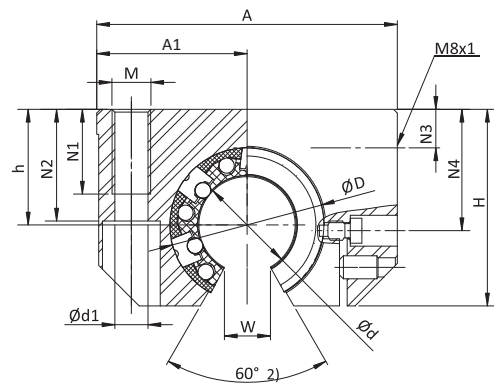
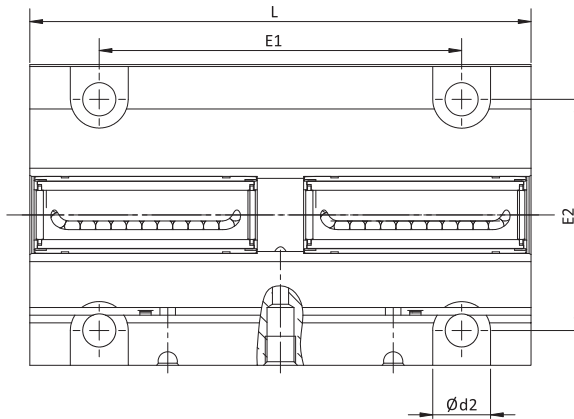

Abmessungen Dimensions (mm)

Gewicht Weight

Typ Type	Ød	ØD	H	h +0,01 -0,02	A	A1 ±0,02	L	E1 ±0,15	E2 ±0,15	N1	N2	N3	N4	Ød1	Ød2	M	W 1)	Gew kg
ETGOE12	12	22	28	18	43	21,5	76	56	32	11	25	10	16,65	4,2	8	M5	7,5	0,22
ETGOE16	16	26	35	22	53	26,5	84	64	40	13	30	12	22	5,2	10	M6	10	0,34
ETGOE20	20	32	42	25	60	30	104	76	45	18	34	13	25	6,8	11	M8	10	0,62
ETGOE25	25	40	51	30	78	39	130	94	60	22	40	15	31,5	8,6	15	M10	12,5	1,17
ETGOE30	30	47	60	35	87	43,5	152	106	68	22	48	16	33	8,6	15	M10	12,5	1,68
ETGOE40	40	62	77	45	108	54	176	124	86	26	60	20	43,5	10,3	18	M12	16,8	3,15
ETGOE50	50	75	88	50	132	66	224	160	108	34	49	20	47,5	14	20	M16	21	3,90

Bestellbeispiel / Ordering designation

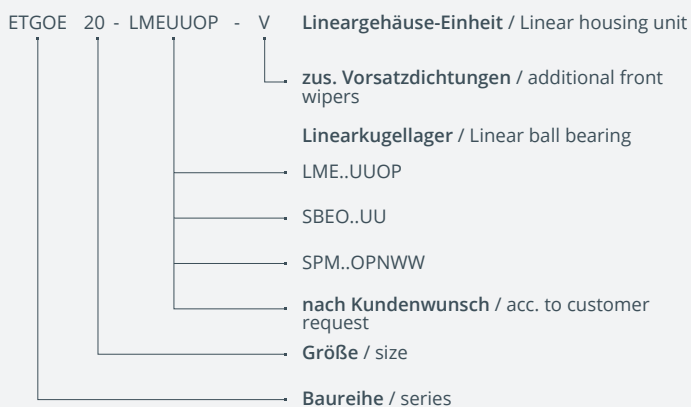

- Befestigungsschrauben DIN 912-8.8, Federring DIN 7980
- Befestigung des Lagers im Gehäuse mit Fixierschraube
- Gewichtsangabe mit Linearkugellager
- Tragzahlen nach Spezifikation des Linearkugellagers
- Schmierbohrung M8x1
- Produkt kann vom Bild / Zeichnungsdarstellung etwas abweichen
- 1) Werte der Baureihe LME..UUOP
- 2) Winkel des Gehäuses; Winkel des verwendeten Linearkugellagers beachten
- fixing screws acc. DIN 912-8.8, spring washers acc. DIN 7980
- bearing fixing in the housing by fixing screw
- weight including linear ball bearing
- load ratings according to the specification of the linear ball bearing
- lubrication bore M8x1
- product may slightly vary from the photo / drawing shape
- 1) values of series LME..UUOP
- 2) angle of the housing; angle of the used linear ball bearing to be considered

Lineargehäuse-Einheit
Tandem geschlossen
vier Befestigungsbohrungen



Linear housing unit
Tandem closed, Four fixing bores

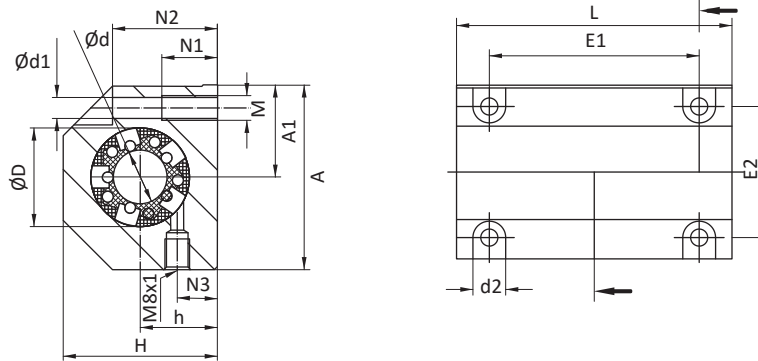

Abmessungen
Dimensions (mm)

Gewicht
weight

Typ Type	Ød	ØD	H	h +0,01 -0,02	A	A1 ±0,02	L	E1 ±0,15	E2 ±0,15	N1	N2	Ød1	d2	M	Gew kg
ITGI08-..	8	16	28	13	35	17,5	62	50	25	11	14	4,2	8	M5	0,15
ITGI12-..	12	22	35	18	43	21,5	76	56	32	11	16,5	4,2	8	M5	0,27
ITGI16-..	16	26	42	22	53	26,5	84	64	40	13	21	5,2	10	M6	0,41
ITGI20-..	20	32	50	25	60	30	104	76	45	18	24	6,8	11	M8	0,72
ITGI25-..	25	40	60	30	78	39	130	94	60	22	29	8,6	15	M10	1,35
ITGI30-..	30	47	70	35	87	43,5	152	106	68	22	34	8,6	15	M10	2,01
ITGI40-..	40	62	90	45	108	54	176	124	86	26	44	10,3	18	M12	3,67

Bestellbeispiel / Ordering designation

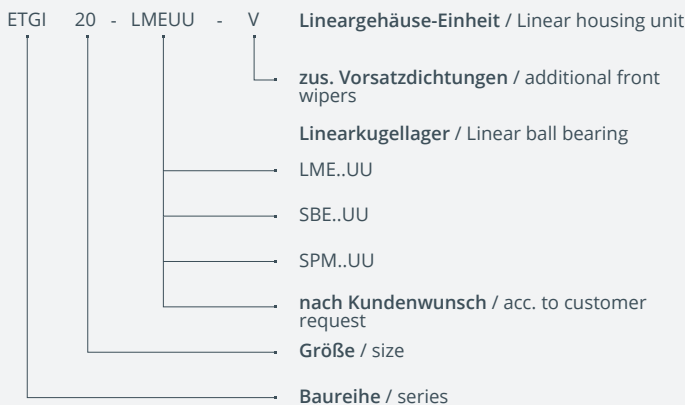

- Befestigungsschrauben DIN 912-8.8, Federring DIN 7980
- Befestigung des Lagers im Gehäuse mit Fixierschraube
- Gewichtsangabe mit Linearkugellager
- Tragzahlen nach Spezifikation des Linearkugellagers
- Schmierbohrung M8x1
- Produkt kann vom Bild / Zeichnungsdarstellung etwas abweichen
- fixing screws acc. DIN 912-8.8, spring washers acc. DIN 7980
- bearing fixing in the housing by fixing screw
- weight including linear ball bearing
- load ratings according to the specification of the linear
- lubrication bore M8x1
- ball bearing
- product may slightly vary from the photo / drawing shape



Lineargehäuse-Einheit

Tandem offen
vier Befestigungsbohrungen



Linear housing unit

Tandem open, Four fixing bores

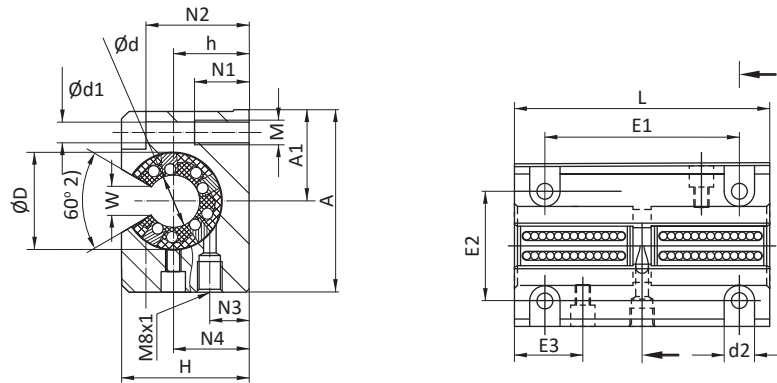

Abmessungen
Dimensions (mm)

Gewicht
weight

Typ Type	Ød	ØD	H	h +0,01 -0,02	A	A1 ±0,02	L	E1 ±0,15	E2 ±0,15	E3 ±0,2	N1	N2	N4	Ød1	d2	M	W 1)	Gew kg
ITGOI12-..	12	22	30	18	43	21,5	76	56	32	19,5	11	16,5	16,7	4,2	8	M5	7,5	0,22
ITGOI16-..	16	26	35	22	53	26,5	84	64	40	21,5	13	21	22	5,2	10	M6	10	0,34
ITGOI20-..	20	32	42	25	60	30	104	76	45	27	18	24	25	6,8	11	M8	10	0,62
ITGOI25-..	25	40	51	30	78	39	130	94	60	33,5	22	29	31,5	8,6	15	M10	12,5	1,17
ITGOI30-..	30	47	60	35	87	43,5	152	106	68	39,5	22	34	33	8,6	15	M10	12,5	1,68
ITGOI40-..	40	62	77	45	108	54	176	124	86	45,5	26	44	43,5	10,3	18	M12	16,8	3,15

Bestellbeispiel / Ordering designation

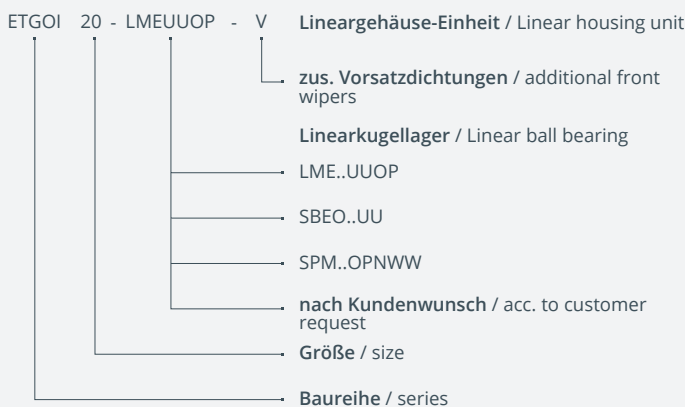

- Befestigungsschrauben DIN 912-8.8, Federring DIN 7980
- Befestigung des Lagers im Gehäuse mit Fixierschraube
- Gewichtsangabe mit Linearkugellager
- Tragzahlen nach Spezifikation des Linearkugellagers
- Schmierbohrung M8x1
- Produkt kann vom Bild / Zeichnungsdarstellung etwas abweichen
- 1) Werte der Baureihe LME..UUOP
- 2) Winkel des Gehäuses; Winkel des verwendeten Linearkugellagers beachten
- fixing screws acc. DIN 912-8.8, spring washers acc. DIN 7980
- bearing fixing in the housing by fixing screw
- weight including linear ball bearing
- load ratings according to the specification of the linear ball bearing
- lubrication bore M8x1
- product may slightly vary from the photo / drawing shape
- 1) values of series LME..UUOP
- 2) angle of the housing; angle of the used linear ball bearing to be considered

Lineargehäuse-Einheit

Quattro geschlossen

Linear housing unit

Quattro closed

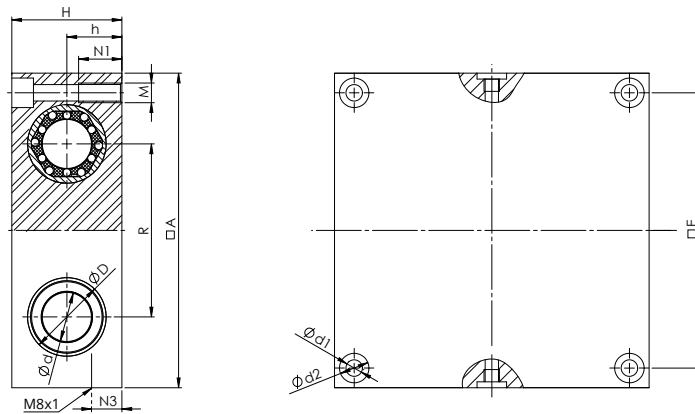
Abmessungen
Dimensions (mm)Gewicht
Weight

Typ Type	Ød	ØD	H	h ±0,02	A	R ±0,02	E	N1	N3	Ød1	Ød2	M	Gew kg
EQSG08	8	16	23	11.5	65	32	55	11	19,5	4,2	8	M5	0,18
EQSG12	12	22	32	16	85	42	73	13	27	5,2	10	M6	0,45
EQSG16	16	26	36	18	100	54	88	13	31	5,2	10	M6	0,63
EQSG20	20	32	46	23	130	72	115	18	39	6,8	11	M8	1,45
EQSG25	25	40	56	28	160	88	140	22	48	8,6	15	M10	2,65
EQSG30	30	47	64	32	180	96	158	26	55	10,3	18	M12	3,7
EQSG40	40	62	80	40	230	122	202	34	71	14	20	M16	7,3
EQSG50	50	75	96	48	280	152	250	34	86	14	20	M16	13

Bestellbeispiel / Ordering designation

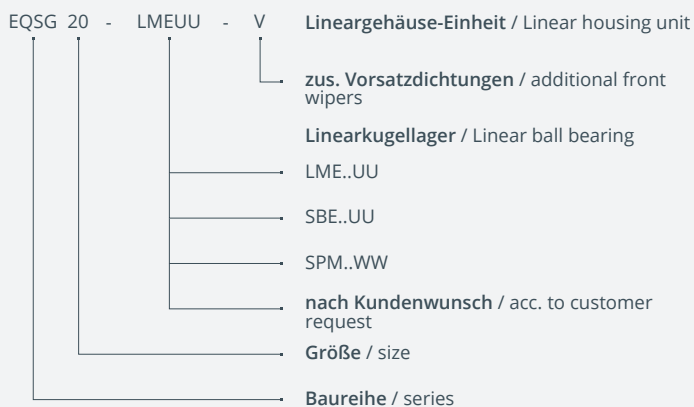

- Befestigungsschrauben DIN 912-8.8, Federring DIN 7980
- Befestigung des Lagers im Gehäuse mit Sicherungsringen nach DIN 472
- Gewichtsangabe mit Linearkugellager
- Tragzahlen nach Spezifikation des Linearkugellagers
- Schmierbohrung M8x1
- Produkt kann vom Bild / Zeichnungsdarstellung etwas abweichen
- fixing screws acc. DIN 912-8.8, spring washers acc. DIN 7980
- bearing fixing in the housing by circlips acc. DIN 472
- weight including linear ball bearing
- load ratings according to the specification of the linear ball bearing
- lubrication bore M8x1
- product may slightly vary from the photo / drawing shape



Lineargehäuse-Einheit

Quattro offen

EQSO

Linear housing unit

Quattro open

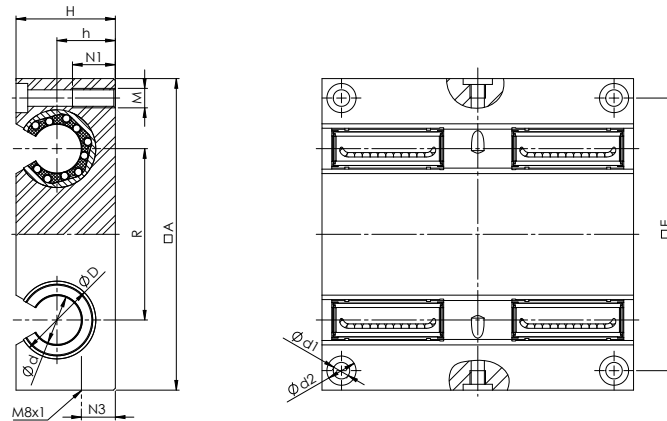

Abmessungen Dimensions (mm)

Gewicht Weight

Typ Type	Ød	ØD	H	h ±0,02	A	R ±0,02	E	N1	N3	Ød1	Ød2	M	Gew kg
EQSO12	12	22	30	18	85	42	73	13	27	5,2	10	M6	0,35
EQSO16	16	26	35	22	100	54	88	13	31	5,2	10	M6	0,6
EQSO20	20	32	42	25	130	72	115	18	39	6,8	11	M8	1,25
EQSO25	25	40	51	30	160	88	140	22	48	8,6	15	M10	2,2
EQSO30	30	47	60	35	180	96	158	26	55	10,3	18	M12	3,2
EQSO40	40	62	77	45	230	122	202	34	71	14	20	M16	6,75
EQSO50	50	75	93	55	280	152	250	34	86	14	20	M16	12,4

Bestellbeispiel / Ordering designation

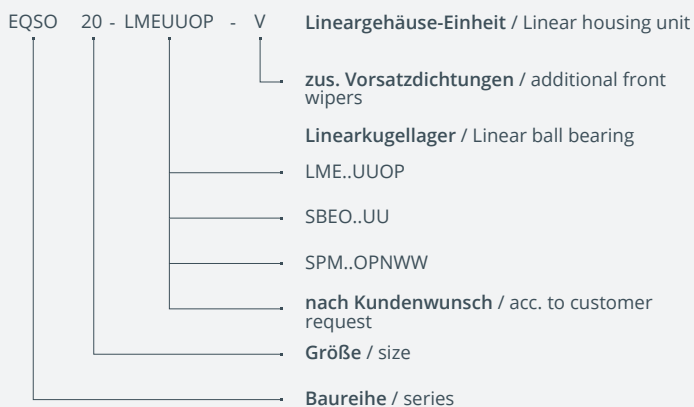

- Befestigungsschrauben DIN 912-8.8, Federring DIN 7980
- Befestigung des Lagers im Gehäuse mit Fixierschraube
- Gewichtsangabe mit Linearkugellager
- Tragzahlen nach Spezifikation des Linearkugellagers
- Schmierbohrung M8x1
- Produkt kann vom Bild / Zeichnungsdarstellung etwas abweichen
- 1) Werte der Baureihe LME..UUOP
- 2) Winkel des Gehäuses; Winkel des verwendeten Linearkugellagers beachten
- fixing screws acc. DIN 912-8.8, spring washers acc. DIN 7980
- bearing fixing in the housing by fixing screw
- weight including linear ball bearing
- load ratings according to the specification of the linear ball bearing
- lubrication bore M8x1
- product may slightly vary from the photo / drawing shape
- 1) values of series LME..UUOP
- 2) angle of the housing; angle of the used linear ball bearing to be considered

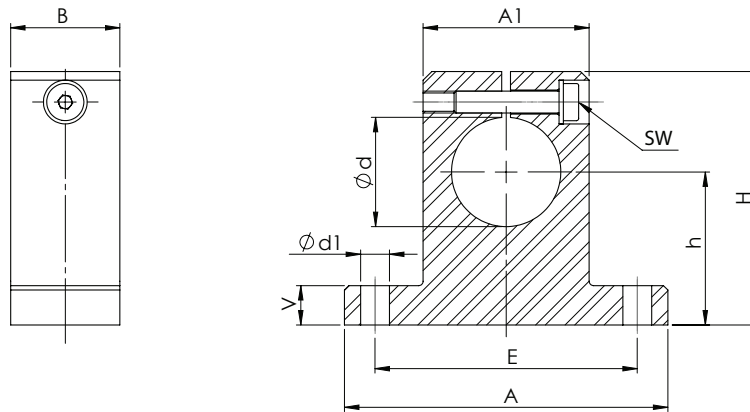

Abmessungen
Dimensions (mm)

Gewicht
Weight

Typ Type	Ød H8	H	h ±0,02	A	A1	B	E ±0,15	Ød1	V	SW	Gew kg
EGWA08	8	27	15	32	16	10	25	4,5	5,0	2,5	0,01
EGWA12	12	35	20	42	20	12	32	5,5	5,5	3	0,02
EGWA16	16	42	25	50	26	16	40	5,5	6,5	3	0,03
EGWA20	20	50	30	60	32	20	45	5,5	8,0	3	0,07
EGWA25	25	58	35	74	38	25	60	6,6	9,0	4	0,14
EGWA30	30	68	40	84	45	28	68	9,0	10,0	5	0,20
EGWA40	40	86	50	108	56	32	86	11,0	12,0	6	0,48
EGWA50	50	100	60	130	80	40	108	11,0	14,0	6	1,90
EGWA60	60	124	75	160	100	48	132	13,5	15,0	8	3,60



Wellenbock
Kompaktausführung

EGWH

Shaft support block
Compact series

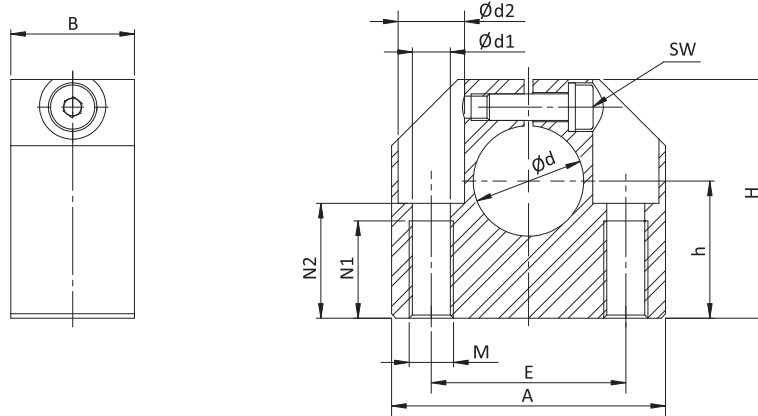

Abmessungen
Dimensions (mm)

Gewicht
Weight

Typ Type	ϕd	A	B	H	h $\pm 0,02$	E $\pm 0,12$	$\phi d1$	$\phi d2$	M	N1	N2	SW	Gew kg
EGWH06	6	32	16	27	15	22	4,2	8	M5	11	13	2,5	0,03
EGWH08	8	32	16	27	16	22	4,2	8	M5	11	13	2,5	0,03
EGWH10	10	40	18	33	18	27	5,2	10	M6	13	16	3	0,05
EGWH12	12	40	18	33	19	27	5,2	10	M6	13	16	3	0,05
EGWH14	14	45	20	38	20	32	5,2	10	M6	13	18	3	0,07
EGWH16	16	45	20	38	22	32	5,2	10	M6	13	18	3	0,07
EGWH20	20	53	24	45	25	39	6,8	11	M8	18	22	4	0,12
EGWH25	25	62	28	54	31	44	8,6	15	M10	22	26	5	0,17
EGWH30	30	67	30	60	34	49	8,6	15	M10	22	29	5	0,22
EGWH40	40	87	40	76	42	66	10,3	18	M12	26	38	6	0,48
EGWH50	50	103	50	92	50	80	14,25	20	M16	34	46	8	0,82

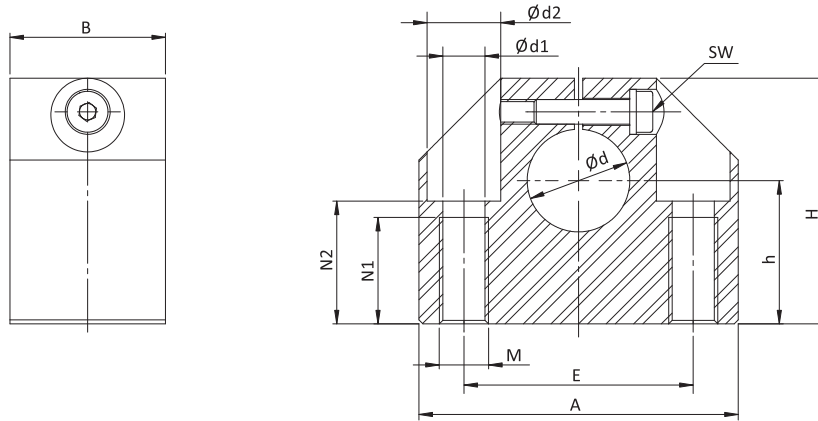
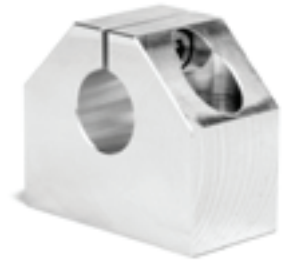
Abmessungen
 Dimensions (mm)

Gewicht
 Weight

Typ Type	$\varnothing d$	A	B	H	h $\pm 0,02$	E $\pm 0,12$	$\varnothing d1$	$\varnothing d2$	M	N1	N2	SW	Gew kg
EGWN08	8	32	18	28	15	22	3,3	6	M4	9	13,0	2,5	0,04
EGWN12	12	43	20	35	20	30	5,2	10	M6	13	16,5	3	0,10
EGWN16	16	53	24	42	25	38	6,8	11	M8	18	21,0	4	0,15
EGWN20	20	60	30	50	30	42	8,6	15	M10	22	25,0	5	0,23
EGWN25	25	78	38	60	35	56	10,3	18	M12	26	30,0	6	0,41
EGWN30	30	87	40	70	40	64	10,3	18	M12	26	34,0	6	0,53
EGWN40	40	108	48	90	50	82	14,25	20	M16	34	44,0	8	0,99
EGWN50	50	132	58	105	60	100	17,5	26	M20	43	49,0	10	1,25



Flanschwellenbock

EFWB

Shaft support block with flange

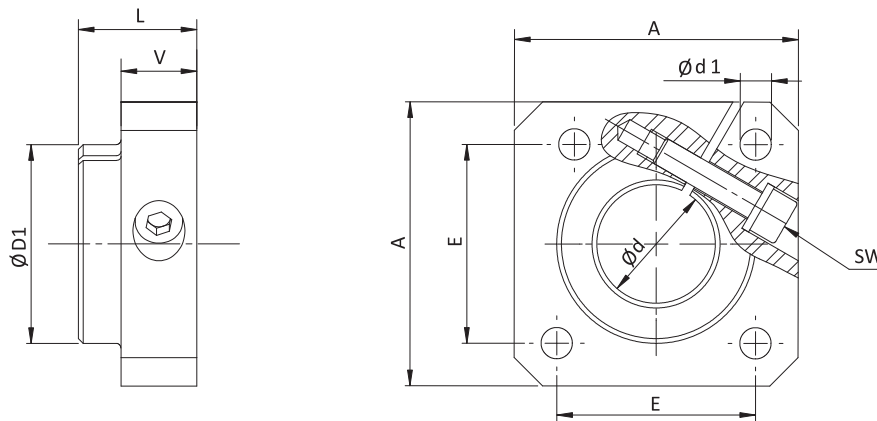

Abmessungen Dimensions (mm)

Gewicht Weight

Typ Type	Ød	A	L	ØD1	E	V	Ød1	SW	Gew kg
EFWB12	12	40	20	23,5	30	12	5,5	3	0,06
EFWB16	16	50	20	27,5	35	12	5,5	3	0,08
EFWB20	20	50	23	33,5	38	14	6,6	4	0,10
EFWB25	25	60	25	42,0	42	16	6,6	5	0,15
EFWB30	30	70	30	49,5	54	19	9	6	0,30
EFWB40	40	100	40	65,0	68	26	11	8	0,70
EFWB50	50	100	50	75,0	75	36	11	8	1,20

Wellenbock

Tandem, Kompaktausführung

Shaft support block

Tandem, compact series

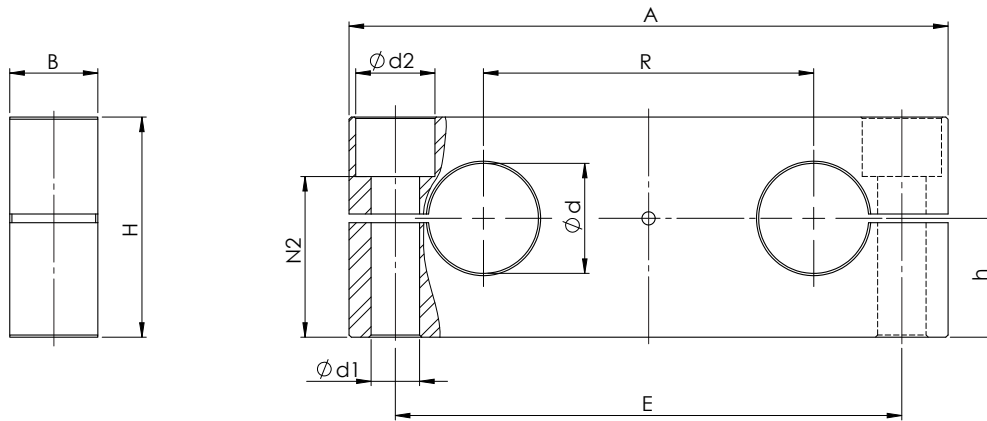

Abmessungen

Dimensions (mm)

Gewicht

Weight

Typ Type	Ød	A	B	H	h ±0,015	R ±0,02	E	Ød1	Ød2	N2	Gew kg
ETAC12	12	80	15	30	17	40	64	6,6	11	21,5	0,1
ETAC16	16	96	15	35	19,5	52	80	6,6	11	26,5	0,15
ETAC20	20	115	18	40	22	63	97	9	15	28	0,2
ETAC25	25	136	20	50	27	75	115	11	18	36,5	0,25
ETAC30	30	146	20	56	31	80	125	11	18	42,5	0,35
ETAC40	40	184	25	70	38	97	160	13,5	20	54	0,65
ETAC50	50	210	30	80	43	107	180	17,5	26	59	0,85



Wellenbock

Tandem, fest

ETA

Shaft support block

Tandem, fixed

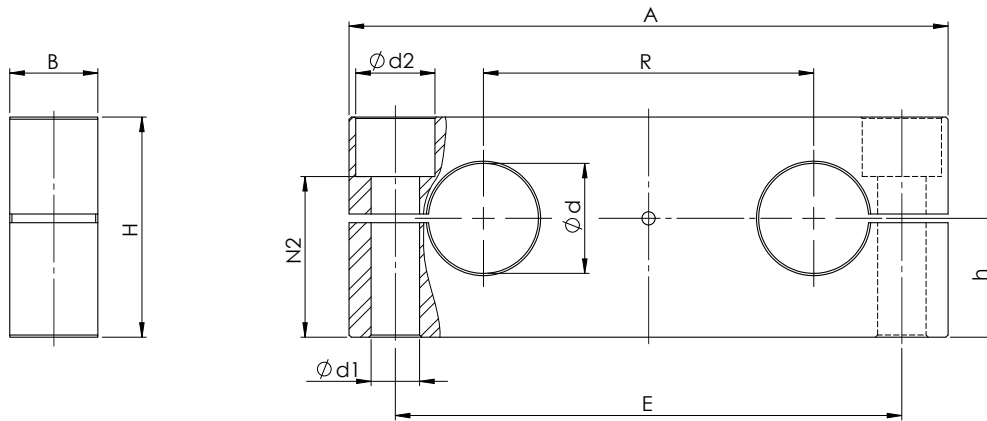

Abmessungen
Dimensions (mm)

Gewicht
Weight

Typ Type	Ød	A	B	H	h ±0,015	R ±0,02	E	Ød1	Ød2	N2	Gew kg
ETA08	8	65	12	22	12,5	32	52	5,5	10	17,6	0,04
ETA12	12	85	14	32	18	42	70	6,6	11	23,5	0,09
ETA16	16	100	18	36	20	54	82	9	15	26,5	0,14
ETA20	20	130	20	46	25	72	108	11	18	32,5	0,26
ETA25	25	160	25	56	30	88	132	13,5	20	40	0,47
ETA30	30	180	25	64	35	96	150	13,5	20	48	0,63
ETA40	40	230	30	80	44	122	190	17,5	26	59	1,1
ETA50	50	280	30	96	52	152	240	17,5	26	75	1,65

ETB

Wellenbock
Tandem, beweglich

Shaft support block
Tandem, movable

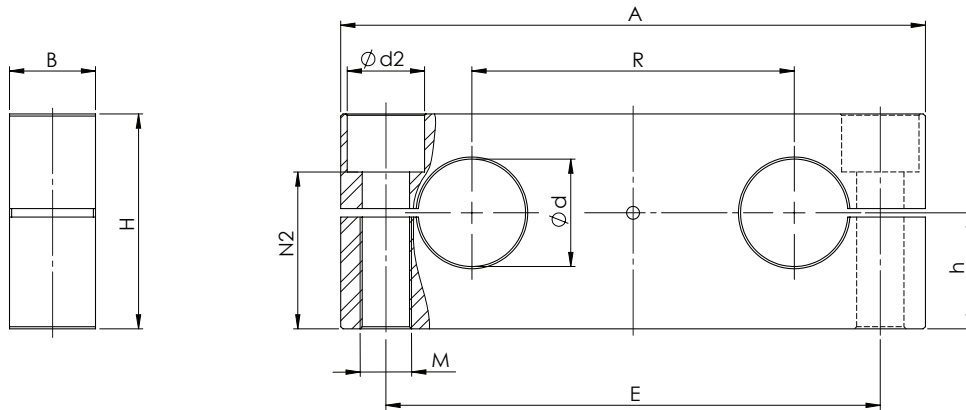

Abmessungen
Dimensions (mm)

Gewicht
Weight

Typ Type	Ød	A	B	H	h ±0,015	R ±0,02	E	M	Ød2	N2	Gew kg
ETB08	8	65	12	22	11	32	52	M5	10	16,6	0,04
ETB12	12	85	14	28	14	42	70	M6	11	21,6	0,07
ETB16	16	100	18	32	16	54	82	M8	15	23,4	0,12
ETB20	20	130	20	42	21	72	108	M10	18	31,4	0,22
ETB25	25	160	25	52	26	88	132	M12	20	39,4	0,43
ETB30	30	180	25	58	29	96	150	M12	20	45,4	0,57
ETB40	40	230	30	72	36	122	190	M16	26	55,4	0,98
ETB50	50	280	30	88	44	152	240	M16	26	71,4	1,5



Tragschienen

Niedrige Ausführung

ETSU

Shaft support rail units

Thin series

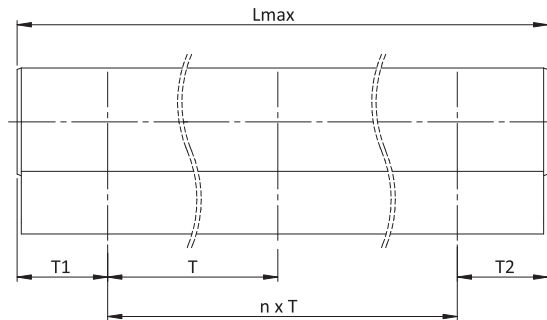
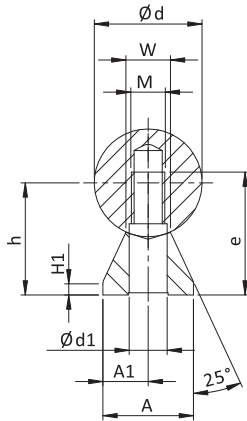

Abmessungen Dimensions (mm)

Gewicht Weight

Typ Type	Ød	h ±0,15	H1	A	A1	W	M	Ød1	e	T	Gew kg/m
ETSU12	12	14,5	3	11	5,5	5,4	M4	4,5	15,5	75	0,21
ETSU16	16	18	3	14	7,0	7,0	M5	5,5	16,0	75	0,31
ETSU20	20	22	3	17	8,5	8,1	M6	6,6	20,0	75	0,45
ETSU25	25	26	3	21	10,5	10,3	M8	9,0	25,0	75	0,59
ETSU30	30	30	3	23	11,5	11,0	M10	11,0	30,0	100	0,74
ETSU40	40	39	4	30	15,0	15,0	M12	13,5	38,0	100	1,26

Bestellbeispiel / Ordering designation

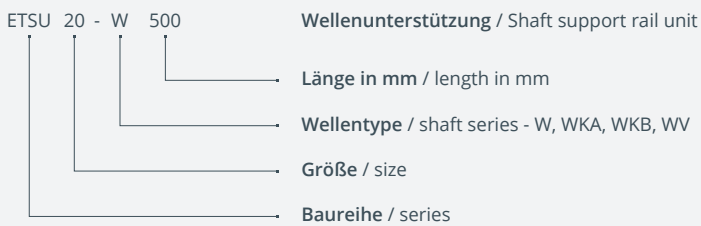

- Gewicht ohne Welle
- der Wellenunterstützung kann je nach Tragschienenlänge aus mehreren Teilstücken zusammengesetzt sein
- T1/T2min = 20 mm
- Maximale einteilige Länge Wellenunterstützung: 4000 mm +7
- weight without shaft
- depending on the length of the support shaft rail unit, the rail may be composed of several individual sections
- Max. single length of support: 4000 mm +7

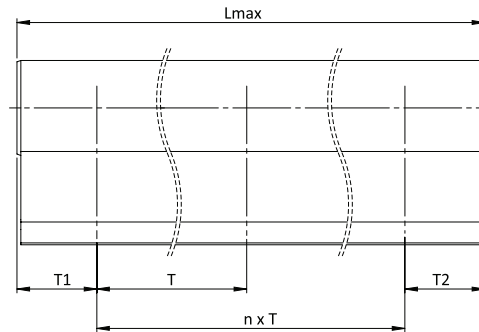
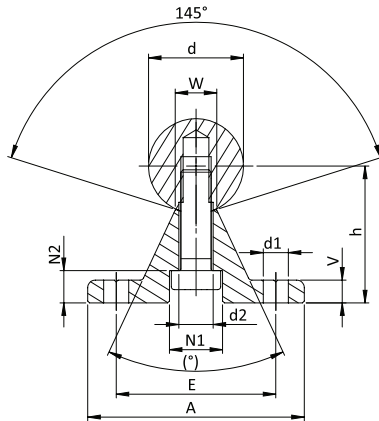

Abmessungen
Dimensions (mm)

Gewicht
Weight

Typ Type	Ød	A	h ±0,15	V	N1	N2	Ød1	Ød2	W	(O)	E	T _A	T _B	Gew kg/m
ETSN12	12	40	22	5	8,0	5,0	4,5	4,5	5,8	50	29	75	120	0,75
ETSN16	16	45	26	5	9,5	6,0	5,5	5,5	7,0	50	33	100	150	0,92
ETSN20	20	52	32	6	11,0	6,5	6,6	6,6	8,3	50	37	100	150	1,33
ETSN25	25	57	36	6	14,0	8,5	6,6	9,0	10,8	50	42	120	200	1,52
ETSN30	30	69	42	7	17,0	10,5	9,0	11,0	11,0	50	51	150	200	1,92
ETSN40	40	73	50	8	17,0	10,5	9,0	11,0	15,0	50	55	200	300	2,64
ETSN50	50	84	60	9	19,0	12,5	11,0	13,0	19,0	46	63	200	300	3,55

Bestellbeispiel / Ordering designation

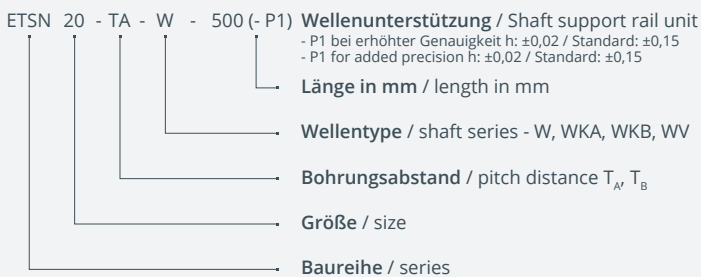

- Gewicht ohne Welle
- die Wellenunterstützung ist je nach Tragschienenlänge aus mehreren Teilstücken zusammengesetzt
- T1/T2min = 20 mm
- Maximale einteilige Länge Wellenunterstützung:
 600 mm -0,5 / -1,5 bei P1 (±0,02)
 4250 mm +7 bei Standard (±0,15)
- weight without shaft
- depending on the length of the shaft support rail unit, the rail is composed of several individual sections
- Max. single length of support:
 600 mm -0,5 / -1,5 for P1 (±0,02)
 4250 mm +7 for standard (±0,15)

Shaft support rail units
Flat series

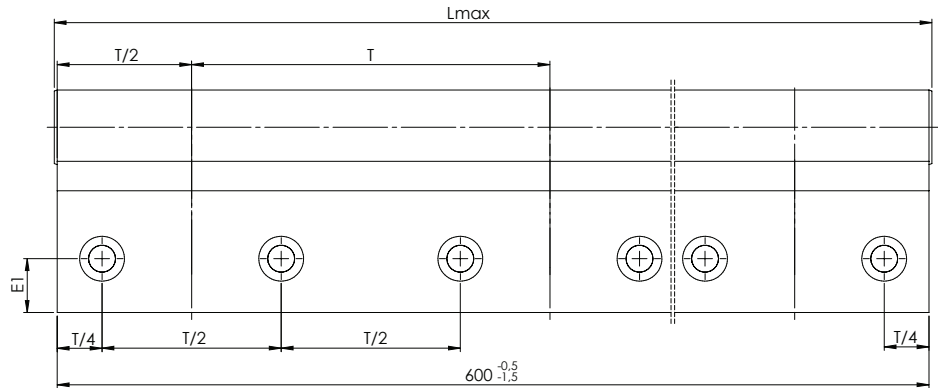
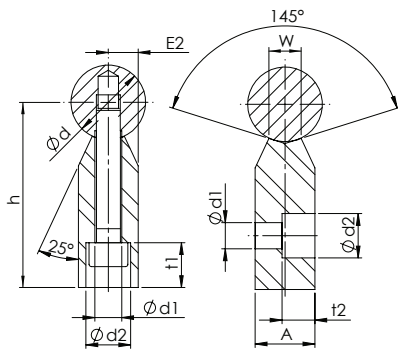

Abmessungen
Dimensions (mm)

Gewicht
Weight

Typ Type	Ød	A	h	E1	E2	E3	W	Ød1	Ød2	t1	t2	T	Gew kg
ETSS20	20	15	52	8	7,5	22	8,3	6,6	11	8,5	8,5	100	0,85
ETSS25	25	20	62	10	10	26	10	9	15	15	11	120	1,35
ETSS30	30	25	72	12	12,5	30	11	11	18	15,3	13,5	150	1,85
ETSS40	40	30	88	12	15	38	15	14	20	17,5	16	200	2,65
ETSS50	50	35	105	15	17,5	45	19	15,5	24	21,5	18,5	200	3,55

Bestellbeispiel / Ordering designation

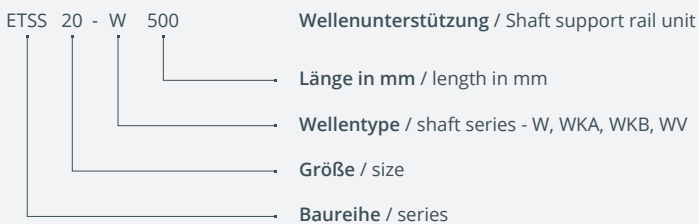

- Gewicht ohne Welle bezogen auf 600 mm
- der Wellenunterstützung kann je nach Tragschienenlänge aus mehreren Teilstücken zusammengesetzt sein
- T1/T2min = 20 mm
- weight without shaft in relation to 600 mm
- depending on the length of the support shaft rail unit, the rail may be composed of several individual sections

Nadelrollen-Flachkäfige

Needle roller flat cages

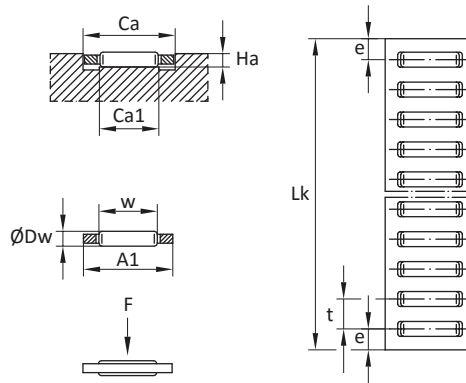

Abmessungen Dimensions (mm)

Tragzahlen load capacity

Konstruktions - Abmessungen Functional dimensions

Gewicht weight

Typ Type	$\varnothing Dw$	A1	Dw	Lw	t	e	Lk max.	C N	C0 N	Ca +0,2	Ca1 min.	Ha	Gew g / Lk (1000mm)
R10	2	10	2	6,8	4,5	3,5	2 000	21 600	62 800	10,3	7	1,7	63
R15	2,5	15	2,5	9,8	5	3,5	2 000	35 800	103 800	15,3	10	2,2	120
R20	3	20	3	13,8	6	4,5	2 000	51 900	148 000	20,4	14	2,7	202
R25	3,5	25	3,5	17,8	7	5	2 000	68 200	190 000	25,4	18	3,2	294

Bestellbeispiel / Ordering designation

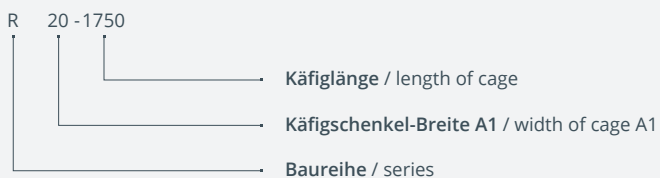

- Grundkörper besteht aus Leichtmetall - Aluminium (Standard)
Andere Materialien auf Anfrage
- Hohe Präzision und Festigkeit bei geringem Eigengewicht
- Geeignet für erschwerte Betriebsbedingungen sowie für hohe Betriebstemperatur bis 150°C
- Belastungen und Beschleunigungen
- Basis manufactured from light metal - aluminium (standard)
Other materials on request
- High precision and strength at light deadweight
- Assigned for hard working conditions, heavy loads and fast accelerations
- Working temperature up to 150°C

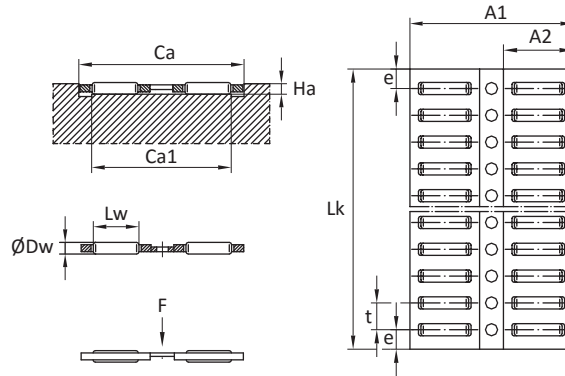

Abmessungen Dimensions (mm)

Tragzahlen load capacity

Konstruktions - Abmessungen Functional dimensions

Gewicht weight

Typ Type	ØDw	A1	A2	Dw	Lw	t	e	Lk max.	C N	C ₀ N	Ca +0,2	Ca1 min.	Ha	Gew g / Lk (1000mm)
R24 ZW	2	24	10,5	2	6,8	4,5	3,5	2 000	37 000	125 700	24,4	21	1,7	138
R34 ZW	2,5	33,5	14,3	2,5	9,8	5	4	2 000	57 000	188 800	34,0	28,5	2,2	239
R44 ZW	3	44	19	3	13,8	6	4,5	2 000	88 900	296 100	44,5	38	2,7	408

Bestellbeispiel / Ordering designation

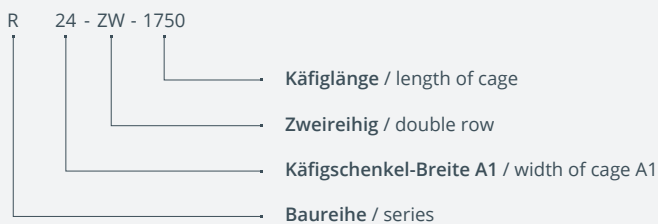

- Grundkörper besteht aus Leichtmetall - Aluminium (Standard)
Andere Materialien auf Anfrage
- Hohe Präzision und Festigkeit bei geringem Eigengewicht
- Geeignet für erschwerte Betriebsbedingungen sowie für hohe Betriebstemperatur bis 150°C
- Belastungen und Beschleunigungen
- Basis manufactured from light metal - aluminium (standard)
Other materials on request
- High precision and strength at light deadweight
- Assigned for hard working conditions, heavy loads and fast accelerations
- Working temperature up to 150°C

Nadelrollen-Winkelflachkäfige

Angular needle roller flat cages

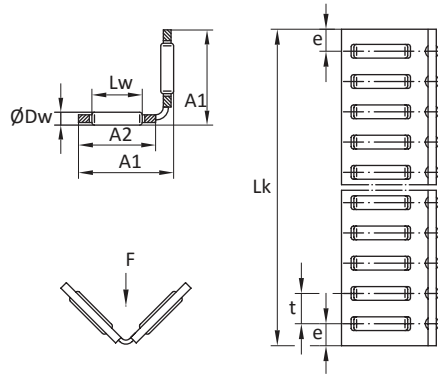

Abmessungen Dimensions (mm)

Tragzahlen load capacity

Gewicht weight

Typ Type	$\varnothing D_w$	A1	A2	Lw	t	e	Lk max.	C N	stat. C_0 N	Gew g / Lk (1000mm)
RW15	2	14	10,5	6,8	4,5	3,5	2 000	26 200	88 900	138
RW20	2,5	20	14,3	9,8	5	4	2 000	40 300	135 500	239
RW25	3	25	19	13,8	6	4,5	2 000	62 900	209 400	408
RW30	3,5	30	24	17,8	7	5	2 000	82 700	268 700	598

Bestellbeispiel / Ordering designation

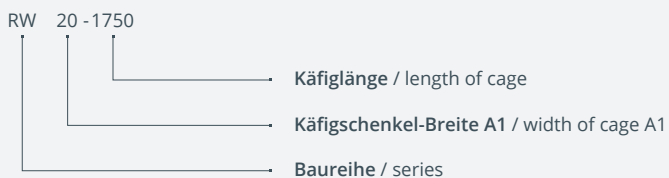

- Grundkörper besteht aus Leichtmetall - Aluminium (Standard)
Andere Materialien auf Anfrage
- Hohe Präzision und Festigkeit bei geringem Eigengewicht
- Geeignet für erschwerte Betriebsbedingungen sowie für hohe Betriebstemperatur bis 150°C
- Belastungen und Beschleunigungen
- Basis manufactured from light metal - aluminium (standard)
Other materials on request
- High precision and strength at light deadweight
- Assigned for hard working conditions, heavy loads and fast accelerations
- Working temperature up to 150°C

Weitere Produkte

Further products



**Profilschieneführungen /
Miniaturführungen**
Profile rail systems /
Miniature systems



Lineartische
Linear tables



Lineargehäuse-Einheiten
Linear housing units



Laufrollen
Track rollers



Module
Linear modules



Kugelgewindetriebe
Ball Screws

Laufrollenführung

Track roller guidance system



Tragschienen ELFS

Die Tragschienen ELFS sind in Verbundbauweise aufgebaut:

- Ein hochgenauer Aluminiumgrundkörper nimmt gehärtete und geschliffene Präzisionsstahlwellen auf, die als Laufbahnen für Laufrollen dienen.
- Das spezielle Einwalzverfahren sorgt für eine äußerst stabilen Verbund der Stahlwellen im Aluminiumgrundkörper.

Genauigkeit Tragschienen ELFS

Die angegebenen Parallelitäten sind mittels Differenzmessung ermittelt. Die Geradheitswerte der feingerichteten Tragschienen sind besser als DIN EN 12020.

Geradheitstoleranz / Straightness

L [mm]	t1 [mm]	t2 [mm]
L < 1000	0,5	0,2
1000 ≤ L < 2000	1	0,3
2000 ≤ L < 3000	1,5	0,4
3000 ≤ L < 4000	2	0,5
4000 ≤ L < 5000	2,5	0,6
5000 ≤ L < 6000	3	0,7

ELFS support rails

ELFS support rails are composite construction:

- An high-precision aluminum base element accommodates hardened and polished precision steel shafts that are used as tracks for track rollers.
- The special rolling-in process ensures the extremely robust bond of the steel shafts to the aluminum base element.

Accuracy of ELFS support rails

The parallelity values specified are determined using differential measurement. The straightness values of the finely aligned support rails are better than DIN EN 12020.



Bild / Fig. 1: Tragschiene ELFS / Support rails ELFS



Bild / Fig. 2: Genauigkeit / Accuracy

Bohrbild

Ohne gesonderte Angabe werden Tragschienen mit symmetrischem Bohrbild geliefert. Auf Wunsch ist auch ein unsymmetrisches Bohrbild möglich, dabei sind die Mindestabstände T1 und T2 zu beachten. Alle Tragschienen ELFS sind auch ohne Bohrungen verfügbar: Kennziffer OL.

Montage

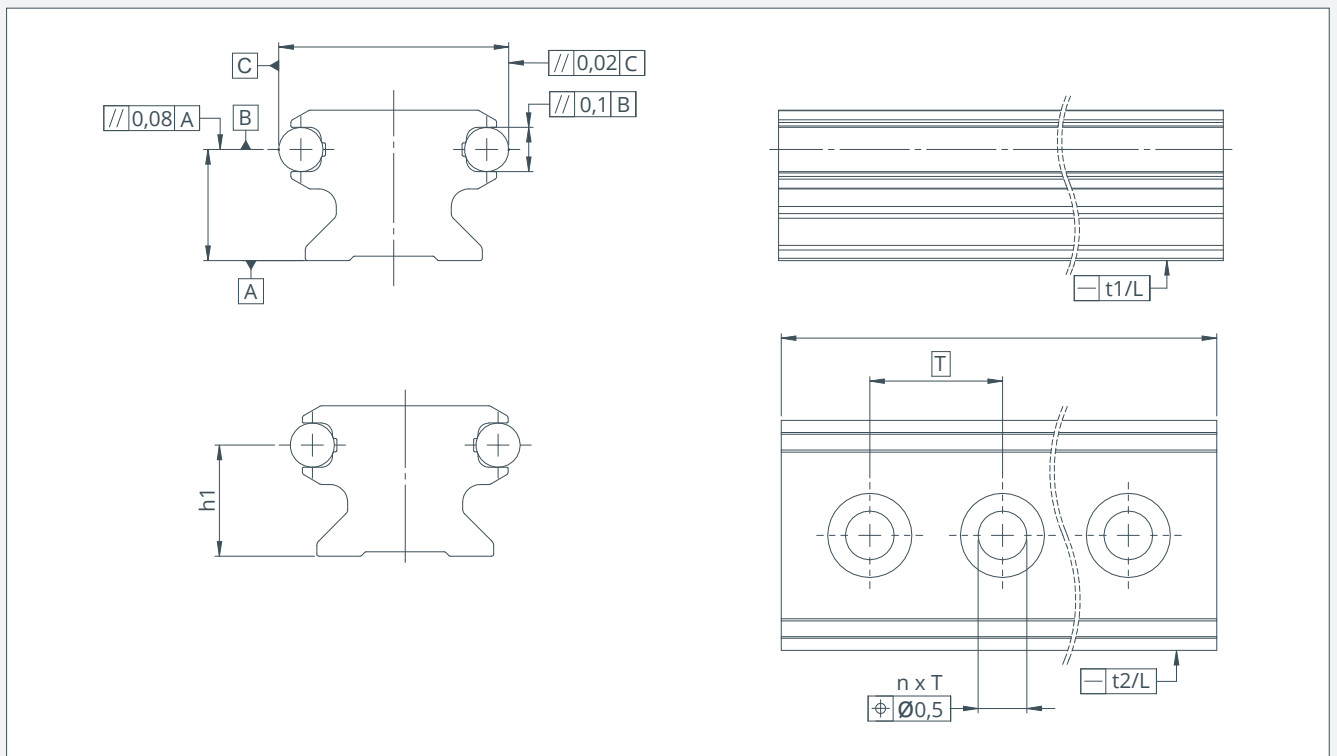
- Schrauben leicht anziehen
 - Tragschiene ausrichten
 - Schrauben mit Anziehdrehmoment festziehen
- Bei hohen Belastungen Unterlagscheiben nach DIN 433 verwenden. Wenn ohne seitlichen Anschlag montiert wird, zul. Seitenlasten beachten.

Besondere Anwendungsbedingungen

Unter bestimmten Anwendungsbedingungen wie Vibrationen, Wechsellasten unter hoher Beschleunigung in Verbindung mit zu weichen Anschlusskonstruktionen oder unvollständig unterstützte Tragschienen können die eingewalzten Stahlwellen eventuell um mehrere Millimeter im Aluminiumgrundkörper wandern. Je nach Erfordernis ist eine formschlüssige Axialsicherung sinnvoll.

Länge Tragschienen / Length of support rails

L [mm]	t3	
Einteilige Tragschienen / Single part support rails	L < 1000	±2 mm
	1000 ≤ L < 2000	±3 mm
	1000 ≤ L < 4000	±4 mm
	4000 ≤ L	±5 mm
Mehrteilige Tragschienen / Several part support rails	Gesamtlänge L / Total length L	±0,1 %

Anziehdrehmoment Schraube / Tightening torque

Schraube / Screw	Anziehdrehmoment / Tightening torque
ISO 4762-8.8	M _A
M5	5,8 Nm
M6	9,9 Nm
M8	24 Nm
M10	48 Nm

Hole pattern

If not otherwise stated, the support rails are supplied with a symmetrical hole pattern. An unsymmetrical hole pattern can also be provided upon request; in this case the minimum distances T1 and T2 must be observed. All ELFS support rails are also available without holes: code OL.

Installation

- Lightly tighten screws
 - Align support rails
 - Tighten screws with tightening torque
- For high loads, use washers that meet DIN 433 requirements. If installed with no side stop, comply with permissible side loads.

Special conditions for use

Under certain conditions of use, such as vibrations, alternating loads under high acceleration in combination with too soft connection structures, or incompletely supported support rails, the rolled-in steel shafts may drift by several millimeters in the aluminum base element. Where necessary, a positive self-locking axial support is recommended.

Max. Seitenlast / Max. lateral load

Größe / Size	Seitenkraft / Lateral force
ELFS	F _z (zul)
20	200 N
25	330 N
32 / 32E	450 / 900 N
52 / 52E / 52EE	1000 / 1600 / 4000 N



Bild / Fig. 3: Bohrbild / Hole pattern



Abmessungen
Dimensions (mm)

Gewicht
Weight

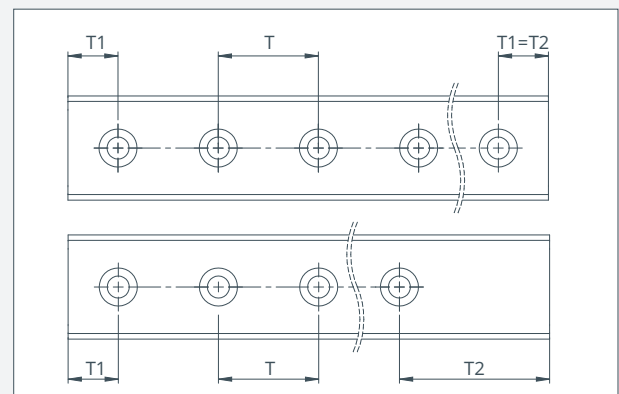
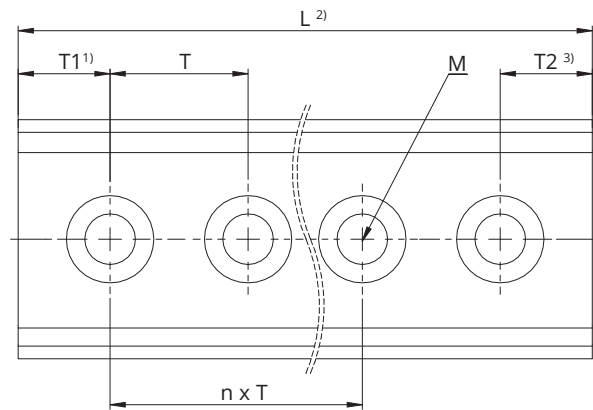
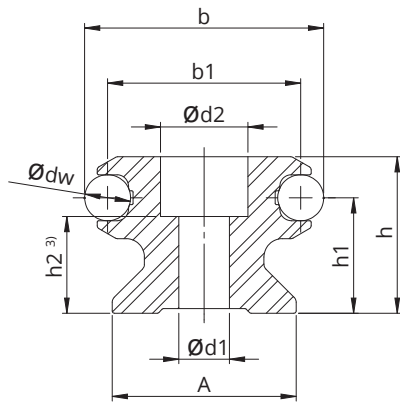
Typ Type	dw	b	A	h	b1	h1	h2 ³⁾	d1	d2	M	L ²⁾	T	TE	TEE	[kg/m]
ELFS20	4	20	17	12,2	16	9	7.6	4.5	8	M4	3000	62,5	-	-	0,79
ELFS25	6	25	21	15	19	10,6	8,5	5,5	10	M5	3000	62,5	-	-	1,10
ELFS32	6	32	24	20	26	15	12	6,5	12	M6	6000	125	-	-	1,56
ELFS32E	6	32	24	20	26	15	12	6,5	12	M6	6000	-	62,5	-	1,56
ELFS32F	6	32	-	10	26	5	3,5	6,5	12	M6	6000	125	-	-	1,10
ELFS52	10	52	40	34	42	25,1	21	11	19	M10	6000	250	-	-	4,33
ELFS52E	10	52	40	34	42	25,1	21	11	19	M10	6000	-	125	-	4,33
ELFS52EE	10	52	40	34	42	25,1	21	11	19	M10	6000	-	-	62,5	4,33
ELFS52F	10	52	-	18	42	9	8	11	19	M10	6000	250	-	-	3,05

- 1) T1 und T2 sind von der Schienenlänge abhängig. Allgemein gilt: T1 (min) / T2 (min) = 20 mm. Andere Werte nach Anfrage möglich
- 2) Maximale Länge der einteiligen Tragschiene, größere Längen werden mehrteilig geliefert
- 3) Senktiefe für Schrauben DIN912 - bei Verwendung von Unterlagscheiben DIN433 sollten Schrauben DIN7984 verwendet werden

- 1) T1 and T2 depend on the rail length. In general: T1 (min) / T2 (min) = 20 mm. Other values are possible on request
- 2) Maximum length of the single-part support rail; longer lengths are delivered in several parts
- 3) Countersink depth for DIN912 screws - for use with DIN433 washers, DIN7984 screws should be used

Bestellbeispiel / Ordering designation

ELFS 52E RB - 1500 - 50 / 75 Tragschiene / Support rail
 ↳ Bohrungsabstand T2 / Pitch distance T2
 ↳ Bohrungsabstand T1 / Pitch distance T1
 ↳ Schienenlänge L / Rail length L
 ↳ Korrosionsarm / stainless steel
 ↳ Größe / size
 ↳ Baureihe / series



Bild / Fig. 4: ELFS.. F



Abmessungen Dimensions (mm)

Gewicht Weight

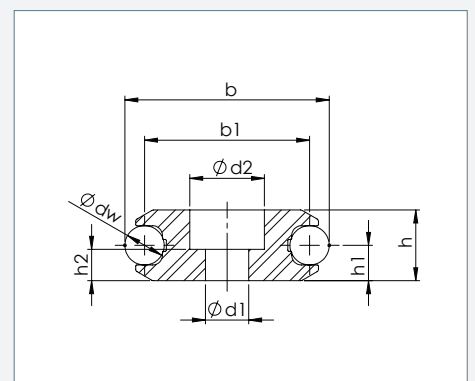
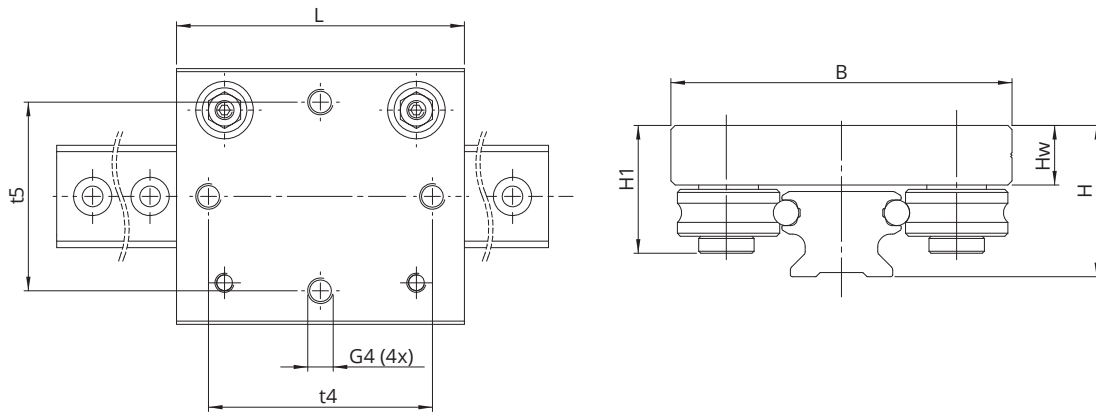
Typ Type	Laufrolle Track roller	L	B	H	H1	t4	t5	G4	Hw	[kg]
ELFL20	LFR50/5-4 KDD	50	55	22	20,5	38	40	M5	9	0,16
ELFL25	LFR50/5-6 KDD	75	64	25	21,9	60	50	M5	10,4	0,35
ELFL32	LFR50/8-6 KDD	90	80	35,5	30	70	59	M8	14	0,40
ELFL52	LFR5201-10 KDD	100	120	54,3	43,2	70	90	M10	19,5	1,00



Bild / Fig. 5: Lastrichtungen und Momente / Load directions and moments

Tragfähigkeit / Load capacity

	Tragzahlen / Load ratings [N]				Momente / Moments [Nm]		
	Cy	Coy	Cz	Coz	Mox	Moy	Moz
ELFL20	1330	845	2300	1620	7	22	11
ELFL25	1330	845	2300	1620	8	41	17
ELFL32	4210	2250	7100	4300	29	132	70
ELFL52	10000	5120	17000	10000	108	300	148

Profillaufrollen LFR

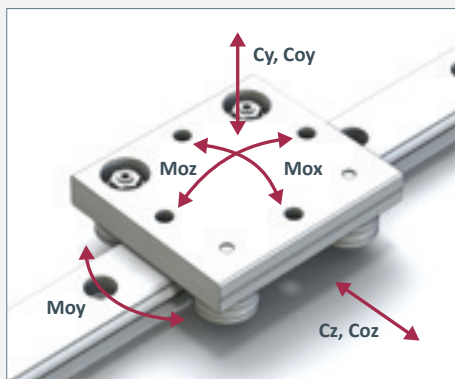
Auf der Basis von Tragschienen ELFS werden Profillaufrollen LFR kombiniert um aus allen Richtungen belastbare Linearführungen zu konzipieren.

- LFR sind von in ihrem Aufbau her mit zweireihigen Schrägkugellagern ohne Füllnut zu vergleichen. Die Profillaufrolle ist komplett aus Wälzlagerstahl 100Cr6 hergestellt
- Neben Radiallasten können auch in beiden Richtungen Axiallasten aufgenommen werden
- Der extra verstärkte Außenring lässt hohe Radiallasten zu
- Das Laufprofil des Außenringes ist als gotischer Bogen profiliert und steht im Zweipunktkontakt auf der Wellenlaufbahn
- Genauigkeitsklasse PN DIN620
- Radiale Lagerluft annähernd Klasse CN

Zapfen LFZ und LFE

Zur Anbindung der Profillaufrollen LFR an einen Schlitten oder Tisch werden Zapfen zum Einschrauben benötigt.

- Neben dem zentrischen Zapfen LFZ dient der exzentrische Zapfen LFE zur spielfreien Einstellung der Linearführung
- Die Zapfen bestehen aus hochwertigem Vergütungsstahl
- Die im Lieferumfang enthaltenen Scheiben dienen zur Freistellung der verschraubten Profillaufrolle

Empfohlener Laufrollenabstand

Bei Verwendung der Tragschienen ELFS sind die Bohrungen für die Profillaufrollen im Abstand nach Tabelle auszuführen.

Laufrollenabstand / Track roller spacing

Größe / Size	Abmessungen / Dimensions [mm]
ELFS	E ($\pm 0,2$)
20	34
25	40
32	54
52	83,3



Bild / Fig. 6: Laufrolle LFR / Track roller LFR



Bild / Fig. 7: Zapfen / Bolt

LFR profiled track rollers

Based on ELFS support rails, LFR profiled track rollers are combined in order to design linear guides that can be loaded from all directions.

- LFR can be compared in their structure with double-row angular contact ball bearings without filling slots. The profiled track roller is entirely made of 100Cr6 roller bearing steel.
- In addition to radial loads, axial loads are supported in both directions.
- The extra reinforced outer ring permits high radial loads.
- The running profile of the outer ring has a Gothic arch profile and is in two-point contact with the shaft track.
- Accuracy class PN DIN620
- Radial bearing clearance approaching class CN

LFZ and LFE bolts

Bolts are needed for screwing in to connect LFR profiled track rollers to a carriage or table.

- In addition to the LFZ centric bolts, the LFE eccentric bolts is used for clearance-free adjustment of the linear guide
- The bolts are made of high-quality heat-treated steel.
- The washers included in the scope of supply are used for the release of the screwed on profiled track roller.

Recommended track roller spacing

When using ELFS support rails, the holes for the profiled track rollers must be drilled using the distances given in the table.



Bild / Fig. 8: Empfohlener Laufrollenabstand / Track roller spacing



Bild / Fig. 9: Laufrolle LFR-KDD und Zapfen LFE/LFZ / Track roller LFR-KDD and bolt LFE/LFZ

Maße Laufrolle LFR...-KDD / Dimensions track roller LFR...-KDD

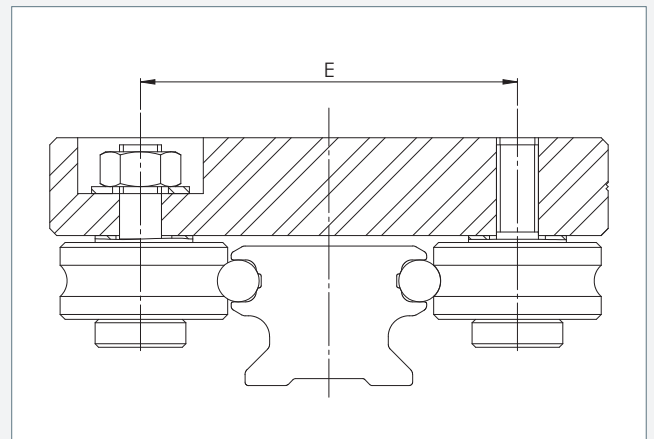
...-KDD	Abmessungen / Dimensions [mm]							Tragzahlen / Load ratings [N]				Empfohlene Zapfen / Suggested bolts	
	dw	d	D	C	B	A	r	Cw	Cow	Frz	Forz		
LFR50/5-4	4	5	16	7	8	9	0,2	1200	860	1300	1780	LFZ5 / LFE5	
LFR50/5-6	6	5	17	7	8	10,5	0,2	1270	820	1300	1780	LFZ5 / LFE5	
LFR50/8-6	6	8	24	11	11	14	0,3	3670	2280	1300	4560	LFZ8 / LFE8	
LFR5201-10	10	12	35	15,9	15,9	20,65	0,6	8500	5100	5100	10200	LFZ12 / LFE12	
LFR5301-10	10	12	42	19	19	24	0,6	13000	7200	7500	14200	LFZ12M12 / LFE12M12	

Maße Zentrischer / exzentrischer Zapfen / Dimensions centric / excentric bolt

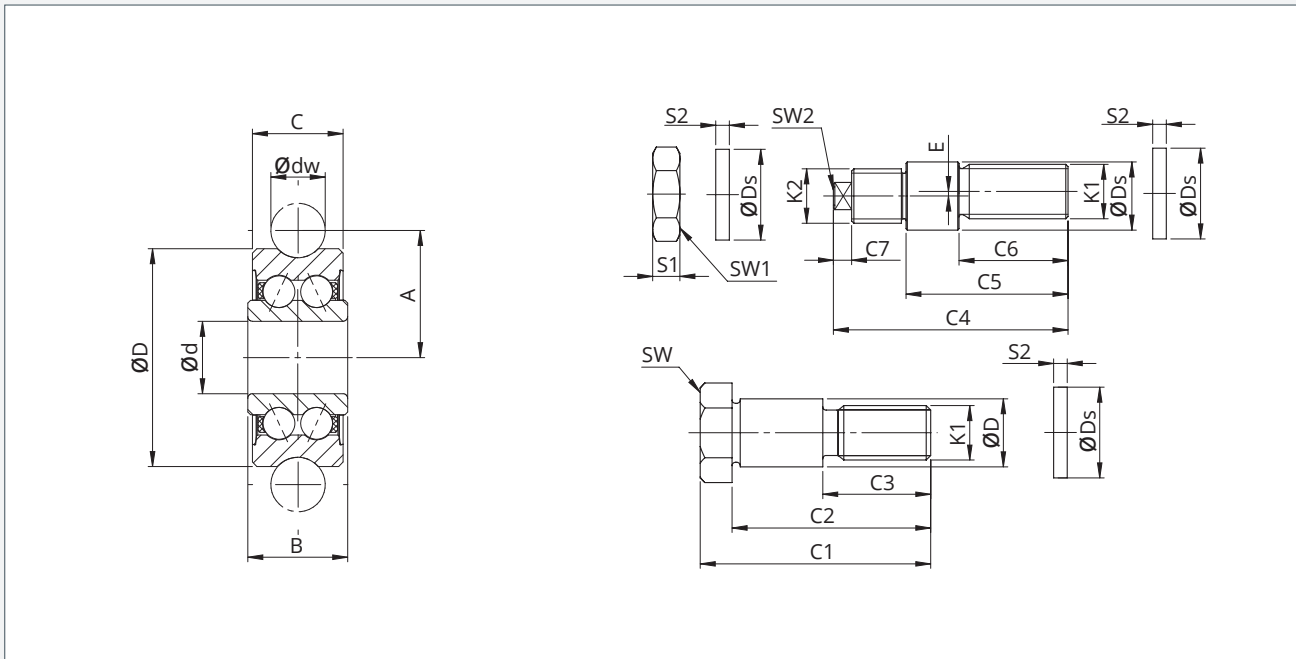
	Abmessungen / Dimensions [mm]															
	d	K1	K2	C1	C2	C6	C4	C5	C7	Ds	E	S1	S2	SW	SW1	SW2
LFZ5	5	M4	-	19,5	16	9,5	-	-	-	-	-	-	-	3	-	-
LFE5	5	M4	M4	-	-	9	20,5	15	-	-	0,5	2,9	-	-	7	2
LFZ8	8	M8	-	28,3	24,3	15	-	-	-	14	-	-	1	12	-	-
LFE8	8	M8	M8	-	-	13,7	33,2	22	3,5	14	1	4	1	-	13	5
LFZ12	12	M10	-	43	36	22	-	-	-	21	-	-	1,8	17	-	-
LFE12	12	M10	M10	-	-	19,5	50	33,5	5	21	1	8,4	1,8	-	17	6
LFZ12-M12	12	M10	-	50,8	43,8	24	-	-	-	19	-	-	1,8	17	-	-
LFE12-M12	12	M10	M12	-	-	24	57	41	5	19	1	6,5	1,5	-	17	6

Zertifikate Certificates



EXXELLIN 

EXCELLENCE IN LINEAR MOTION



EXXELLIN GmbH
Rogätzer Straße 34 / 39326 Wolmirstedt



tel. +49 39201 700500



fax +49 39201 700501



e-mail vertrieb@exxellin.com (Deutschland)
sales@exxellin.com (other countries)



web www.exxellin.com