

Green Gear Trasmissioni S.r.l.

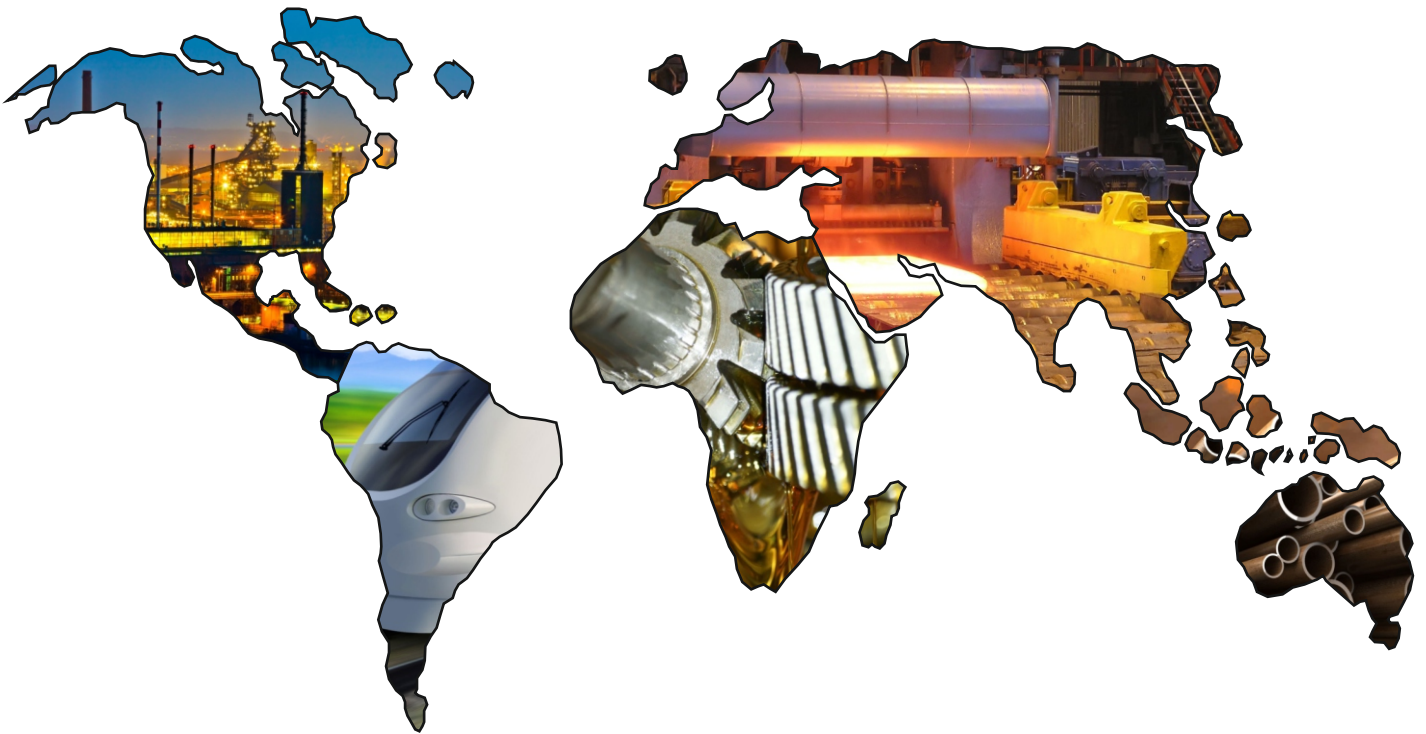

CATALOGUE - BGC 2013 EDITION

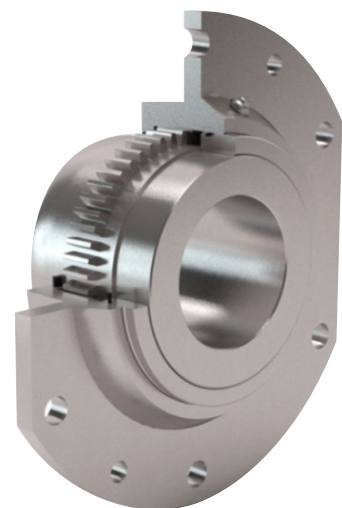

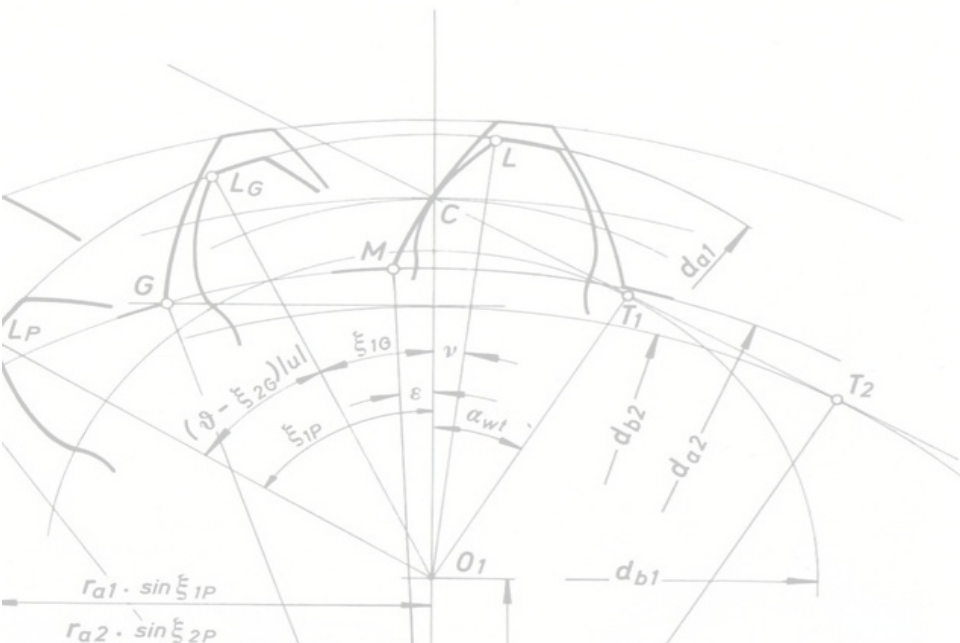
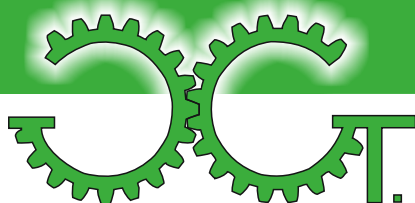

GGT GEAR COUPLINGS FOR CRANES – BGC SERIES

FEATURES & COMPOSITION

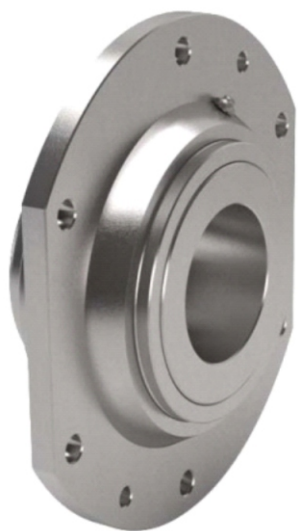

GGT drum couplings, BGC series, are composed of:

- One semicircular gear sleeve;
- One gear hub with developed toothing;
- Special seals to ensure the perfect tightness of the inner part, preventing inlet of dust and outlet of grease;
- Special inner cover;
- Grease nipple;

BGC SERIES ADVANTAGES

- 1) DEVELOPED DESIGN**
- 2) STRONGER INDIVIDUAL TOOTH**
- 3) LONGER LIFETIME**
- 4) HIGHER LOAD CAPACITY**
- 5) HIGHER TRANSMITTABLE TORQUE**
- 6) FULL RANGE OF SIZES**

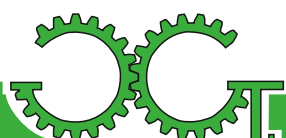

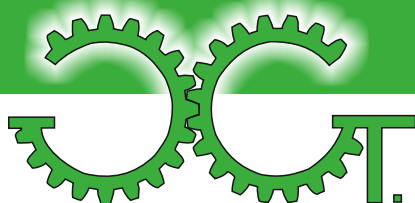

GGT GEAR COUPLINGS FOR CRANES – BGC SERIES

APPLICATION

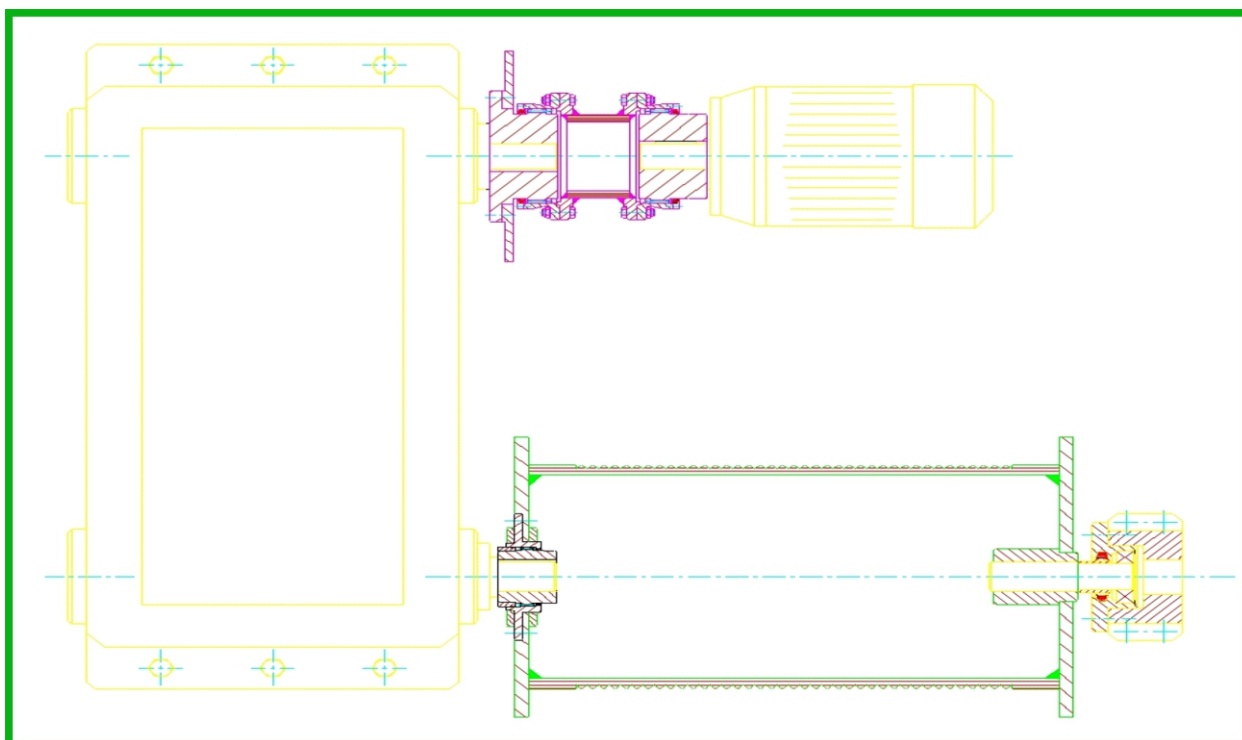

Lay-out of a single drum drive with a drum gear coupling

GGT drum gear couplings are typically suitable for installation in lifting mechanisms and drum drives of cranes, to connect the cable drum with the gearbox output shaft, as well as in winch conveyors and platform hoists.

GGT drum gear couplings, installed between the gearbox and cable drum, perform the function of an articulated joint, in order to make the connection statically determinate and avoiding the occurrence of high bending moments.

From the design point of view, we can grant longer lifetime, due to our developed gear toothing, in combination with our special lubricant, which distinguishes itself from the others in terms of the oil base, essentially.

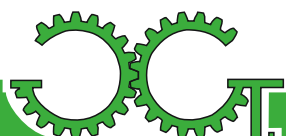
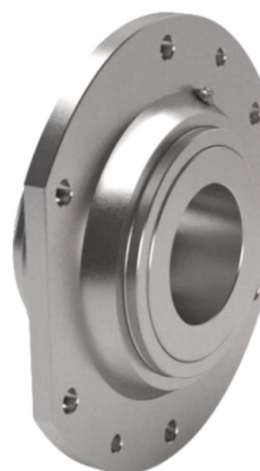

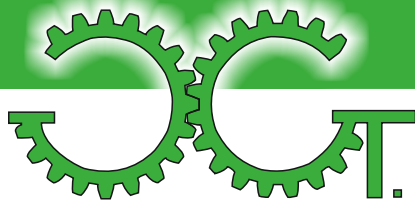

GGT GEAR COUPLINGS FOR CRANES – BGC SERIES

DIMENSIONS & PARAMETERS

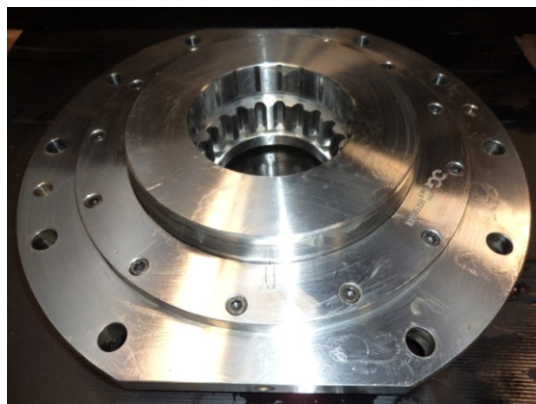
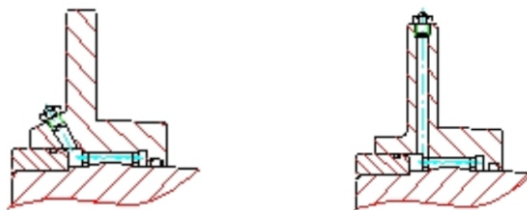
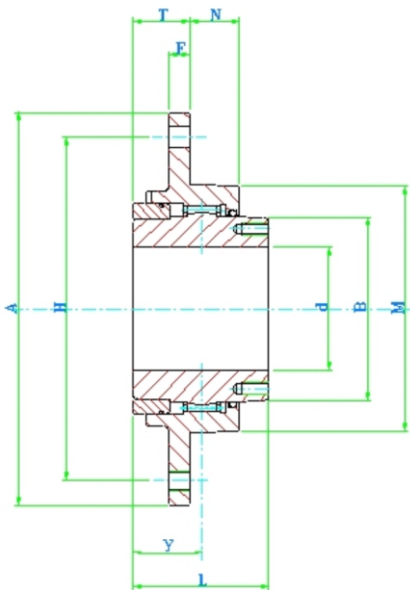

SIZE	Nominal Torque Tk [kNm]	Max Torque Tf [kNm]	Max Load Qp [kg.]	Max Bore d [mm]	A	H	M	B	L	Z	Weight
BGC280	22,2	33,3	3600	100	320	280	200	149	110	6	28
BGC300	27,5	41,3	4050	110	340	300	220	165	125	6	36
BGC320	34,1	51,2	4500	120	360	320	240	184	130	6	44
BGC340	46,2	69,3	5500	130	380	340	260	196	145	6	53
BGC360	61	92	6750	150	400	360	280	222	170	6	73
BGC380	83	125	8300	165	420	380	310	253	175	6	96
BGC400	97	146	11300	175	450	400	340	266	185	6	120
BGC460	146	219	14600	210	510	460	400	317	220	6	158
BGC500	168	252	16000	220	550	500	420	330	240	6	223
BGC530	205	443	18200	245	580	530	450	368	260	8	284
BGC600	352	528	22500	290	650	600	530	435	315	8	466
BGC630	380	570	25400	305	680	630	560	460	350	24	574
BGC670	475	713	29400	330	710	670	600	500	380	24	718
BGC730	593	890	35800	375	780	730	670	560	410	24	956
BGC800	708	1062	42000	410	850	800	730	610	450	24	1230

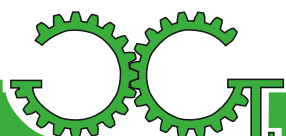

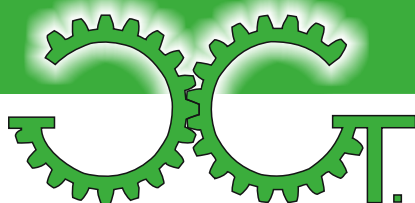

GGT GEAR COUPLINGS FOR CRANES – BGC SERIES

FLANGE DRILLING

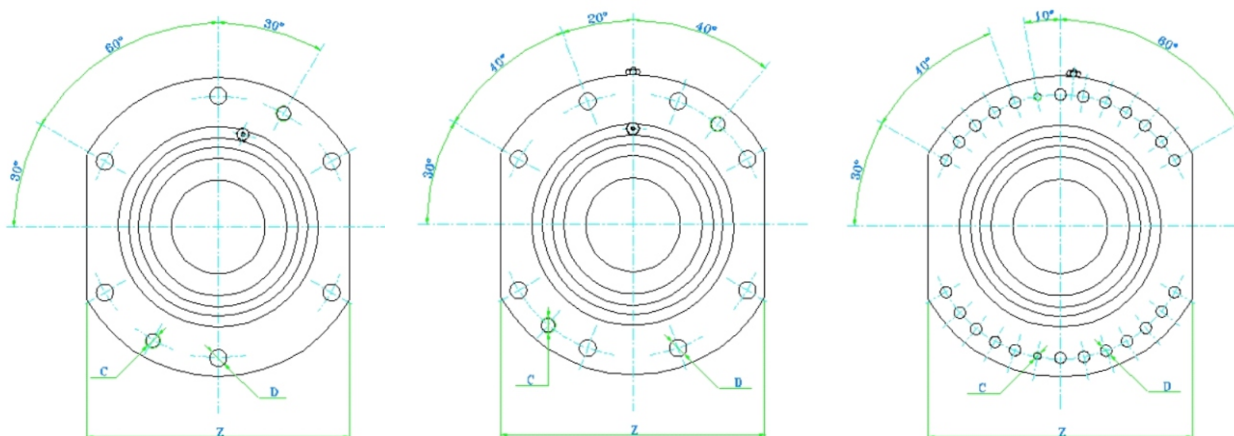

Z number of holes

DIMENSIONING

PARAMETERS	To check the following conditions:
$T \text{ [kNm]} = (P \times 9,55)/n$	$T_k = T \times K$
P [Kw] motor power - n [rpm] speed	T [kNm] = max torque on the drum
K = Service Factor	$T_k \text{ [kNm]} = \text{nominal torque of the coupling}$
Q [kg] = max radial load	max radial load of the coupling $Q_p = Q$
D [mm] = shaft diameter	max bore diameter of the coupling $d = D$

SERVICE FACTOR FOR HOISTING DEVICE

CLASS acc. to UNI 7670	1 mC	1 mB	1 mA	2 m	3 m	4 m	5 m	5 m
Max Period of Use [h]	400	800	1600	3200	6300	12500	25000	50000
Service Factor K	1,00	1,12	1,25	1,40	1,60	1,80	2,00	2,50

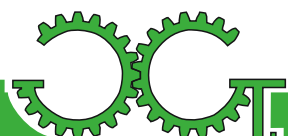

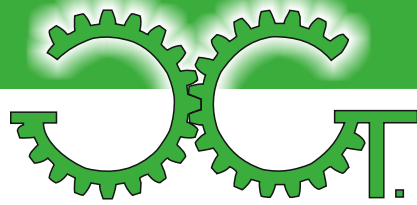

Green Gear Trasmissioni S.r.l.

Stabilimento ed Uffici

Strada provinciale N.38 Asti-Casorzo
14030 Scurzolengo (AT) ITALY

Tel. +39 0141 203522
Tel. +39 0141 1850506
Fax +39 0141 1850491
Cell. +39 338 2013358

info@greengeartrasmissioni.com
www.ggtsrl.biz

